

# An Introduction to Programmable Attenuator Systems

Sponsored by: JFW Industries



Figure 1: A selection of programmable attenuators ranging from a single unit (left) to a limited-fan-out 24-port transceiver test system (right). Source: JFW Industries

An attenuator is an electrical component that reduces the amplitude of a signal passing through it without significantly degrading the integrity of that signal. In a programmable or step attenuator, the attenuation is controlled externally by an external analog or digital signal, either manually or via a computer. Depending on the model, the maximum attenuation ranges from 0 dB to 127 dB, in steps as small as 0.1 dB. The attenuator is controlled by a combination of digital inputs, an analog voltage or via USB, RS-232, Ethernet or GPIB. These devices are bi-directional, so either port can act as an input or an output.

JFW produces many programmable attenuators and attenuator systems for different applications. This article will review the key components of a programmable attenuator system and discuss the best choices for some common applications. Figure 1 shows several JFW programmable attenuators.

## Applications for Programmable Attenuator Systems

Programmable attenuators test and evaluate the performance of many wireless applications:

- Military radios
- First responder networks
- Wi-Fi/MU-MIMO
- Cellular networks
- Mesh networks (ZigBee, LoRa, etc.)
- Emerging IoT/5G systems

## Key Specifications

The key specifications of a programmable attenuator include:

- the frequency range
- the VSWR (voltage standing wave ratio), a measure of how efficiently RF power is transmitted through the attenuator
- the attenuation range and step size
- the characteristic impedance (usually 50 or 75  $\Omega$ )

Combining multiple attenuators into a single unit gives a more compact design and saves cost.

Sponsored by:



Produced by:



- the maximum RF input power
- the insertion loss—the loss of signal power from the addition of the attenuator into the RF path

Figure 2 shows the specification sheet for the Model 50PA-860, a programmable attenuator system with 48 parallel channels.

SPECIFICATION SHEET		JFW Industries, Inc.	
JFW MODEL 50PA-860		Phone: 317-887-1340	
PROGRAMMABLE ATTENUATOR ASSEMBLY		sales@jfwindustries.com	
		www.jfwindustries.com	
Frequency Range	200-6000 MHz		
Configuration	48 individually controlled solid-state programmable attenuators		
Enclosure Type	19 inch rack mount @ 4RU high		
Impedance	50 Ohms nominal		
Attenuation Range	0-63 dB in 1 dB steps		
Startup/Default States (configurable)	Maximum attenuation (see ATTEN STARTUP command) DHCP enabled (see NET command) 4 Ethernet users (see NET USERS command) Prompts off (see PROMPT command)		
VSWR	1.8:1 maximum	200-800 MHz	
	1.6:1 maximum	800-6000 MHz	
Attenuation Accuracy (guaranteed monotonic)	± 0.50 dB	1-3 dB	
	± 0.75 dB	4-7 dB	
	± 1.00 dB	8-11 dB	
	± 1.25 dB or 4%	12-63 dB	
	(whichever is greater)		
Insertion Loss	6 dB maximum		
RF Input Power	+20 dBm average		
	+25 dBm (no damage)		
Switching Speed	1 microsecond typical (after command is received & processed) (3 milliseconds typical processing time)		

Figure 2: The key specifications of a programmable attenuator. Source: [JFW Industries](http://www.jfwindustries.com)

### Programmable Attenuator System Architecture

Combining multiple attenuators into a single unit gives a more compact design and saves cost. A programmable attenuator system contains one or more attenuators; the system power supply; a front interface panel; the internal control board; and a communications block for RS-232, Ethernet or other standards.

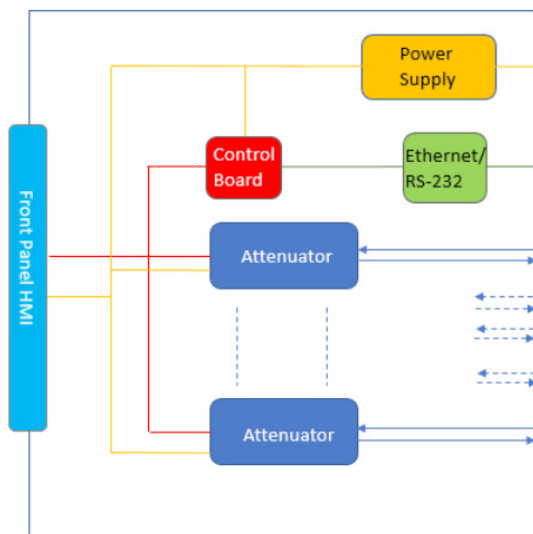

Figure 3: The parallel architecture has separate RF paths, but bundles common functions to reduce size and cost.

Figure 3 shows an example of a parallel test system architecture. Each attenuator has an independent input and output with no RF connection between attenuators. The parallel architecture is the simplest configuration. It's typically used to test multiple independent receivers and transmitters simultaneously in a production environment. JFW Industries offers 50 Ω and 75 Ω units in benchtop or 19 in. rack-mount configurations.

### Programmable Attenuator System Architecture

If we want to expand the capability of the simple parallel architecture, adding a power divider/combiner stage is a good first step. A power divider/combiner is a key component that distributes RF signals between multiple ports.

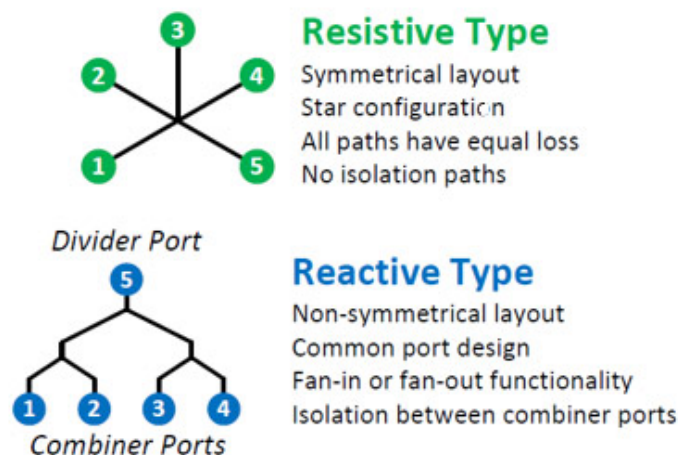

Figure 4: A comparison between resistive and reactive power dividers. Source: [JFW Industries](http://www.jfwindustries.com)

There are two main types of power divider/combiners:

- A resistive type operates as a hub to connect multiple Tx/Rx devices together in a symmetrical layout with no isolation between them. For example, a signal input at port 2 divides equally between ports 1, 3, 4 and 5. Each path has equal loss.
- A reactive type is non-symmetrical and distributes signals between multiple devices and a single device (fan-out and fan-in). In the configuration shown in Figure 4, port 5 is a divider port: an input at port 5 is routed equally to combiner ports 1-4 with equal loss. Conversely, input signals into ports 1-4 are combined equally and routed to port 5. However, ports 1-4 have at least 20 dB isolation between them.

There are significant differences in size and functionality between the two technologies: for example, a resistive power divider/combiner has twice the path loss of a reactive model. JFW Industries manufactures two types of reactive power divider/combiners suited to different applications. Consult this [application note](#) for more details.

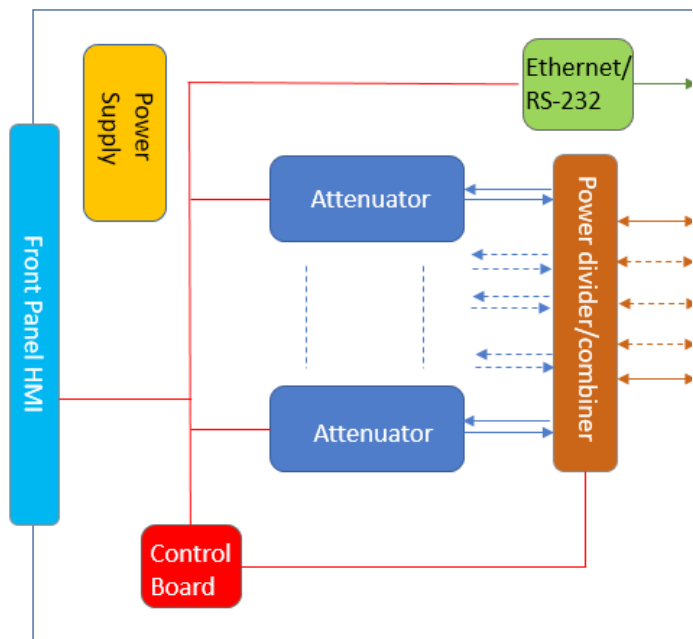

Figure 5: Adding a power divider/combiner block allows the system to combine ports to test complex RF networks with multiple transmitters and receivers.

### Handover Test Systems for Cellular-type Networks

A parallel architecture is well-suited for testing individual devices, but a wireless or Wi-Fi network requires a more sophisticated solution.

A typical cellular network consists of a small number of base stations that send fixed-power transmissions, typically less than 100 W, out to a larger number of mobile devices such as handsets, laptops or tablets. The mobile device reports back the signal strength of each base station it receives and automatically transmits at the lowest power needed to maintain good communication. As the mobile device moves around, and base station signal strengths vary, the network automatically transfers the device from one base station to another with higher power density when required.

A Wi-Fi network uses a similar configuration: it must transfer the Wi-Fi connection when a device moves between one wireless access point (WAP) and the next.

A handover system uses attenuators and power dividers to simulate this type of network: an input represents a base station antenna or access point, and an output represents a handset or other mobile device. A typical laboratory architecture may contain three or four base stations on the input side and the devices under test on the output side of the box. Any base station can connect to any or all of the handsets (devices). Strictly speaking, the terms input and output are used for convenience, as all of the paths are bi-directional.

A handover test system (Figure 6) provides connections for multiple network access points and multiple handsets. The full fan-out version has a step attenuator on every path with a power divider/combiner on either side, so that every RF path

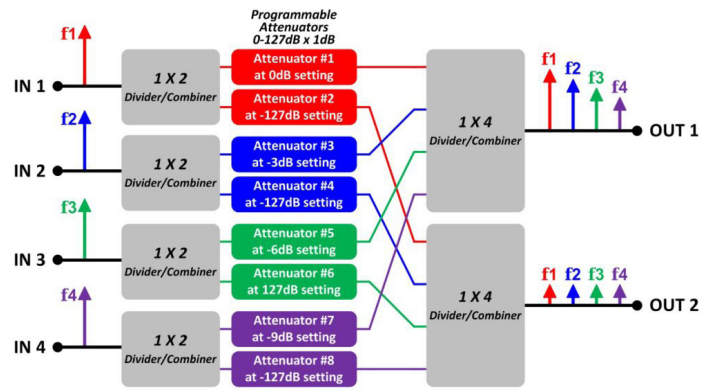

Figure 6: A handover test system. Source: JFW Industries

can have its own unique attenuation setting. Each output port in Figure 6 combines inputs f1, f2, f3 and f4, representing four base stations. The different attenuator settings on each input simulate different network conditions.

### Transceiver Test System (Mesh Network)

Many networks don't conform to the cellular and Wi-Fi network model. A mesh network doesn't distinguish the base station or access point and a mobile device or handset. A military or first-responder radio network, for example, has no base station to relay signals between one mobile device and another. It contains multiple transceivers communicating directly in a peer-to-peer network. A mesh network such as ZigBee or LoRa uses transceivers (nodes) as relays to reduce power consumption and increase network range. To reach a distant node, it's only necessary to reach the closest node.

A similar approach is being proposed for the next generation of cellular communications. Information in a 5G system will be transferred from phone to phone, phone to machine or device to device before eventually making its way to a tower to be offloaded onto a backhaul or the internet.

A transceiver test system is the most complex type of configuration. It will accommodate the largest number of device combinations and can do most types of RF testing. For example, it can simulate the activity in a high-workload military battlefield where a large number of radios are moving around in multiple directions, communicating with each other directly.

The system in Figure 7 is an example of a four-port transceiver test system with a full fan-out architecture. Every port is connected to every other port, with a unique programmable attenuator in each path.

There are no designated inputs or outputs in this architecture. The loss between two ports is the loss from the divider/combiner at each port plus the loss from the programmable attenuator in the signal path. For example in Figure 7 below, for the port 1-port 3 path, attenuator #2 is used.

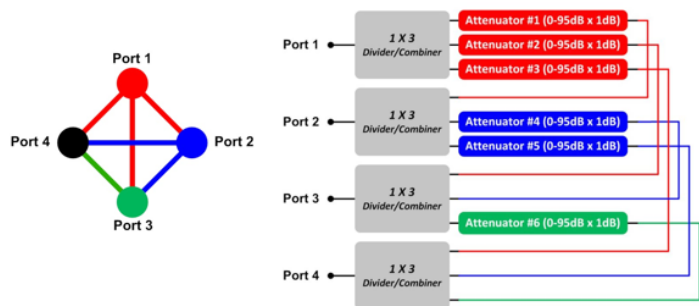

Figure 7: A transceiver test system. Source: JFW Industries

Each port can be connected to a device that can transmit and receive signals, like a radio or handset. The attenuators can be programmed to a different decibel setting for every path through the test system and the attenuator settings can vary over time to simulate signal fading between radios.

### Transceiver System Feature Comparison

Figure 8 shows the general configuration of the full fan-out system, plus two other alternative configurations that are designed for cost-sensitive applications.

Figure 8: A comparison of interconnections for three types of

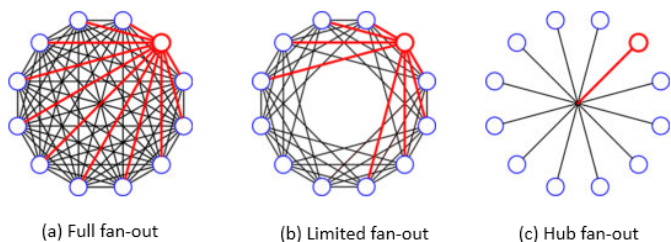

transceiver test systems. Source: JFW Industries

1. A [full fan-out transceiver test system](#) contains a fully populated connection matrix. As discussed, there is a path between every pair of ports and each path has its own individually controlled programmable attenuator. The number of programmable attenuators increases with the number of ports: adding the  $n$ th port increases the number of attenuators by  $(n-1)$ .

JFW manufactures full fan-out transceiver test systems with up to 32 ports; that design has 496 programmable attenuators.

2. b) A [limited fan-out transceiver](#) reduces size and cost by connecting each port to a limited number of

its neighboring ports. The number of connected ports can vary depending on the application: the 12-port LC8 design shown in Figure 8(b) above connects each port to its eight closest neighboring ports (four upper neighboring ports and four lower neighboring ports). This design requires only 48 programmable attenuators, compared to 66 attenuators if it were a full fan-out design.

The limited fan-out design is most useful for reducing the size and cost of designs with a large number of ports. Having more ports equates to testing a greater number of radios simultaneously. Changing from a full fan-out to a limited fan-out LC8 design in a 32-port system would reduce the number of programmable attenuators from 496 to 128, a reduction of 74 percent.

3. c) A [hub fan-out transceiver](#) test system is the least costly design: it is a star matrix configuration, so the number of paths is equal to the number of ports and it has a programmable attenuator on each port. The example shown contains 12 programmable attenuators; a resistive power divider/combiner connects all the ports. This configuration is useful for radio-to-radio testing: a typical setup uses a single transmitter (the red port) feeding multiple receivers (blue ports) with individual programmable attenuator settings.

### Transceiver System Feature Comparison

With all of the options available, which programmable attenuator system is right for your application?

If you're testing a large number of units independently with no interaction between them, go with a parallel test system. If you're testing a network with a relatively small number of fixed units coordinating communications with a relatively large number of mobile devices, check out a handover test system. Examples of such networks include cellular (LTE, TDD, FDD, etc.) and Wi-Fi.

If you're testing a mesh network such as ZigBee, a radio network, or developing next-generation cellular of 5G systems, a transceiver testing system is a good starting place. Be sure to scale it to the application, though, so you don't specify a full fan-out system with a large number of ports when a limited fan-out or hub system might be all you need.

And, of course, JFW Industries is always willing to help customers find the right system or custom tailor any design to your application.

#### JFW INDUSTRIES

5134 Commerce Square Drive  
Indianapolis, IN 46237  
Tel: 317-887-1340  
<https://www.jfwindustries.com/product-category/test-systems/>

#### ENGINEERING 360 MEDIA SOLUTIONS

201 Fuller Road, Suite 202  
Albany, NY 12203-3621  
Tel: +1 518 880 0200

#### ABOUT JFW INDUSTRIES

JFW Industries is a world leader in the design and manufacturing of RF Attenuators and RF Switches. Our attenuators, terminations, switches, power dividers, complete RF test systems and matrix switches are used for OEM and laboratory applications in the Wireless, Public Safety, Aerospace and Defense industries. Visit our website at [www.jfwindustries.com](http://www.jfwindustries.com) to see the thousands of existing, off-the-shelf models that are available or to learn more about our unique custom capabilities. JFW specializes in customizing any of our RF components or test systems for specific applications with no NRE charges (No Non-Recurring Engineering Fees!). There are no obligations to receive a quote. So, send us your specifications today.