

Methods

Mouser's technology & solutions ezine

Volume 1, Issue 3

**Best of 2017
Technical Content**



In This Issue

4

Welcome and Foreword

Deborah S. Ray

6

Best of Mouser Authors

Majeed Ahmad, Sylvie Barrak, Peter Brown, Steve Evanczuk, Paul Golata, Steven Keeping, Barry Manz, Michael Parks, Paul Pickering, Bill Schweber

7

Best of Technical Articles

8 Power Management: Heat Challenges Solved, *by Bill Schweber for Mouser Electronics*

14 Drones Ascend to New Heights: Bringing Unique Perspective to Broadening Markets, *by Michael Parks, PE, for Mouser Electronics*

18 New PV Cells Benefit Energy Harvesting, *by Steven Keeping for Mouser Electronics*

26 The Future of Healthcare May Reside in Your Smart Clothes, *by Peter Brown, Mouser Electronics*

32 Digital Twins Offer Unmatched Insights for Design Engineers, *by Michael Parks, PE, for Mouser Electronics*

35

Best of Webinars

Data Security: Think Like a Hacker *in partnership with Anitian Corporation*

36

Best of EIT

38 Augmented Reality: Beyond Gaming to Real-World Solutions, *by Peter Brown for Mouser Electronics*

44 My Way on the Highway; Life Inside Autonomous Vehicles: Beyond the Mobile Workplace, *by Sylvie Barak for Mouser Electronics*

49 Solar Roads Pave the Way for a Connected Infrastructure, *by Mouser Electronics*

50 Vertical Farms Thrive With Help from Technology, *by Paul Pickering for Mouser Electronics*

53 Conquering Vertigo: MEMs in Augmented Reality, *by Paul Golata, Mouser Electronics*

55

Best of Methods eZine

Understanding Bluetooth 5

56

Best of Projects

Smart Porch Light Project: Digi's XBee LTE Cellular Module, And Arduino Mega-2560 Shine Together, *by Joseph Downing, Mouser Electronics*

61

Best of Blogs

62 Your Microwave Oven May Soon Become Obsolete *by Barry Manz for Mouser Electronics*

64 Industrial Automation *by Marcel Consee, Mouser Electronics*

66 Piezoelectric Motor Provides Precise Motion Without Magnetics, Gears, *by Bill Schweber for Mouser Electronics*

68 Engineering Career Fairs: Yeah, You Gotta Talk About Yourself *by Deborah S. Ray, Mouser Electronics*

71 Enterprise Drives Augmented Reality Demand *by Steven Keeping for Mouser Electronics*



Mouser and Mouser Electronics are registered trademarks of Mouser Electronics, Inc. Other products, logos, and company names mentioned herein may be trademarks of their respective owners. Reference designs, conceptual illustrations, and other graphics included herein are for informational purposes only. Copyright © 2017 Mouser Electronics, Inc. – A TTI and Berkshire Hathaway company.

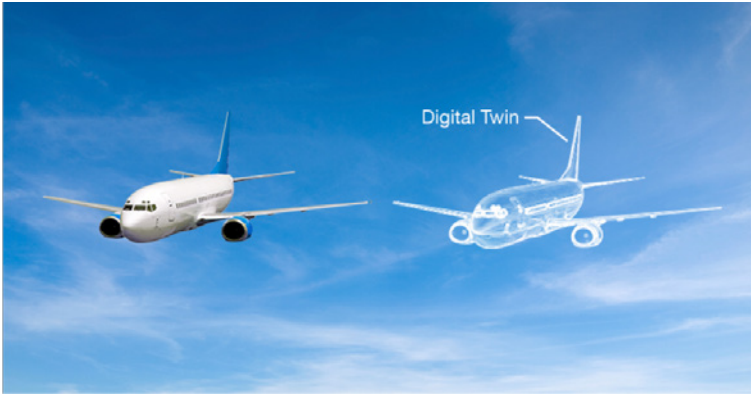

Executive Editor

Deborah S. Ray

Technical Contributors

JPaul Carpenter
Paul Golata
Rudy Ramos

Production

IEEE GlobalSpec

With Special Thanks

Kevin Hess
Sr. Vice President, Marketing

Russell Rasor
Vice President, Supplier
Marketing

Jack Johnston, Director
Marketing Communication

Raymond Yin, Director
Technical Content

Angelique O'Rourke
Media Manager



Welcome and Foreword

By Deborah S. Ray
With apologies to Clement Clarke Moore

'Twas the month before Christmas,
when all through the office
Not a person was stirring, not even our bosses.
Our schedules were hung by computers with care
In hopes that vacation soon would be there.

Our team was all nestled, so snug in our work
Ogling new products, too, well that didn't hurt.
With the boss in his cube and I at my desk
I thought my poor fingers finally could rest.

When out of nowhere there arose such a clatter
I lurched toward my keyboard to see what was the matter.
Toggling Windows, some browsers, and Flash
I found analytics and reports, with data to snatch.

The light from my monitor seemed all aglow
As my eyes scanned the data row by row.
The team now alerted, they later had said
A lightbulb was seen going on over my head!

I yelled 'cross the office to the boss (that'd be Raymond):
"You gotta come see this!" So he came and
More rapid than dial-up his coursers they came
As he whistled and shouted and called us by name:

"Now Ryan! Now Joseph! Now Rudy and Paul!
On, Deborah! On, JPau! Come down the hall!"
At the top of the hour, to the meeting we went
To discuss Mouser's best tech content.

As dry leaves like the wild hurricane fly
The ideas were many, the plan modified.
Then back to our desks the coursers, we flew
To get started with content we knew.

And then in a twinkling, I heard Raymond exclaim
The best of our content, the authors he named:
"There's Schweber and Parks and Barak and Brown!
And Keeping and Pickering and Manz," I've found.

He paused, as Evanczuk and Ahmad didn't rhyme
"I'll take care of it," I said, "It'll be fine!"

The topics—how they twinkled! The authors—so merry!
Their content was not only valuable, but very.

From autonomous vehicles to Bluetooth to drones...
Motors and power, "Wow! Our content has grown!"
Articles and blogs, ebooks and ezines
Webinars and projects—they're simply amazing!

Accurate and timely, Mouser's content stands true
Bringing key topics, top writers, and publications to you
So we spoke not a word and proceeded with glee
To put the best of the best in this collection, you see

From our team to your team, we've wanted a reason
To wish you merry moments this holiday season.
To celebrate the successes that you've engineered
And to tell you, "Stay tuned!" as we look toward next year.

Happy Holidays from Mouser's Technical Content Team:

Raymond Yin
EE, Director of Technical Content

Deborah S. Ray
Executive Editor and Technical Content Lead

Paul Golata
EE, Senior Technical Content Specialist

JPau Carpenter
EE, Technical Content and
Project Specialist

Joseph Downing
Technical Project Specialist

Rudy Ramos
Technical Review and
Special Projects Specialist

Ryan Snieder
Production Specialist

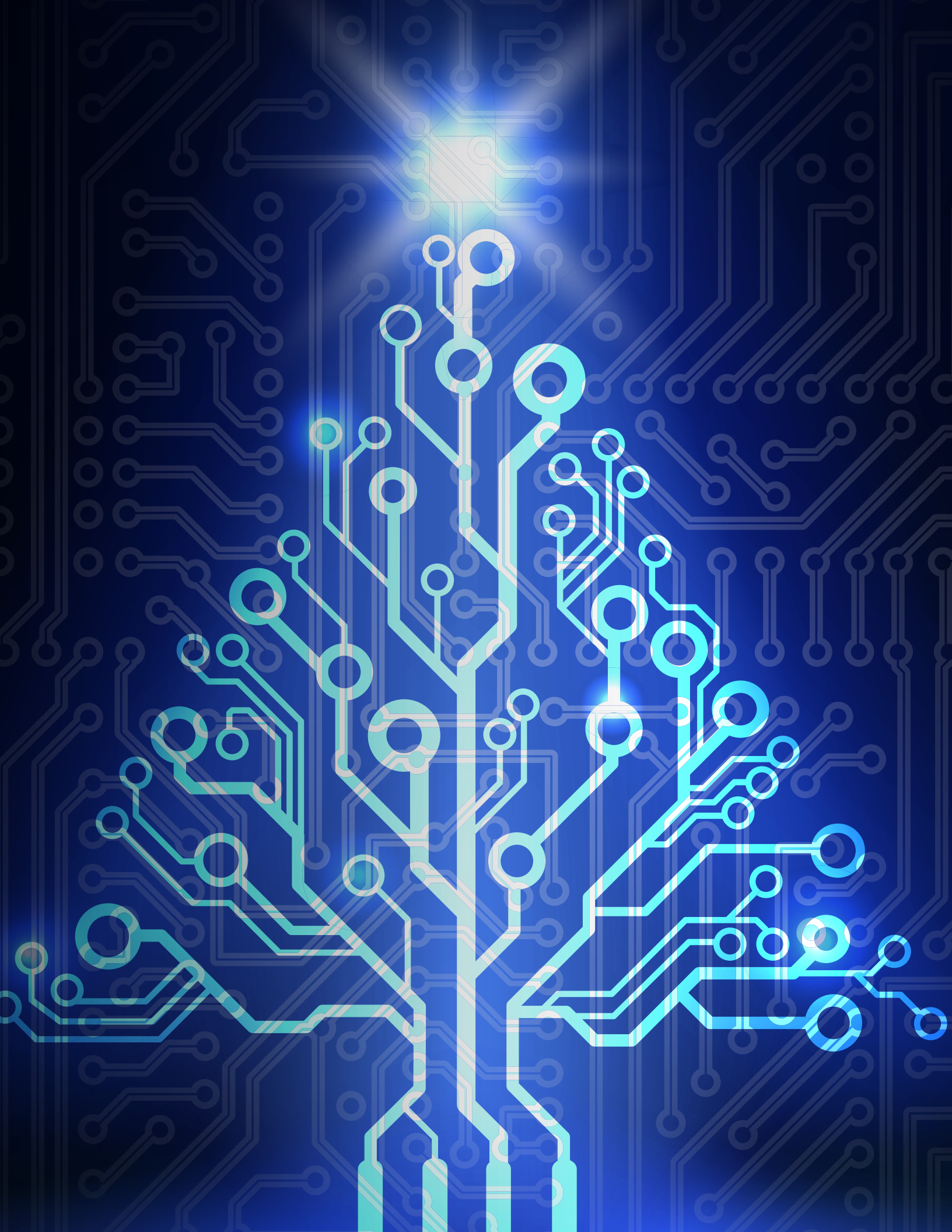

Best of Mouser Authors

Congratulations—and thanks to—Mouser’s top authors! We’re proud to publish technical content written by the electronics industry’s leading experts (and we had a hard time narrowing this list to just 10 authors!). The following authors were selected based on traffic to their content and the overall significance of their contributions to our publications. ●

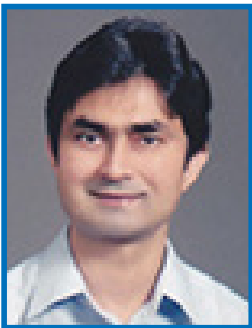

Majeed Ahmad

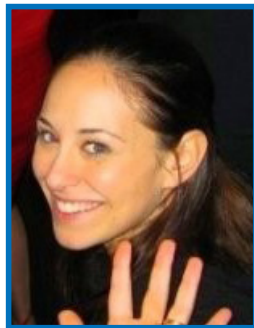

Sylvie Barrak

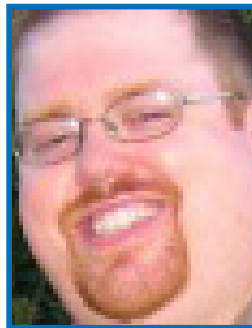

Peter Brown

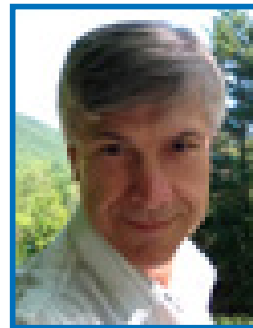

Steve Evanczuk



Paul Golata



Steven Keeping



Barry Manz



Michael Parks

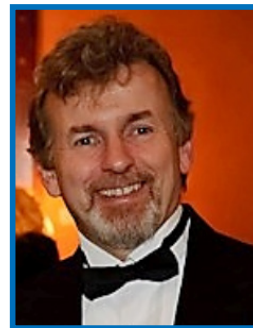

Paul Pickering



Bill Schweber

Best of Technical Newsletter Articles

Mouser's technical articles aim to help engineers solve design challenges and explore applications. We tackled a broad range of topics, including autonomous vehicles, motor control, power management, augmented reality, vertical farming, lighting, wearables and hearables, data security, harsh environments, open source hardware, RF wireless, communications, memory and storage, low-power, Industry 4.0, Internet of Things (IoT), Industrial IoT (IIoT), sensors, robotics, and much more!

Written by electrical engineers and other top experts, these articles are primarily delivered through our [technical newsletter](#), then reside on our [Applications and Technology site](#). ●



Power Management: Heat Challenges Solved

By Bill Schweber for Mouser Electronics

When electrical engineers use the phrase “power management,” most of us tend to think about the various DC power rails via assorted converters, regulators, and other power-handling and power-transforming functions. However, there is much more to power management than just those functions. All power sources give off heat due to inefficiency, and all components must dissipate some heat. Thus, power management is also concerned with thermal management, in particular how the dissipation of power-related functions affects the thermal design and heat buildup. Further, even if the component and system continue to function within specification, temperature increases induce changes in performance as component parameters drift. This may lead to eventual system malfunction if not outright failure. Heat also shortens component life and decreases mean time to failure, which makes it a long-term reliability consideration as well.

There are two thermal-management perspectives that designers must review:

- The “micro” view, where an individual component is in danger of overheating due to excess self-dissipation, but the rest of the system

(and its enclosure) are within acceptable bounds.

- The “macro” situations, where the entire system is too hot due to aggregate heat accumulation from many sources.

One design challenge is to determine how much of the thermal management problem is micro versus macro, and to what extent the two are related. Obviously, a hot component—even one that exceeds its allowed limits—will contribute to heating of the system, but that does not necessarily mean that the overall system will be too hot. It does, however, mean that the excessive heat of that one component must be managed and reduced.

One question to always keep in mind when discussing thermal management and using phrases such as “getting the heat out” or “removing the heat,” is this: To where is that heat being moved? A cynic might say the designer’s challenge is to find somewhere to dump that heat and thereby make his or her problem into someone else’s problem.

While that view is indeed somewhat cynical, there is an element of truth to it. The challenge is to get the heat to a cooler location where it will not have adverse effects on the system. This could be an adjacent

part of the system and enclosure, or it could be outside the enclosure altogether (possible only if it is cooler externally than internally). Also keep in mind one of the laws of thermodynamics: Heat will only travel from a higher-temperature location to a lower-temperature one, unless some sort of active pumping mechanism is used.

Thermal Management Solutions

Thermal management is governed by basic principles of physics. Heat transfer—here, in the cooling mode—occurs in a combination of three ways: Radiation, conduction, and convection (**Figure 1**):

- **Radiation** refers to heat that is carried away by electromagnetic radiation (mostly infrared) and can occur in a vacuum. In most applications, it is not a major cooling factor; an exception is in the vacuum of space, where it is the only way to draw heat away from the spacecraft.
- **Conduction** is the flow of heat through a solid or liquid, without actual movement of the heat-conveying material (although liquids do flow, of course).
- **Convection** is the flow of heat that is carried along by a fluid medium, such as air or water.

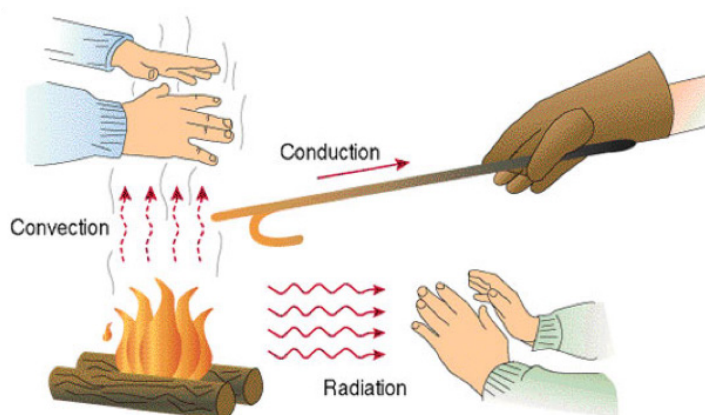

Figure 1: There are three mechanisms by which heat is transferred, and all are often involved in a given situation to differing extents. (Source: Kmechfiunit / CC BY-SA 4.0)

For most electronic systems, achieving the desired cooling is a combination of conduction away from the immediate source of the heat, and then convection to carry that heat elsewhere. The design challenge is to combine various pieces of thermal-management hardware—that is, hardware in the original, non-electronic sense of the word—to effectively implement the conduction and convection needed.

There are three elements which are most commonly used: Heat sinks, heat pipes, and fans. Heat sinks and heat pipes are types of passive, self-powered cooling, which also includes naturally-induced conduction and convection air flow methods. By

contrast, fans are a type of active, forced-air cooling.

Start with Heat Sinks

Heat sinks are aluminum or copper structures that draw heat from the source via conduction and expose it to air flow (and in some cases, to water or other liquid flow) for convection. They come in thousands of sizes and shapes, ranging from small, stamped metal wings which attach to a single transistor, **Figure 2**, to large extrusions with many fins (or fingers) which intercept the convection airflow and transfer the heat to that flow, **Figure 3**. One of the virtues of the heat sink is that it has no moving parts, no operating cost, and no failure

Figure 2



Figure 3

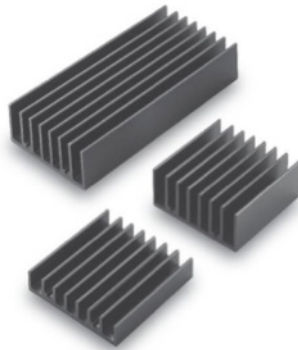

Figure 4



Figure 5



Figure 2: The simple sheet-metal [Aavid Thermalloy 574502B00000G](#) heat sink is designed to slide onto a TO-220 package transistor and features 21.2 C/W thermal resistance; it measures about 10 × 22 × 19mm. (Source: Aavid Thermalloy)

Figure 3: These larger, extruded multi-finned heat sinks ([M-C308](#), [M-C091](#), [M-C092](#)) from Cincom are designed for larger ICs as well as modules. The smallest is about 60 × 60 × 20mm high, while the largest one is 60 × 110 × 25mm high. (Source: Cincom Electronics)

Figure 4: This diminutive heat pipe from [Wakefield-Vette \(model 120231\)](#) measures just 6mm × 1.5mm diameter and is designed to convey heat loads up to 25W. (Source: Wakefield-Vette)

Figure 5: A tiny fan, such as the 30mm diameter × 6.5mm deep [ASB0305HP-00CP4](#) from [Delta Electronics](#), operates from a single +5V pulse width modulator (PWM) signal and can deliver about 0.144m³/min (5ft.³/min) of airflow. It is driven by a PWM signal and includes a tachometer feedback signal. (Source: Delta Electronics)

mode. Once the appropriate-sized heat sink is attached to the source, the convection occurs naturally as the warmed air rises, thus starting and continuing an airflow. Therefore, it is essential when employing a heat sink to allow for unimpeded air flow from source inlet to outlet. Also, the inlet must be below the heat sink and the outlet above; otherwise, the heated air will stagnate above the heat source and make the situation worse.

Despite the heat sink's ease of use, it does have some negative aspects. First, heat sinks that are sized to transfer large amounts of heat can get bulky, costly, and heavy. Also, they must be properly positioned, and thus can affect or constrain physical board layout. Their fins can get clogged with dirt and dust from the airflow, too, which greatly reduces effectiveness. They must be properly attached to the heat source so that the heat flows unimpeded from that source to the heat sink.

With so many heat sinks to choose from in terms of size, configuration, and other factors, making the choice can be overwhelming at first. Note that there are many general-purpose heat sinks, as well as those that are designed and sized for a particular IC, such as a specific processor or field-programmable gate array (FPGA) model.

There are also heat sink embodiments that are not discrete components. Some ICs use their pins or leads to conduct the heat away from their die and body to their PC board traces, which then function as heat sinks. Other ICs actually have a copper slug under their package; when it is soldered to the PC board, the slug acts as a pathway for removing heat from the die. This is a low-cost and effective way to conduct heat away, but it assumes that the rest of the PC board is cooler and that no other nearby components are also using the board for cooling. In effect, each device is trying to dump its excess waste heat into the neighbor's yard, which is a zero-sum game.

Add Heat Pipes

Another important element in the thermal-management kit is the *heat pipe* (**Figure 4**). This passive component is as close to “something for almost nothing” as engineers get, as it moves heat from point A to point B without need for any sort of active forcing mechanism. In brief, a heat pipe is a sealed metal tube that contains a wick and a working fluid. The role of the heat pipe is to draw heat away from a source and convey it to a cooler location, but not to act as a heat dissipating sink itself. The heat pipe is used when there is not enough space at the source to place a heat sink or there is insufficient air flow. It acts as a highly efficient conduit to get the heat from the source to a place where it can be better managed.

How does the heat pipe work? It's simple and clever: It implements a phase change, which is a basic principle of thermal physics. The heat source turns the working fluid to vapor within the sealed tube, and heat-laden vapor carries that heat as it travels to the cool end of the heat pipe. At the cool end, the vapor condenses back into liquid, releasing its heat, and the fluid travels back to the warmer end. This gas-liquid phase-change sequence operates continuously and is powered only by the heat differential between the warmer and cooler ends.

Heat pipes come in many diameters and lengths, with most diameters between about one-quarter inch and

one-half inch, with lengths of several inches to about a foot. As with a water pipe, the larger-diameter pipes have the capacity to convey more heat. When joined with a heat sink or other cooling apparatus at the cool end, it can solve the problem of getting heat away from a local hot spot that has impeded airflow.

Then Add a Fan

Finally, there are fans (**Figure 5**), which mark the first step away from the passive, self-powered cooling of heat sinks and heat pipes to active, forced-air cooling. Fans can be both problem solvers and a headache, and designers often have mixed emotions when using them.

Obviously, a fan adds cost, requires space, and increases the acoustic noise of a system. Also, as an electromechanical device, they are prone to failure, consume some energy, and affect overall system efficiency. However, they are often the only way to get sufficient airflow in many situations, especially when the airflow path is not straight, vertical, and unimpeded. Many applications use thermally controlled fans that run only if needed to reduce their rpm, thus cutting power use, and with blades that minimize noise at the optimum operating speed.

The key parameter that defines fan capacity is the airflow in linear or cubic feet of air per minute. Physical size is also an issue; obviously, a large fan running at lower rpm can produce the same airflow as a small fan at higher rpm, so there is a size/speed tradeoff. Some designs use internal baffles to direct the fan airflow past hot areas and heat sinks for optimum performance.

Models, Simulation Pull It All Together

The decision whether to use passive cooling alone or go to an active forced-air system is often a difficult one. A passive-only system is larger but more efficient and reliable, while a fan allows operation in circumstances that might otherwise be impossible using passive cooling alone.

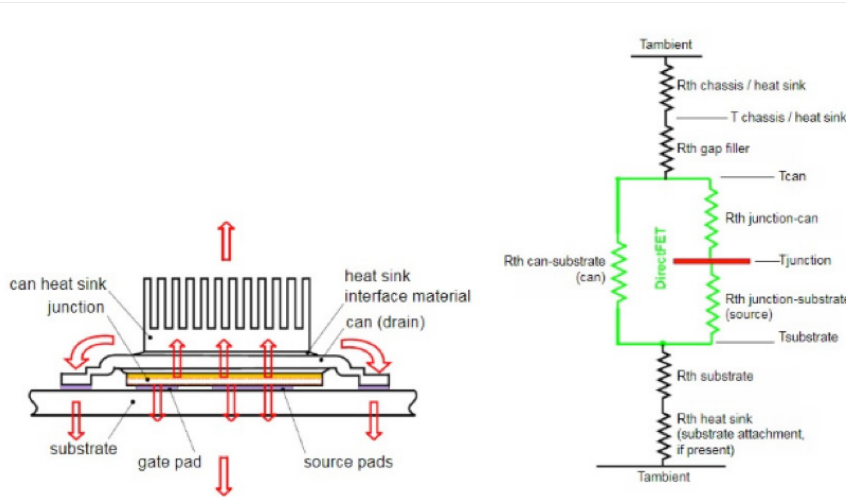

Figure 6: The mechanical model of the installed FET (left) is used to develop an equivalent thermal-resistance model (right), which is used for simulation of the device's thermal situation. (Source: International Rectifier/Infineon)

Of course, there are cases where a passive system alone will be inadequate or impractical. An analogous situation is the management of engine heat in automobiles. The earliest cars with their small engines were passively cooled via fins on the tops of their cylinders as heat sinks. As engines became larger and the heat load increased, these fins became larger and unwieldy, so circulating fluid was added to draw heat away from the fins and bring it to a radiator as a heat sink, through which air would flow as the car moved. This, too, was a passive system. Eventually, though, as engines became even bigger, the passive approach was inadequate and the car would overheat unless it was moving. Therefore, a fan was

added behind the radiator to force air through it, regardless of the car's speed.

Modeling and simulation are critical to an effective thermal-management strategy to determine how much cooling is needed and how to achieve it. The good news is that this activity is far easier and more accurate than most other types of electronic modeling, such as for RF or electromagnetic fields with their parasitics and anomalies.

For micromodeling, the heat source and all thermal paths from it are characterized by their thermal resistance, which is determined by the material used, its mass, and size. This shows how heat will flow from the source and is the first step

in assessing that a component that may be in thermal distress due to its own dissipation, such as a high-dissipation IC, MOSFET, and insulated-gate bipolar transistor (IGBT), and even a resistor. Vendors of these devices often supply thermal models that provide details of the thermal path from source to surface (**Figure 6**).

Note that for some components, their various surfaces may be at different temperatures. For example, the underside of a die may naturally be hotter than the top-side cover of its package, so vendors may design the package to convey more heat to the top to make better use of a top-side heat sink.

Once the heat load represented by various components is known, the next step is macrolevel modeling, which can be both simple and complex. As a first-order approximation, the airflow that passes by the various heat sources can be sized to keep their temperatures below allowed limits. Basic calculations using air temperature, amount of unforced flow available, fan air flow, and other factors will give a rough idea of the situation.

The next step is a more-sophisticated modeling of the entire product and its package, using models of the various heat sources, their locations, the PC board, the enclosure surface, and other factors. This type of modeling

is based on computational fluid dynamics (CFD) and can be quite accurate in showing the temperature at every location in the box (**Figure 7**).

By making “what if” adjustments, designers can see if more air is needed via larger air ports, determine if a different air-flow path is more effective, identify differences in using larger or different heat sinks, inquire about the use of heat pipes to move heat spots, and much more. These CFD modeling packages produce tabular data as well as false-color images of the thermal situation. Changes such as the effects of fan size, airflow, and placement are also easily modeled.

Finally, modelling should address two additional factors. First, there are issues of peak versus average dissipation. A component which dissipates 1W steady state has a different thermal impact than one that dissipates 10W but with a 10 percent intermittent duty cycle. The reason is that the associated thermal masses and heat flow will result in different thermal profiles even if the average heat dissipations the same. Most CFD applications can take this static versus dynamic reality into the analysis.

Second, component-level micro models must take into account imperfections in the physical attachment between surfaces,

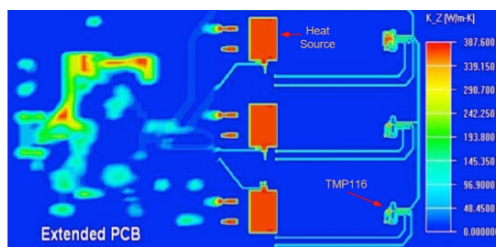

Figure 7: Using computational fluid dynamics (CFD) analysis, the detailed thermal profile across a system or circuit board can be seen, as shown by this PC board with three major heat sources (red) and the flow of heat both left and right on the extended board. (Source: Texas Instruments)

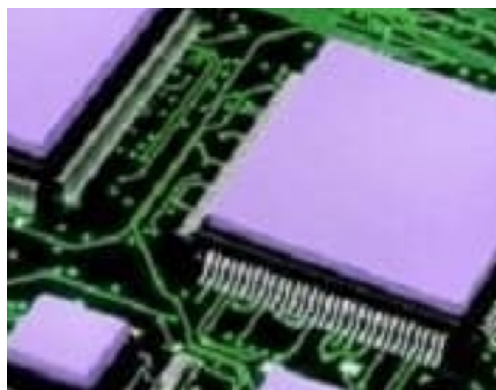

Figure 8: To minimize thermal impedance between an IC and its heat sink, often due to microscopic air voids, users can interpose a thermally-conductive but electrically-insulating pad, such as the [AP PAD HC 5.0 thermal interface high-compliance silicon-based pad](#), with 5.0W/m-K resistance. (Source: Bergquist Company)

such as between the top on an IC package and its heat sink. If that meeting has minute gaps, there will be a higher thermal impedance in that path. For this reason, thin thermal pads are often used between these surfaces to enhance the path’s conductivity (**Figure 8**).

Conclusion

Thermal management is an essential aspect of power management that’s needed to keep components and systems within their temperature limits. Passive solutions begin with heat sinks and heat pipes, and may be enhanced

with active cooling using fans. System modeling at the component level and the complete-product level allows designers to begin a first-order, approximate analysis of the cooling strategy. Further analysis using computational flow dynamics enables comprehensive insight into the complete thermal situation and the effect of changes in cooling tactics. All thermal management solutions involve tradeoffs in size, power, efficiency, weight, reliability, and, of course, cost, and they must be assessed with respect to project priorities and constraints. ●



Drones Ascend to New Heights: Bringing Unique Perspective to Broadening Markets

By Mike Parks, PE, for Mouser Electronics

Fewer emerging technologies have so vividly captured the public imagination as dramatically as unmanned aerial vehicles (UAVs) or as they are more commonly referred to, drones. Their use in military operations over the last two decades has been as game-changing as tanks were to World War I and as rocketry was to World War II.

With all the newfound interest in UAV technology it might be surprising to know that the drones buzzing across the skies today can trace their lineage back to the late 1840s. During the time of the First Italian War of Independence, the Austrians would use unmanned balloons to drop explosives on Venice. The 20th century saw the emergence of remotely controlled aircraft for military training and reconnaissance applications as well as a nascent hobbyist community.

Now in the 21st century, the same technological innovations that have brought us smartphones, the [Internet of Things](#), and wearables have brought us an explosion of drones. What's remarkable is not just the number of drones that are becoming available; it's the applications that they are being applied to that is really incredible. This article explores the types of applications where drones

are solving problems, discusses potential barriers to drone adoption, and explores technical and non-technical solutions needed to help drones reach their full potential.

A Market with Expanding Horizons

Aerial photography and videography are perhaps the two most common uses for drones. Beyond artistic pursuits of photographers and filmmakers, drones allow real estate agents, event organizers, and proprietors of various businesses to easily and inexpensively add stunning visuals to marketing campaigns. The commanding portion of drones sold—some 94 percent of units sold—are for personal use, either as toys or for photography. While personal drones dominate unit sales, the market only represents 40 percent of the revenue generated, according to Recode, a site that focuses on news and trends. The majority of the revenue comes from the relatively miniscule number of higher cost commercial drone sales. And it's in this market that some of the most compelling new use cases and businesses are manifesting themselves as drone technology evolves.

As far as drones themselves, the quadcopter is perhaps the most

prevalent in commercial and hobbyist markets (**Figure 1**). It's a rapidly growing market with hundreds of companies competing at various price points. According to a recent market survey by Recode, drone units sales increased from approximately 1.3 million in 2015 to 2.2 million in 2016. In dollars and cents, those unit sales represented almost 4.6 billion dollars (USD), a 36 percent increase year-over-year. Looking to the future, some analysts are predicting the drone market to hit 6 billion dollars this year (2017) and swell to over 11 billion dollars by 2020.

Emergency and Medical Response

It's not just all fun and games for the future of drones. Many companies are looking to applying the technology to matters where seconds can mean the difference between life and death. Getting lifesaving medications, blood for transfusions, and devices such as defibrillators to a victim quickly isn't always easy in certain locales. Companies such as Zipline have been doing just that in places such as Rwanda where modern healthcare infrastructure just doesn't exist. Less than a year ago, Zipline received approval from the Federal Aviation Administration (FAA) to begin delivery of the same services within the borders of the United States, initially targeting rural or highly remote locations such as Appalachia towns and island communities off the mainland.

Search and rescue (SAR) operations are being significantly helped by the **availability of drones**, too. Large volunteer organizations are sprouting up

to support SAR missions. One such group is S.W.A.R.M. (Search With Aerial RC Multirotor) that claims a network of more than 1,100 volunteer drone operators across 31 countries who are ready to support SAR missions. The drones are not only used to spot lost individuals, but also to deliver supplies such as food, water, first aid kits, and communications devices until rescuers can physically reach the injured individual.

Firefighting presents a great number of dangers to life and limb of human rescuers. Drones are being used to reduce that risk by taking on some of the exploratory tasks so that humans can focus on higher order tasks such as rescuing victims and containing the fire itself. FAROS (Fireproof Aerial Robot System) is one such drone that is equipped with a number of unique technologies that makes it quite suitable for firefighting. Given that firefighting often takes place inside buildings where GPS signals may not be reliable, FAROS adopts additional tools such as an altimeter, 2D laser scanner, and an inertial management unit (IMU) to allow for safe navigation inside buildings. To combat the unusually high heats that firefighting drones are exposed to, FAROS incorporates special materials and design features such as an air buffer and a thermoelectric cooling system.

Industrial and Scientific Applications

Drones are also at the forefront of helping researchers and businesses become more efficient and effective in performing their missions. Agriculture is an industry that is



Figure 1: DJI Phantom 4, an example of a quadcopter drone. (Source: Wikipedia)

leading the charge on introducing technology such as drones to their arsenal of tools in an effort to improve yields and cut costs. DroneSeed is one of a handful of companies in the U.S. that has received government approval to allow a single operator to control multiple drones at the same time. Their drone swarms are responsible for spreading seeds and pesticides as well as monitoring crop growth. Operating in a swarm means serving more farmland in less time and at less cost.

Facility managers are also keen to adapting their business services in response to the wide availability of drones. Tasks such as inspections of roofs, photovoltaic panels, wind turbines, power lines, and roadways are being made safe and efficient thanks to coupling drones with cameras equipped with high definition or infrared imaging sensors. Construction planning and site surveys are also benefiting from drones equipped with LIDAR sensors that allow for centimeter accurate mapping of potential building sites.

In addition to planning for the future, drones are proving to

be equally useful for those who study the past. With drones archaeologists can now do for themselves what they have been relying on small plane pilots or stagnant satellite imagery to do in studying potential sites for excavations. Researchers from the University of Cambridge in the UK have eagerly applied drones to their research at a site known as the “British Pompeii” in Cambridgeshire. Drones allow them to get high-quality, low altitude imagery so they can better plan where to dig thus saving time onsite. In addition, the imagery is used to visually document finds as they are uncovered.

One other novel emerging use for drones is to provide airborne Internet access points, which could prove useful in situations such as disaster recovery, high participation events such as sporting events, or in less-developed parts of the world where the costs of installing traditional telecommunication infrastructure is just too cost prohibitive. Facebook just recently completed their second test flight of a 737-sized (in terms of wingspan) solar-powered drone, dubbed Aquila, to do just this, according to Business Insider.

Entertainment and Sports

In 2016 ESPN, the juggernaut sports television network, inked a multi-year deal with Drone Racing League (DRL) to televise the nascent leagues global competitions. Drone racers represent widely diverse demographics not typically found in traditional sports. Drone racing is also breaking geographic barriers. In addition,



Figure 2: SPAXELS are akin to fireworks shows, using drones instead of pyrotechnics. (Source: Ars Electronica)

the technology aspects appeal to a younger demographic, which could be crucial to attracting and maintaining a subscriber base for old media businesses that are otherwise suffering from a marketplace that’s increasingly embracing cord-cutting.

If watching one drone zipping around the skies is exciting, watching an entire swarm of drones is downright mesmerizing. That’s exactly what Ars Electronica Futurelab thought a few years ago when they set out to create something akin to a fireworks show, with drones substituted for pyrotechnics. The result was something they call the “SPAXEL”. According to the Ars website, “The term SPAXEL is derived from “Space Pixels”; SPAXELS are visual elements positioned freely and dynamically in space. We use drones to carry a **LED lighting system** and combine them into a beautiful and organic swarm of

airborne lights.” Their work along with partner **Intel** resulted in a stunning 500 drone light show late last year (**Figure 2**). Intel would go on to buy the company behind SPAXELS, Ascending Technologies.

Barriers to Drone Adoption

If drones can bring all this good to bear on today’s problems, then what is stymying their ability to reach their full potential? For some with a dystopian worldview, drones with high definition cameras represent the potential for regular invasion of privacy.

Safety is another major concern raised about the proliferation of drones. From falling out of the sky and injuring an innocent bystander to catastrophic interaction with manned aircraft, there are many scenarios that could result in property damage or worse. While many issues could be solved technologically, certainly human

error or malfeasance is likely to play a role much like problems that arise from people and automobiles.

From the perspective of people and organizations that are keen to eventually embrace drones, perhaps the biggest complaint regarding the current generation of drones is the limited flight time that today's batteries can sustain. Lack of sensors in drone-friendly form factors or interoperability issues between the sensor and drone are another stumbling block that has to be worked out as well.

Overcoming Barriers: Technology and Regulatory Solutions

The world is only beginning to witness the ascent of drones as useful tools and not just amusing novelties. It will take a combination of both technological and non-technological solutions to help drones reach their full potential. Across the world, RC clubs and other aviation focused groups are offering training courses for new drone pilots. In the U.S., until a recent court ruling, the FAA required all non-commercial drone operators who flew drones weighing between 0.55lbs (250 grams) and 55-lbs to register with their Small Unmanned Aircraft System (sUAS) Registration Service. Other rules apply to drones larger than 55-lbs. Even with the recent court ruling, the registration issue is likely not a settled matter yet. If the drone operator intends to engage in a commercial enterprise then they would be subject to a certification process as laid out in FAA Part 107 Certification for Commercial Drone Pilots.

From a technology perspective, there's plenty of lucrative opportunities for innovations in drone friendly hardware and software. A popular accessory for many camera-equipped drone operators is a pair of First Person View (FPV) goggles. Such goggles place the view from an onboard camera and place it squarely in front of the operators eyes making it feel as if they were sitting in a non-existent cockpit. FPV goggles rely on solid, high-speed **radio links** that minimize latency while also maximizing image resolution and distance achievable between drone and operator. Encryption of the data link will also be increasingly critical as more and more drones take to the sky becoming targets of convenience for those with than less noble intentions.

Improvements in battery capacities and onboard **power management** will be a major boon for the continued adoption of drones. Better batteries will lead to improved flight times and/or weight handling capacities, which in turn leads to more efficient flight operations and inclusion of more hardware to add functionality. More efficient **electromechanical components**, such as motors that drive the propellers or camera gimbals, will also go a long way to help with power consumption.

Better flight control, enabled by intelligent onboard **sensors** and systems, will go a long way toward addressing the safety and privacy concerns associated with drones. Already drones at increasingly lower price points are being equipped with GPS and/or GLONASS navigation systems to help drones keep track of where

they are located. Virtual walls known as geofences tell drones areas that they should avoid even if told otherwise by their operator. Of course, knowing where these geofences are (and keeping that information current) is a more complex challenge. Often this challenge is addressed on higher-end drones by requiring them to connect over a Bluetooth or Wi-Fi connection to a smartphone-based application to keep a geofence inventory current. Other technologies such as IMUs, barometers, infrared-based object detection, and computer vision solutions can also be incorporated to provide a more holistic picture of the operating environment to allow for safer flight.

Lastly, as more sensors and higher resolution cameras are incorporated, the **brains** of the drones must also improve to handle all the data being thrown at it. Machine learning algorithms that could be used in object detection and collision avoidance will require a significant bump in onboard **processing power**. Drone swarms of any significant size will also add networking to the mix of challenges that must also be addressed. Whether **mesh networks** or some other dynamic network topology is embraced, every drone that is intended to operate in a swarm will have to have the ability to communicate efficiently and in fairly unpredictable environments. Of course, all this must be balanced with the fact that additional computing horsepower can become a significant burden on a device that must expend most of its energy just to keep itself in the air. Which is the whole point of having a drone to begin with. ●



New PV Cells Benefit Energy Harvesting

Enhanced energy harvesting using new materials and construction techniques meets demands of niche applications

By Steven Keeping for Mouser Electronics

Today, some 85 percent of the installed of **photovoltaic** (PV) cells are manufactured from silicon, as it's both particularly suited to turning light into electricity and plentiful. Too, PV cells can be produced in volume by adopting wafer manufacturing techniques pioneered by the integrated circuit (IC) industry. However, silicon has some downsides, including a maximum efficiency of around 33 percent, energy-intensive high temperature processing, and fragility.

Alternative PV technologies using new materials, architectures, and assembly techniques have been developed to address silicon's drawbacks. New materials include the compound semiconductors gallium arsenide (GaAs) and gallium phosphide (GaP), as well as the mineral perovskite (CaTiO₃); the new energy-focusing concentrated PV (CPV) architecture and assembly techniques use multi-junction, thin-film, and large crystals for high energy efficiency and durability.

While silicon PV cells are likely to dominate large-scale electricity generation due to mass production and falling prices, alternative

technologies will find use in niche applications. One such application is **wireless IoT sensors** where efficient, compact, durable, and inexpensive PV technology could harvest solar energy to charge the devices' batteries. Such technology would be a boon for the **Internet of Things** (IoT) roll-out because it would enable wireless sensors to operate reliably with little or no maintenance.

This article explores how PV cells work, the role of silicon, and the advantages and disadvantages of silicon as the underlying semiconductor, as well as the potential of new semiconductors, architectures, and assembly techniques.

Photovoltaic Process

Although a deep understanding of the photovoltaic (also called photoelectric) process requires familiarity with quantum mechanics, the basic principles of PV cell operation are relatively straightforward: PV cells take advantage of semiconductor *p-n* junctions. In the *n*-type material, electrons act as current carriers, with electron vacancies or "holes" doing the same job on the *p* side of the junction.

When a photon within a narrow band of wavelengths enters the semiconductor crystal matrix, there is some probability that it will be absorbed by an electron bound to an atom in the *n*-type material, endowing the particle with sufficient energy to escape from its parent atom. The excess electrons on the *n*-type side of the junction then diffuse across the junction to recombine with holes on the *p*-type side, creating a potential difference across the joint. The incorporation of a conducting return path between the two sides of the joint allows a direct current (DC) to flow (**Figure 1**).

A PV cell is made up of thousands of these *p-n* junctions and multiplies the effect—and, hence, the magnitude of the current. In the commercial product, these cells are combined to form modules and ultimately create panels. The DC voltage can be turned into AC by an inverter to do useful work or send power directly to the distribution grid (**Figure 2**).

First Generation PV Cells: Single-Junction Silicon

First-generation PV panels are largely fabricated from a crystalline form of silicon (“c-Si”). The key drivers for silicon’s large uptake is its PV performance and convenience of supply. The bulk material is plentiful (making up 28 percent of the Earth’s crust), and the techniques and facilities for manufacture have been borrowed from the chip industry. However, processing the large-scale silicon wafers for PV panels is energy intensive, complex, and expensive.

Cost has been mitigated in part due to excess global manufacturing capacity; the price of silicon PV

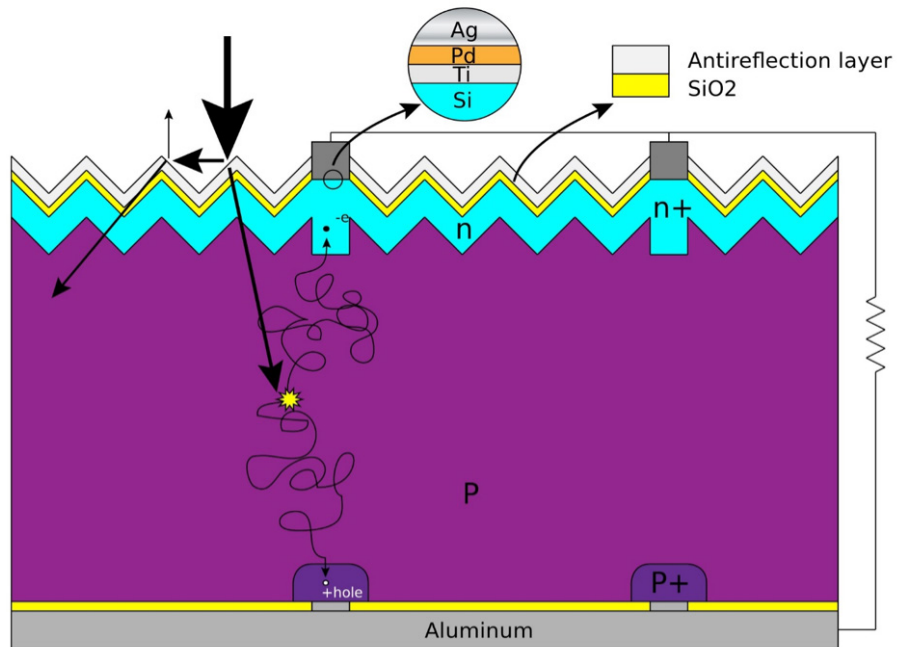

Figure 1: Single-junction PV cell operation: Photons of appropriate energy liberate electrons, which cross the semiconductor junction and generate a potential difference. (Source: Cyferz at English Wikipedia)

panels has declined by around 30 percent in the last year alone. Government subsidies designed to encourage the uptake of silicon PV panels to reduce reliance on fossil fuels for electricity generation have also played their part in encouraging adoption. Nonetheless, the technology remains too costly for many niche applications.

Silicon Advantages: Efficiency and Band Gap

Silicon offers several advantages for PV technology. First, its PV efficiency is good. (Efficiency is defined as the percentage of energy generated by a PV panel compared with that incident upon its surface in the form of light.) Averaged out over the surface of the planet, the Sun delivers around 1100W/m² when directly overhead. A PV panel measuring 1m² exposed to this level of sunlight and exhibiting 10 percent

efficiency, for example, will output around 110W.

The key characteristic that limits a semiconductor’s maximum efficiency is its band gap. The band gap defines the amount of energy required to liberate an electron from an atom (into the “conduction band”) and is measured in electron volts (eV); 1eV is approximately equal to 1.602×10⁻¹⁹ J.

The energy of photons is determined by their wavelength, with photons of a shorter wavelength (higher frequency) being more energetic. Many sunlight photons entering a c-Si lattice will carry insufficient energy to liberate an electron and will therefore do little more than heat up the material. Photons with greater energy than that required to bridge the band gap might liberate a single electron, but their excess

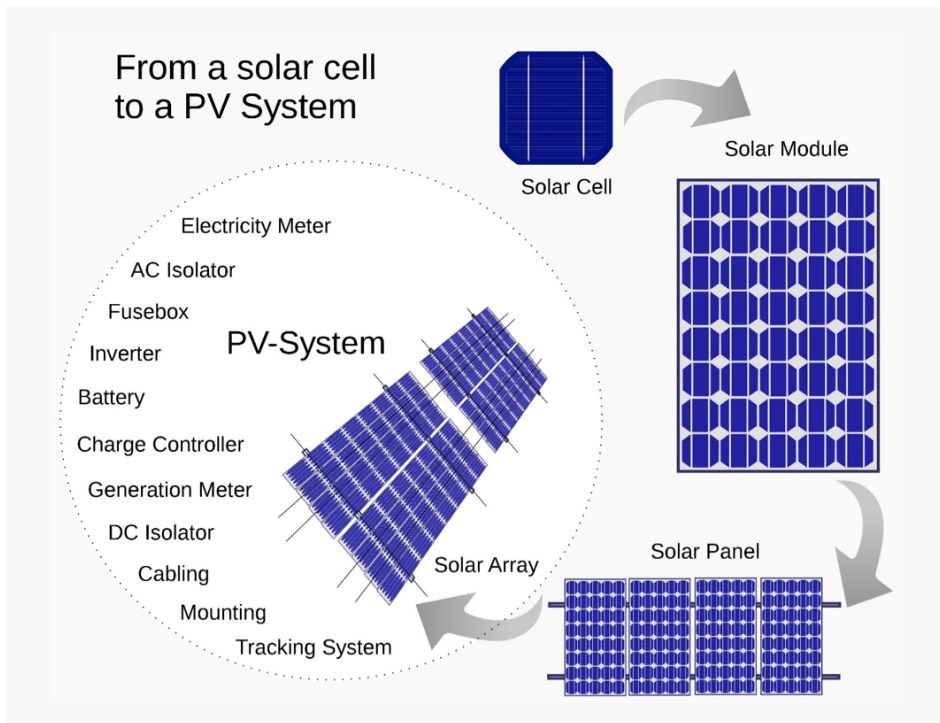

Figure 2: PV cells are combined into modules and then into panels to form end products. (Source: Wikipedia)

energy will again just contribute to heating up the crystal rather than doing anything useful.

In 1961, William Shockley and Hans-Joachim Queisser calculated the theoretical maximum PV efficiency for single-junction (cells made of just one semiconductor) PV cells across a range of band gaps (**Figure 3**). The calculation revealed that the optimum band gap for a single-junction PV cell was 1.13eV, which yielded a maximum efficiency of around 33 percent. It turns out that silicon's band gap of 1.10eV is close to the optimum figure.

Silicon Drawbacks: Crystal Size, Energy, Efficiency, and Fragility

Silicon as a material is not perfect for PV cells, however. For example, band gap is not the

only determinant of efficiency; crystal size also has a major effect. If a material is made up of small crystals, electron mobility is reduced by the large number of crystal interfaces. Reduced mobility restricts current flow and, in turn, efficiency.

Additionally, these drawbacks further hinder silicon as an ideal semiconductor for PV cells:

- Maximum theoretical efficiency is just 33 percent. The best commercial c-Si PV panels achieve around 24 percent efficiency in practice wasting over three-quarters of the sun's energy.
- Fragility, requiring mechanical support from heavy glass panels, adding weight and cost.

- Energy-intensive, high-temperature, and complex processing.
- Inherently expensive, which could introduce challenges if supply becomes restricted and/or subsidies are withdrawn.

New Developments in PV Technology

In the last several years, second-generation PV products have been commercialized, and third-generation technology has entered the R&D labs. Second- and third-generation technologies look to build on the success of mature silicon technology, particularly the established support infrastructure—such as isolators, meters, controllers, and inverters that are largely independent of the PV technology type—while addressing some of silicon's drawbacks.

Second-Generation PV Technology

Second-generation PV panels focus on nanometer- to micrometer- thick layers of PV material mounted on a glass, plastic, or metal substrate. These “thin-film” PV (TFPV) cells (also called “multi-junction” products because of the additional active layers) are cheaper and less energy intensive to manufacture, use less expensive material, are low in weight, and are suited to applications such as semi-transparent, PV glazing material that can be laminated onto windows (**Figure 4**).

The downside of TFPV panels is that the manufacturing, energy, cost, and weight advantages are traded-off against efficiency. Some of the potential efficiency gains of bulk material multi-junction PV panels is

lost because the thin films comprise tiny crystals that affect electron mobility. Instead of c-Si, for example, which comprises comparatively huge crystals, commercial TFPV panels use either polycrystalline silicon (very small crystals) or amorphous silicon (no crystals). TFPV panels promise efficiencies of 20 percent although today's commercial products typically operate at 10 percent efficiency.

A second disadvantage of TFPV panels is relatively rapid degradation of the thin films reducing the panel lifetime. Second-generation PV cells are unlikely to challenge silicon's dominance for large-scale electricity generation but offer promise in applications where lower cost, weight, and durability can be traded-off against efficiency.

Third-Generation PV Technologies

PV technology is continually being developed to enhance first- and second-generation technologies. And research into new areas is uncovering technology that will form the foundation of a third generation of PV product. These developments and research generally fall into four sectors:

- **Materials:** Complementing silicon with semiconductors

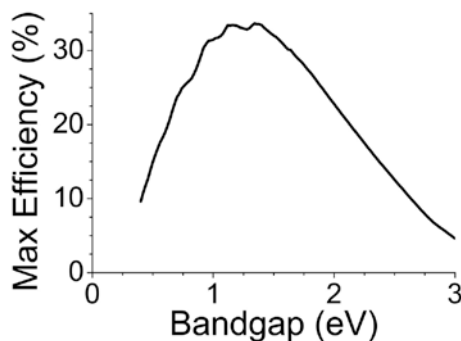

of different band gaps so that photons of lower energy can liberate electrons and so that those of a higher energy convert more of that energy to electricity.

- **Structure:** Introducing techniques that lower the energy intensity and complexity of first-generation PV panel production.
- **Processing:** Improving semiconductor processing techniques to enhance the quality and size of crystals such that electron mobility is raised.
- **Mechanical:** Amplifying the number of photons that fall on a unit area of substrate by focusing incident light with mirrors or lenses.

Material Developments

Converting more of the incident photon energy into electricity is possible by introducing materials with lower and higher band gaps than silicon. Silicon's band gap of 1.1eV is the best of any single semiconductor for harvesting energy from visible light. However, much of the energy from the sun is carried by photons with energy below this band gap. And although, for example, a blue-light photon can carry three times as much energy as a red one, two-thirds of

that energy is wasted even if the photon is absorbed by a silicon electron.

Semiconductors with band gaps lower than silicon enable photons that would otherwise be useless to contribute to the PV effect. Indium arsenide (InAs), for example, has a band gap of 0.36eV and has been used successfully to complement silicon.

Semiconductors with higher band gaps than silicon allow more of the energy of shorter wavelength photons to contribute to electricity generation. Materials such as gallium arsenide (GaAs), which has a band gap of 1.43eV, and gallium phosphide, which has a band gap of 2.25eV, have also been used with success. Several lines of research have also resulted in further compounding of these materials—for example, indium gallium arsenide (InGaAs) and indium gallium phosphide (InGaP)—to further optimize the PV effect.

Structural Developments

Alternative band gap semiconductors have a lower maximum efficiency than silicon alone, so there is no benefit in employing them singly. Instead, one or more semiconductors are used together in a multilayer structure. Materials with the largest band gap—requiring short wavelength (high energy) photons to dislodge electrons—are positioned at the top, allowing low energy photons to pass through without interaction to then be absorbed by lower band gap materials in the following layers. Transparent conductors are required at each layer to carry the generated current yet let photons pass through to the lower layers.

Figure 3: Shockley and Queisser's calculation of maximum efficiency against band gap for single-junction PV cell semiconductors. Silicon has a band gap of 1.1eV. (Source: Wikipedia)

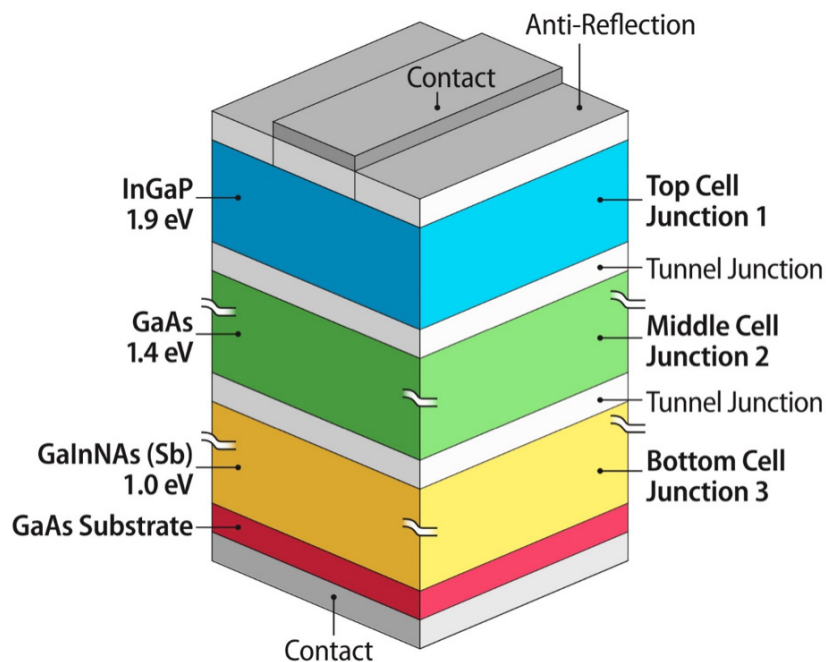

Figure 4: Multi-junction TFPV cell internal structure. (Source: NREL)

This technology has been deployed with success in TFPV panels and remains the focus a key area of research.

Silicon has a maximum efficiency of 33 percent, but this figure can theoretically be bettered by multilayer PV panels. A two-layer cell, for example, with one layer featuring a band gap of 1.64 and the other 0.94eV, could reach a maximum efficiency of 44 percent. Similarly, a three-layer PV cell with band gaps of 1.83, 1.16, and 0.71eV, would have a maximum theoretical efficiency of 48 percent. Commercial multilayer products comprise two, three, or four layers.

Processing Developments

Researchers are investigating new groups of materials for third-generation PV panels that combine the high efficiencies of the first

generation with the simpler and cheaper manufacturing of the second.

One group of materials that has caused much excitement is derived from the mineral perovskite (CaTiO). The group of materials has band gaps ranging from 1.4 to 2.5eV. The theoretical maximum efficiency of the perovskite group can't match silicon, but recent rapid efficiency gains from around 4 to 20 percent have raised hope that commercial products will eventually be more efficient than TFPV panels.

The key advantage of the perovskite group over silicon is the comparative ease and low processing temperatures with which millimeter-sized perfect crystals can be grown. This is a huge size for a perfect crystal lattice, and it dramatically increases electron mobility and

hence efficiency while slashing manufacturing costs. Current lines of research are aimed at growing even larger perfect crystals; for example, researchers at MIT in the U.S. have recently discovered how to “heal” crystal defects in a perovskite-based PV cell by exposing the cell to intense light.

Elsewhere, researchers at University of California, Berkeley have discovered that different facets of the perovskite crystals have markedly different efficiencies. The scientists are now focusing their research on ways of processing the bulk material such that only the most efficient facets interface with the PV cell electrodes as a method of boosting overall efficiency.

As with TFPV materials, a key challenge currently limiting the commercial deployment of perovskite-based PV cells is the speed at which the material degrades.

Mechanical Development

Another development objective for third-generation PV panels is concentrated PV (CPV) technology. CPV is designed to focus sunlight using lenses and mirrors such that a dramatically higher number of photons fall on a unit area of PV panel. The technique typically employs high-efficiency, multi-junction PV cells constructed, as shown in **Figure 4**. Focusing the light increases efficiency, enabling dramatic reductions in panel size, lowering the cost and weight of the product, and increasing the number of locations where it can be installed.

“Low” CPV focuses the equivalent of two to 100x sunlight onto

	Cell effic. (%)	Module effic. (%)	Record commercial and (lab) efficiency, (%)	Area/kW (m ² /KW) ^{a)}	Life-time (yr)
c-Si					
Mono-c-Si	16 - 22	13 - 19	22 (24.7)	7	25 (30)
Multi-c-Si	14 -18	11 - 15	20.3	8	25 (30)
TF					
a-Si	4 - 8		7.1 (10.4)	15	25
a-Si/ μ c-Si	7 - 9		10 (13.2)	12	25
CdTe	10 - 11		11.2 (16.5)	10	25
Cl(G)S	7 - 12		12.1 (20.3)	10	25
Org.Dyes	2 - 4		4 (6-12)	10 (15)	na
CPV	na	20 - 25	>40	na	na

Table 1: Efficiency of c-Si, TFPV, and CPV technologies (Source: IRENA)

the panel, while “high” CPV can multiply the light to the equivalent of 1000x sunlight. CPV systems often use solar trackers and sometimes a cooling system to increase efficiency. **Table 1** summarizes the efficiency of current PV cell technology.

Case Study: Energy-Harvesting Wireless IoT Sensors

The key application for PV technology is for renewable-energy generating capacity to feed the electricity grid. But third-generation technologies—which promise less expensive, more durable, and smaller PV panels—promise to introduce energy-harvesting niche applications.

Wireless IoT Sensors

Designers of IoT wireless sensors have long been keen to take advantage of energy harvesting. It is envisaged that the IoT will comprise billions of sensors with many positioned remotely and therefore isolated from main

power and difficult to access for maintenance such as battery changes.

Many of the products will employ low power wireless technologies such as Bluetooth low energy and zigbee, which have been designed from the ground up to run from modest power resources. Many applications are powered from compact primary cells with capacities around 220mAh. In low-duty cycle operation, the average current draw from a low-power wireless System-on-Chip (SoC) is in the microampere range, extending battery life to thousands of hours (several months) of operation.

However, extending battery life by replacing a primary battery with a secondary battery and recharging via a PV cell extends self-contained operation to several years.

Energy-Harvesting Technology
Energy harvesting technology for small-capacity, Li-ion cell charging is a proven technology.

For example, **MikroElektronika’s energy-harvesting module** is a silicon PV cell capable of producing up to 0.4W at 4V.

Because the voltage and current from a PV cell varies considerably, the voltage/current output from such a device needs to be regulated for Li-ion battery charging. (Li-ion batteries require careful current/voltage management during the charging cycle.) Purpose-designed, highly-integrated **power management chips** are available for the job.

For example, **Maxim’s MAX17710 power management IC** can manage poorly-regulated sources such as PV cells with output levels ranging from 1 μ W to 100mW. The device also includes a boost regulator circuit for charging the battery from a source as low as 0.75V. An internal regulator protects the cell from overcharging. 3.3, 2.3, or 1.8V outputs are supplied to the wireless IoT sensor via a low-dropout (LDO) linear regulator.

Texas Instruments also offers a power management IC, the **bq25504**. The device is specifically designed to efficiently acquire and manage power generated from PV cells. The chip integrates a DC-DC boost converter/charger that requires only microwatts of power and a voltage as low 330mV to commence energy harvesting (**Figure 5**).

Third-Generation PV Technology Applied

While current PV cell energy-harvesting solutions work satisfactorily, they do have some downsides. For example,

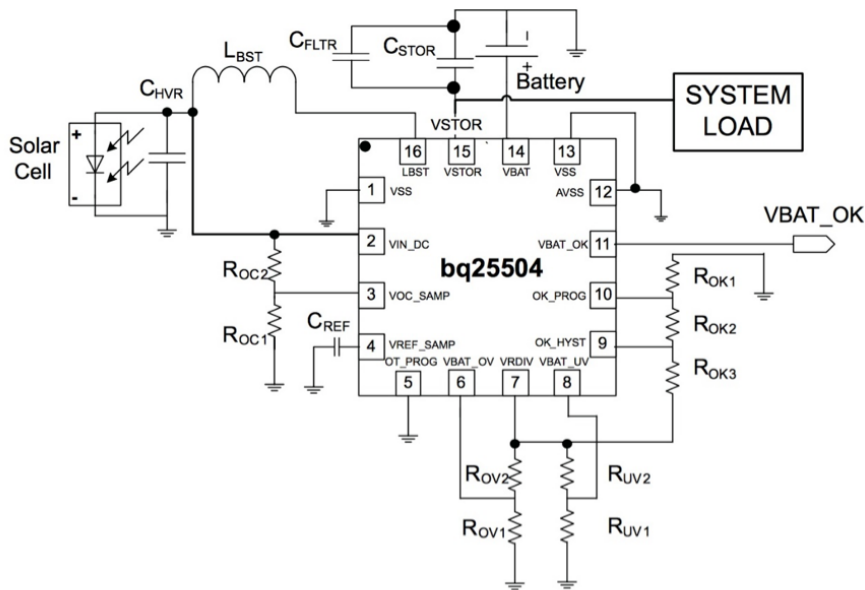

Figure 5: Application circuit for energy-harvested battery charging using TI power management IC. (Source: Texas Instruments)

MikroElektronika’s energy-harvesting module measures 7 × 6.5 × 0.3cm (a surface area of 45.5cm²), is relatively heavy and fragile. However, silicon PV cells like this product are currently the only practical choice because of their efficiency compared with alternatives.

But third-generation cells incorporate technology to boost efficiency beyond the current 10 percent enjoyed by commercial products. Technologies currently in the lab are projected to double efficiency in the next several years; that would introduce silicon PV cell-type performance to TFPV cells combined with advantages of lower cost, light weight, and greater robustness.

A third-generation TFPV cell measuring just 4cm² in direct sunlight, for example, would receive around 0.22W incident power. At 20 percent efficiency, the TFPV cell would output around

44mW. While charging at an average of 3.5V (voltage varies during a Li-ion battery charging cycle), the current supplied from the power management chip would be around 12mA, sufficient to fully recharge a 300mAh Li-ion battery in around 25 hours.

While such a charging regime would take several days of full sunshine, note that the Li-ion battery will only discharge at a rate of a perhaps a few mAh per day under typical low power wireless sensor operation, requiring the PV cell to only top-up the battery (rather than fully charge) ensuring it can easily cope with the energy demand even on days without full sunshine.

Compact third-generation PV cells are yet to be commercialized. And when mass production does commence, prices are likely to initially be too high for wireless IoT sensor applications. However, as the technology matures and

demand increases, TFPV cells will become much cheaper and a practical proposition for this niche application.

Simultaneously, the efficiency of TFPV PV cells will continue to increase, bringing greater advantages to energy-harvesting wireless sensor designs including:

- Energy harvesting from artificial light for indoor sensors.
- Reduction in panel size for given power output for highly space-constrained designs.
- More power available to run complex software algorithms on advanced wireless SoCs.
- Increased wireless sensor range and throughput.
- Multiple sensors powered from a single PV panel.

Conclusion

An estimated 85 percent photovoltaic (PV) cells currently installed are manufactured from silicon, as it’s both plentiful and suited to turning light into electricity. Second- and third-generation PV technologies are addressing silicon’s downsides that include a maximum efficiency of only about 33 percent, energy-intensive high temperature processing, and fragility.

Second-generation PV panels focus “thin-film” PV cells that are mounted on a glass, plastic, or metal substrate. These are cheaper and less energy intensive to manufacture, use less expensive material, are low in weight, and are suited to applications such as semi-transparent, PV glazing material that can be laminated onto windows. These are unlikely to challenge silicon’s dominance for

large-scale electricity generation but offer promise in applications where lower cost, weight, and durability can be traded-off against efficiency.

Third-generation PV cells promise even more by matching the efficiency of silicon while building on the advantages of second-generation products. This will make the cells a good option for remote, low-maintenance IoT sensor applications using rechargeable Li-ion batteries continually replenished by the sun's energy. These PV technologies use new materials, structure, processing, and mechanical techniques to address silicon's drawbacks. New materials include the compound semiconductors gallium arsenide (GaAs) and gallium phosphide (GaP), as well as the mineral perovskite (CaTiO₃); the new energy-focusing concentrated PV (CPV) architecture and assembly techniques use using multi-junction, thin-film, and large crystals for high energy efficiency and durability.

Niche applications like energy-harvesting wireless IoT sensors, which require efficient, compact, durable, and inexpensive PV technology, stand to benefit from third-generation PV cells. Such technology would enable wireless sensors to operate reliably with little or no maintenance. As third-generation PV technologies evolve, we can expect to see additional wireless sensor designs, such as harvesting energy from indoor lighting and other applications that require compact, efficient, powerful, and robust designs. ●

Key Takeaways

- Silicon is the market-leading material for general-purpose PV panel applications because the raw material is plentiful, manufacturing infrastructure is established, and it offers high efficiency.
- Silicon PV cells have some notable downsides: They are heavy, fragile, energy intensive to produce, and expensive.
- This makes silicon impractical for energy harvesting applications for compact wireless IoT sensors.
- New materials and PV cell construction techniques address silicon's drawbacks, but lower efficiency limits usefulness for wireless IoT sensors.
- Improved efficiency promised by third-generation cells will make the technology suitable for wireless IoT sensors, and promises to increase computational power, wireless range, and throughput at an affordable cost.



The Future of Healthcare May Reside in Your Smart Clothes

By Peter Brown for Mouser Electronics

Smart clothing technology is still in its infancy, but the idea of weaving electronics into a shirt, a blanket, a bandage, a knitted cap, or pants to perform specific functions has the potential to solve a variety of patient treatment and monitoring scenarios in the medical industry.

When most people think of *wearables*, they often think of the obligatory smart watches, fitness monitors, and **heart rate monitors** that are typically worn on the wrist or arm. However, the wearables market extends well beyond just these standard devices and into multiple emerging markets across some different industries.

One such emerging market is *smart clothing* for healthcare—the idea of weaving electronics into a shirt, a blanket, a bandage, a knitted cap, or pants to perform specific patient care functions.

Smart clothing, or *e-textiles*, as a whole is still in its infancy, and practical applications that are being used in hospitals and other care facilities are few and far between.

Yet, interest in the potential of this technology is vast with many healthcare providers and medical device manufacturers actively monitoring smart clothing pilot projects and research into the latest e-textiles technology. In fact, smart clothing holds such promise in healthcare it is being seen as a major disruptive force in the industry in the next five years.

“Healthcare in general is experiencing its own crisis especially in the US (also in the UK),” said Aditya Kaul, research director for market research firm Tractica. “Therefore, the focus is more on fixing healthcare rather than on technologies like smart clothing. We see a slow growth for the market in the next three to four years, but beyond that, we see a bright, fast growing market.”

Tractica forecasts smart clothing for healthcare to grow from just \$2.4 million today to a whopping \$1.2 billion by 2021, with the majority of growth coming in the years 2019–2021.

What is an e-Textile and How Does it Work?

Smart clothing is seen as a way to revolutionize the practice of healthcare, and it’s hoped that a widespread use of garments used to monitor health or help with treatment could reduce reliance on costly equipment and a heavily burdened healthcare system. Clothing that can track chronic disease or conditions, help with a growing aging population, or make patients more comfortable during a stay at a hospital or treatment

facility is seen as a way to create value, boost health insights, and reduce costs.

E-textiles are designed to feel comfortable on the skin but at the same time be functional. These smart fabrics consist of traditional fabric woven with conductive fibers as well as electronic elements such as biomedical sensors, microcontrollers, fiber optics and wearable antennas, such as Mouser's line of Internet of Things system-on-modules.

An example of a biomedical sensor that could be used in e-textile applications is the [Analog Devices' AD8232/33 Heart Rate Monitor Front End](#). It is an integrated signal conditioning block for ECG and other biopotential measurement applications, designed to extract, amplify, and filter small biopotential signals in the presence of noisy conditions. The [Intel® Edison development platform](#) is designed to lower the barriers to entry for a range of inventors, entrepreneurs, and consumer product designers to rapidly prototype and produce Internet of Things (IoT) and wearable computing products. It is both a system-on-module solution and an item that incorporates a wearable antenna.

In some cases, e-textiles are created, in part, on a typical tabletop sewing machine that embroiders thread into fabric in a pattern via a computer program. Instead of thread, however, metallic fibers from metals such as silver, nickel, carbon, copper, aluminum, and stainless steel, like [Adafruit's wearable electronic platforms](#) from Mouser, are used that feel the same as traditional thread to the touch.

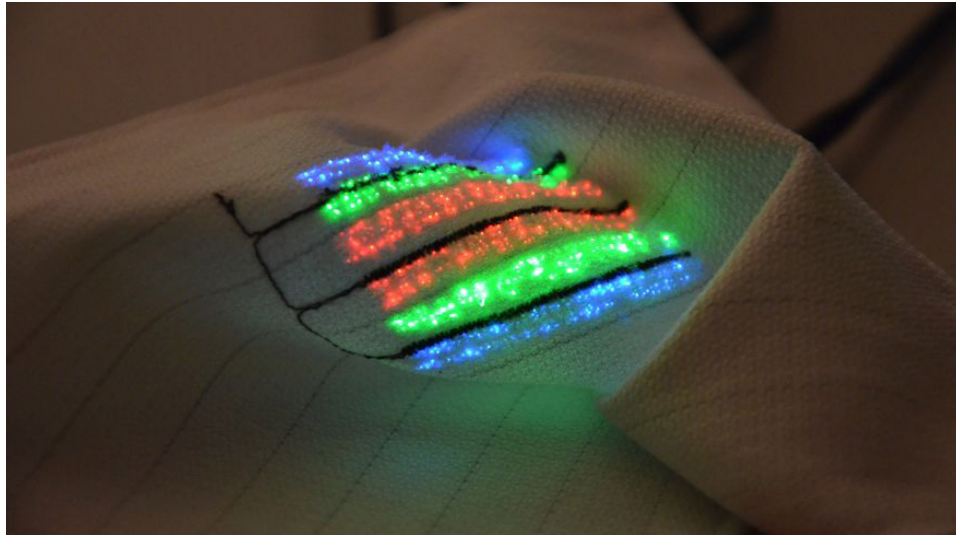

Figure 1: Fiber optics integrated into a blanket or shirt in order to monitor skin circulation to prevent bed sores or monitor heart rates is what researchers at Empa are working on. (Source: Empa)

These products allow you to realize any wearable project. They are fully featured, round, sew-able, and Arduino-compatible devices. They are small enough to fit into any project and low cost enough to use without hesitation.

Depending on how the conductive fibers are woven in and the electronics included in the smart clothing, the fabric is durable and able to be washed similar to regular clothing. While durability is still an ongoing issue in many projects, it is a consideration that most researchers and companies are working on as an important step toward mass commercialization of smart clothing for healthcare.

Market Drivers and Challenges for Smart Clothing

So far, there have been relatively few e-textile commercial successes. One of the reasons for this is a lack of willingness by companies in the

healthcare field to invest in research projects or academics instead taking a wait-and-see approach. In its place, some manufacturers have turned to the wellness/sports market where the consequences for a wrong signal are much lower.

However, with a continued rise in many parts of the world of chronic disease--such as diabetes, heart disease, cancer and respiratory disorders--aging populations that are living longer and an increase in the number of surgeries performed in key healthcare markets such as Europe and the US, e-textile developments are on the rise to make use of [emerging electronics](#) and medical technology. In some clinical trials, smart clothing has shown to protect against infectious disease, help sense the state of the wearer's health, and help prevent, treat, and manage health.

“There are lots of opportunities in healthcare development, especially



Figure 2: A wearable, washable stocking that can be worn at home for use in monitoring edema in patients' legs is moving into the clinical trial and validation phase. (Source: Edema ApS)

textiles,” said Luciano Boesel, group leader for adaptive textiles and hydrogels at Swiss research house Empa (**Figure 1**). “The need for long-term, unobtrusive monitoring of risk patients at home will stimulate quick development. In five years’ time, I believe we’ll get to see many innovative textile solutions in healthcare.”

Boesel admits e-textiles face challenges that must be overcome including further development in reliability, liability, and certification. Regulatory approvals also present a challenge for device manufacturers and researchers as FDA consent can take many years. Then getting approval and certification from

insurance companies is another hurdle. So many smart clothing projects that have been introduced will take between three to five years to come to fruition. Many experts see this inflection point happening in the 2020 time frame.

Solving Current Problems

James Hayward, technology analyst with market research firm IDTechEx, believes that if an immediate financial or economical gain to the technology can be had, the more likely smart clothing will be adopted by providers.

E-textiles such as a bed sheet or mattress that are integrated with pressure sensors to manage and

prevent bed sores by making sure the patient is moving around on the surface enough is something that is garnering a lot of interest from companies, Hayward says. Conditions such as bed sores and incontinence in the elderly cost hospitals and care facilities money and time. Moisture sensors integrated into smart clothes for mapping incontinence in patients could prove to be a very worthwhile investment in the long run.

“If e-textiles continue to prove to be successful, it will start off as a high-end luxury feature before it gets adopted on mass,” Hayward said. “These things take time and while typical medical device lead



Figure 3: Ohio State University is working on integrating antennas and circuits into clothing for the future of healthcare monitoring and treatment. (Source: Ohio State University)

times are coming down slightly, we can expect to see some in five years, more in 10 years. But there is a lasting value here, so I do think it will come to healthcare gradually.”

Clothing+ is working with Jabil to mass produce textile-integrated sensors that meet the necessary FDA requirements for medical grade solutions. Some of the ideas for the e-textile include a bioimpedance vest, which measures water accumulation in the lungs to indicate heart conditions, that can be worn at home for trend analysis before hospitalization, saving time and money. Other ideas in development is a chest belt to provide a lung’s performance

through a topographic picture of the lungs and a light therapy blanket for babies with jaundice allowing them to be removed from cradle light therapies and held by parents or loved ones instead.

Edema ApS is developing a washable stocking to measure and monitor changes in leg volume with patients suffering from edema (fluid accumulation or swelling) in the lower limbs (**Figure 2**). While not yet available for patients, the stocking is being prepped for clinical trials and validation. Future uses of the stocking could be to monitor congestive heart failure or pre-eclampsia, which happens during pregnancy and involves

hypertension, edema, and protein in the urine.

“The stocking will be washable and durable enough for home use, which is the main concept idea of the project. Being able to monitor people when they are home and avoid long problematic trips just to have an eye assessment of the increase or decrease,” said Klaus Østergaard, CEO of Edema. The stocking would be monitored via a smartphone app where the user could self-regulate during exercise, identify the need to elevate or reposition legs or call the doctor for medical adjustment, Østergaard says.

Wearable body metrics vendor



Figure 4: Researchers at the University of Bristol are working to integrate soft robotics into clothing to support those vulnerable to falls or have trouble walking up stairs. (Source: University of Bristol)

Hexoskin has been active in developing smart clothing for sports/fitness markets but is also working on e-textiles for healthcare in the areas such as cardiology, respiratory, neurology, mental disorders, and pediatrics. Currently, Hexoskin is **conducting trials** for long-term remote monitoring of clinical-grade sensors woven into a smart shirt for precise electrocardiography (ECG) cardiac monitoring with lung function and activity monitoring.

Academia Leading the Way

Among those developing e-textiles for the healthcare market, work being done at the university level offers much promise for the future of patient care technology.

One interesting project is being developed by VTT Technical Research Center of Finland, where

researchers have created smart fabric that can be used as clothing or blankets that calculate whether a patient needs to be cooled or warmed based on the initial date measured from the person and the environment. These garments could also be used by surgeons that get too hot during an operation with the clothing adjusting to the temperature of the body during surgery.

“Hospital patients have been asked about their most unpleasant experience, and the most common answer is feeling cold—pain comes only second,” said Pekka Tuomaala principal scientist at VTT.

Ohio State University’s ElectroScience Laboratory is working toward functional e-textiles that gather, store or transmit digital information by

weaving antennas—such as the Intel® Edison development platform—into something like a brain cap that senses activity in the brain to help treat conditions such as epilepsy or addiction (**Figure 3**). The researchers are also working on a smart bandage that tells a doctor how well the tissue beneath it is healing without removing the bandage.

“Our goal is to understand how we think. Imagine if we can enable our brain into regeneration. To do that we need to understand the brain and how many neurons are working together,” says John Volakis, director of the ElectroScience Laboratory at Ohio State University. “These smart clothes could tell an epileptic person to sit down before they have an attack or how to activate or deactivate cells in patients with Parkinsons.”

Meanwhile, the University of Bristol is working on **soft robotic clothing** that could help vulnerable people avoid falls by supporting them while they walk and giving others bionic strength to move between sitting and standing positions or climb stairs (**Figure 4**). The smart clothing involves nanoscience, 3-D fabrication, electrical stimulation, and full-body monitoring technologies. Researchers believe this technology could ultimately lead to potentially freeing wheelchair-bound people from having to use the devices.

“Many existing devices used by people with mobility problems can cause or aggravate conditions such as poor circulation, skin pressure damage or susceptibility to falls,

each of which is a drain on health resources,” said Dr. Jonathan Rossiter, professor of robotics in the Department of Engineering at the University of Bristol. “Wearable soft robotics has the potential to improve many of these problems and reduce healthcare costs at the same time too.”

Switzerland’s Empa research center is integrating optic fibers into e-textiles to monitor the skin’s circulation to prevent bed sores and has created a fitted cap that measures heart rates. The garments are being made to withstand a disinfection wash cycle, which would make it ideal for hospitals.

Researchers believe this technology could be used eventually to measure oxygen saturation or to measure pressure on the tissue or respiration rate. The e-textiles could also be turned into chemical or biosensors, such as those offered by Maxim Integrated to analyze body fluids or vapors. Maxim’s ultra-low power and secure development boards are based on Maxim’s series of ultra-low power ARM® Cortex®-M microcontrollers. **These ARM Cortex-M4F 32-Bit MCUs** are ideal for the emerging category of wearable medical and fitness applications because their architecture combines ultra-low-power, high-efficiency signal processing functionality, and ease of use. The **Maxim MAX30102 Pulse Oximeter & Heart-Rate Sensor** is an integrated pulse oximetry and heart-rate monitor module, and it includes internal LEDs, photodetectors, optical elements, and low-noise electronics with ambient light rejection.

“The ductility of the fibers has to match that of textile yarn to provide the same comfort and integrity,” said Dr. Maike Quandt, a postdoctoral researcher at Empa. “E-textiles benefit from fiber optics since the fibers can be used for a multitude of sensors. At the same time, optical fibers do not pose a risk for electric shock.”

The Future of Smart Clothing

While many of these academic endeavors are moving forward and are working toward commercialization, **innovations** in high-tech fabrics and the advances in microelectronics are opening even further possibilities for healthcare-related e-textiles.

Some of these ideas and early pilot projects involve t-shirts that relieve chronic back pain, shirts with stretch sensors for monitoring respiratory rates with patients with chronic lung disease, soft all-day belly bands that monitor uterine contractions and fetal heart rate in pregnant women, pressure monitor stocking for use by diabetic patients or even a shirt that delivers shocks to patients experiencing serious heart problems.

Some experts see smart clothing completely replacing bedside monitoring in hospitals with shirts that track heart rate, blood pressure, oxygen intact and more.

Recently, the idea of integrating gesture recognition in smart clothing has garnered attention with the Google-Levi Project Jacquard commuter jacket for bicycle riders. While many experts believe gesture recognition could find its way into clothing

for healthcare—maybe for use by paraplegics or elderly that have had strokes or heart attacks or elderly in the home that fall—currently there are far less expensive and established technologies that will be hard to surpass in the next five years.

Haptic feedback, or the use of touch in a user interface design, holds much promise in e-textiles because it can be easily miniaturized and does not require moving mechanical parts. Haptic feedback would be used in Electric Muscle Stimulation (EMS) that could range from a small tingle to a strong force feedback to activate a patient’s muscles. Smart clothing with haptic feedback technology could be used at all times during the day and worn on any part of the body to stimulate muscle movements or rehab. Projects involving haptic feedback, such as those from Novasentis, are currently in development for use in garments for healthcare with prototypes expected to arrive later this year. ●





Digital Twins Offer Unmatched Insights for Design Engineers

By Michael Parks, PE, for Mouser Electronics

For every physical product, there is a virtual counterpart that can perfectly mimic the physical attributes and dynamic performance of its physical twin. Digital twins offer engineers and product designers unmatched insights that can yield higher quality products and better product support at less cost and less effort.

The value of a new technology is not always obvious from the get-go. Apart from a “killer application” that makes the use case blatantly evident, innovative ideas can sometimes remain just that—ideas. That is, unless a market develops for these ideas or additional innovations come along that make the whole greater than the sum of the individual technologies.

The **Internet of Things (IoT)** is arguably one such innovation that some might say is a solution in search of a problem. The term IoT was coined by technology pioneer Kevin Ashton back in 1999; however, it has not been until recently that enough factors—wide availability of inexpensive embedded sensors and proliferation of wireless Internet, for example—have coalesced to make the IoT a feasible technology that is ready for mass adoption. A technology, however, is not necessarily a solution by itself. A subset of the IoT, known as the **Industrial Internet of Things (IIoT)**, has seen some respectable success in the manufacturing market. Still, the cost of implementing IIoT technologies,

especially in circumstances where the technology would have to be retrofitted into operational facilities, is not chump change. That said, the IoT and the IIoT have plenty of forward momentum and appear to be on a course for a rendezvous with another innovative concept that has been percolating for over a decade itself—the idea of the *Digital Twin*.

History of the Digital Twin

The idea of the digital twin is the brainchild of Dr. Michael Grieves and John Vickers (originally used in 2003 at a course at the University of Michigan), who are experts in manufacturing and product lifecycle management (PLM). The basic notion is that, for every physical product, there is a virtual counterpart that can perfectly mimic the physical attributes and dynamic performance of its physical twin. The virtual twin exists in a simulated environment that can be controlled in very exact ways that cannot be easily duplicated in the real world, such as speeding up time so that years of use can be simulated in a fraction of the time. These hyper-accurate models



and simulations offer engineers and product designers unmatched insights across the entire product development cycle. Still, digital twins are more than just an evolution of digital models, although their goal is similar: Higher quality products and better product support at less cost and less effort.

From the Factory...

For decades, engineers and designers have heavily relied on software design applications to digitally capture their ideas for physical objects as parametric models. Even today, more complex software allows for the simulation of certain characteristics such as thermal properties or stresses and strains. While use of simulations in product design is nothing new they have historically relied on relatively small data sets or engineering assumptions when making predictions. Digital twins, however, have access to unfathomably large data sets thanks to the IIoT. Sensors that monitor literally every facet of a product's lifecycle can be measured and fed back into an iterative

design-manufacture-observe-improve loop.

... to Your Door

Once a product leaves the factory and is acquired by an end-user, the digital twin can begin to feed off real-world data collected by the onboard sensors. This is where perhaps the concept of the digital twin reaches its full potential. Sensors in the end item itself will track key performance characteristics of the device as it operates in real-world conditions.

Comparing actual telemetry against the predictions of the various aspects of the digital twin model yield insights that could only be dreamt of until now. A fortuitous loop results from this level of integration of the physical and virtual. Not only can the digital twin be improved based on real-world data, but future iterations can also be improved based on better understanding of actual data from end users. In some cases, where changes can be made through a firmware update, products that have already been shipped can also benefit from lessons learned

through using a digital twin.

In addition to product telemetry, the external operating environment—ambient temperature, relative humidity, and so on—can also be analyzed by onboard sensors, so such factors can be accounted for in simulations. This type of information is invaluable in debugging errant device behavior by providing some operational context that would just not be possible otherwise. For example, if there are two products that are otherwise used and maintained in similar fashion but one keeps failing regularly, it might of interest to the engineers that product that is consistently failing is being used at very high elevations. Being able to get that feedback to a company would be invaluable. Not having to rely on a customer to call a help desk and to have that data fed into a digital twin to influence future design iteration is even more incredible. In addition, it would be almost magical if a customer received an email from the company proactively describing steps they could perform to minimize the failures

that they might be experiencing without having the customer even place a call or email in the first place.

All of this data—both performance data and external factors—can be communicated in real-time back to the equipment manufacturers to improve the digital twin model and simulation factors. The digital twin could then analyze the operational data and predict failures if it sees data points outside of prescribed tolerances. For example, a circuit board might be seeing higher than expected operating temperatures or motors that are experiencing an unusually high number of stop-start cycles. The digital twin could determine with some level of confidence that the part will fail shortly and take a series of approved actions, such as placing an order with the company responsible for manufacturing the failing part and alerting a technician that they need to brush up on the process for replacing the component. As a result, any downtime is minimal and relatively predictable.

Beyond the obvious use of these rich datasets in maintenance prognostics, digital twins could have profound impacts on the design and engineering of subsequent product iterations. Understanding how a product is actually being used in an objective and data-driven manner will lead to faster development cycles and greatly reduce the time to detect product defects or identify useful tweaks, thus reducing waste by allowing manufacturers to make real-time improvements to the products still coming off the assembly line. This can translate to huge savings by avoiding costly rework.

Digital twins are not limited to assessing tweaks to physical properties of a design. Digital twins can also make it easier to study the impacts that software and firmware revisions have on performance. Various configurations and settings can be rapidly tested and assessed to determine which ones will deliver optimum performance. Firmware updates could then be pushed out seamlessly to all the devices, leveraging the same Internet connection that initially sent the data used to identify improvements.

Furthermore, complex systems such as wind turbine farms could also benefit from the application of digital twins from a system-of-systems perspective. Having multiple instances of a single product, each with their digital twin that communicates with all the other digital twins, means that products can begin to learn from each other. The aggregate knowledge that a digital twin represents can help augment the capabilities of trained human operators in ways to allow them to be more efficient and effective without having to manually collect and crunch the data before making major decisions. Therefore, digital twins allow technology and humans to work together while letting each focus on what the other does best. Technology can continuously monitor, collect data, and conduct analysis. Meanwhile, humans can keep their attention on higher-level work such as exploring implications of various complex courses of actions and making informed decisions.

The Future: More AI, Big Data Interaction

Embedded platforms, with their computational horsepower, energy efficient sensors, and reliable

communications hardware, are critical to the collection and dissemination of telemetry data. This data is necessary to make digital twins smart enough so that their function is worthwhile. Then, all that data can be pumped into databases that are rapidly analyzed using Big Data techniques. Throw in the possibilities from a Watson-like Artificial Intelligence (AI) system to analyze and make improvement recommendations, and it's possible that products could improve over time without any human intervention. The result is the ultimate in technology self-help! Digital twins might very well prove to be the long sought after use case that finally makes the adoption of the IoT mainstream. The implications of a more cost-effective, rapidly moving, and increasingly intelligent product development lifecycle would seem to make any investment well worth it.

For some, the value of digital goes way beyond just parts and products. Some see a future where every aspect of our lives—from our cars and homes to entire cities and even the human body—will be given a digital twin as a way to encourage experimentation and see what tweaks can be made to improve the quality of our lives. The success or failure of all these potential digital twin candidates will come down to the ease in which the lifeblood of a model—the data—can be collected, aggregated, and disseminated. This data and the associated dataflow, the so-called digital thread, will undoubtedly be fed to digital twins via the IIoT. Perhaps the digital twin is the killer app that the IIoT has been waiting for all these years. Or so my digital twin tells me. ●

BEST OF WEBINARS

Think Like a Hacker



Now Available On Demand

Presented by Mouser Electronics in partnership with [Anitian Corporation](#)

When your job is to create and build embedded systems and products, intentionally breaking your creations seems wrong. But not to a hacker. They do not see your systems and products as elegant designs that solve problems. Hackers see your product as a means to an end. When we look back over the past 20 years of cybersecurity and data breaches, almost every incident has some type of exploitation of a vulnerability—perhaps a poorly designed API or a third-party component with outdated code. This is what cybercriminals, malware writers, and state-sponsored hackers obsess over: How to break what you build.

If you want to build more secure, more resilient embedded systems and products, you have to look at them the way a hacker does. This means identifying potential vulnerabilities, prioritizing security as a design requirement, and then integrating security into every dimension of system and product development. In partnership with Mouser Electronics, Anitian security experts will discuss how you can start looking at your embedded system designs and architecture the same way a hacker does. Attendees will learn how to improve development practices to integrate security at every stage.

Key Takeways

- Understand how systems get hacked
- Learn ten areas of embedded systems and products that hackers focus on
- Discover how to add security to the product development process

Best of Empowering Innovation Together

In the 2017 [Empowering Innovation Together \(EIT\) series](#), Mouser teamed up with celebrity engineer [Grant Imahara](#) and Wired Brand Lab to look the role of technology in making [cities of the future smarter and more efficient](#). In the 5-part video series, Grant Imahara traveled the globe to explore where humanity is heading and what companies are driving us there:

- Introduction
- [Roving Hot Spots in Porto, Portugal](#): See how Veniam is transforming the city into a Wi-Fi mesh network comprised of mobile hot spots.
- [Vertical Farming in Tokyo, Japan](#): See what ideas are growing inside the world's largest indoor farm.
- [Constructing the Future in Los Angeles](#): See how DAQRI is developing AR products and technologies that enhance human capabilities in manufacturing applications.
- Conclusion



Best of EIT eBooks: Vertical Farming

- Urban Farming: Technology Grows Along With Crops
- Improving Energy Efficiency in Vertical Farms
- Connectivity Boosts Crop Yields and Quality
- Sensors Help Farmers and Make Positive Impact
- Harvesting New Ideas with LED Lighting Networks
- Robotics Offer Boosts in Indoor Farm Efficiency

Best of Other EIT Content

A lot of outstanding content came from 2017's EIT project. Here are some of the most popular and significant articles and blogs:

- Augmented Reality: Beyond Gaming to Real-World Solutions
- My Way on the Highway
- Solar Roads Pave the Way for Connected Infrastructure
- Vertical Farms Thrive With Help From Technology
- Conquering Vertigo: MEMS in Augmented Reality

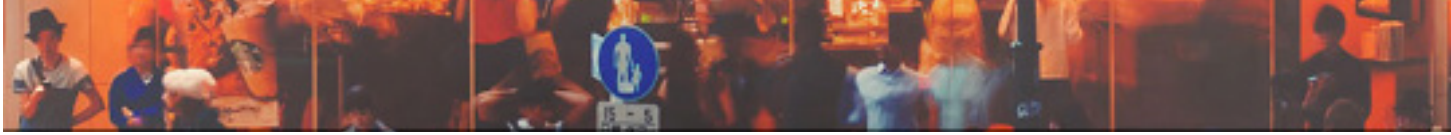

Augmented Reality: Beyond Gaming to Real-World Solutions

By Peter Brown for Mouser Electronics

Ask a stranger off the street what Virtual Reality (VR) is or how it works, and most people will have some inclination of what the technology entails, maybe even equating it to the ultimate VR implementation in the Holodeck from the television series “Star Trek: The Next Generation.” However, ask that same person about Augmented Reality (AR), and the answers are less likely to be easily gained. Maybe someone will talk about the gaming aspect of the technology or its earliest incarnation in the failed Google Glass.

While the idea of AR has been around for a while, it didn’t garner worldwide attention until the launch of Pokémon Go, the video game that combined smartphone imagery with a real world scavenger hunt to let gamers experience both real and virtual worlds. But what, exactly, is AR? And as a burgeoning technology, does it offer potential beyond gaming and entertainment as a solution to real-world problems? This article explores a variety of AR pilot programs and applications across multiple industries, including healthcare, law enforcement, education, logistics, construction, and more. As you’ll see, AR is being transformed into a platform for use across multiple industries for practical uses—a technology that could go from simple pilot projects today to something people use every day as part of their daily lives.

What is Augmented Reality?

Augmented reality, or sometimes called *mixed reality*, is a technology that merges real world objects or the environment with virtual elements generated by sensory input devices for sound, video, graphics or GPS data. Unlike virtual reality, which completely replaces the real world with a virtual one, AR operates in real-time and is interactive with objects found in the environment providing an overlaid virtual display over the real one.

While popularized by gaming, AR technology has shown a prowess for bringing an interactive digital world into a person’s perceived real world, where the digital aspect can reveal more information about a real-world object than is seen in reality. Imagine doctors being able to see inside a patient during an examination, rather than by viewing scans and x-rays. Imagine kids learning about molecules by being able to interact with them. Imagine being able to see what maintenance and repairs are needed on a piece of machinery just by looking at it.

Devices that power augmented reality are typically dedicated Head-Mounted Displays (HMDs) or Head-Up Displays (HUDs) like harnesses (such as Microsoft’s HoloLens), helmets or glasses, and handheld devices such as a smartphone or tablet. Products like [Intel’s Recon Jet™ Pro Smart Glasses](#) integrate smartphone capabilities into lightweight glasses, enabling see-what-I-see interfacing with remote Enterprise Resource Planning (ERP) systems. More than just a display module, these glasses enable users to see through the eyes of others at remote locations. Some vendors are branching out using other objects to generate augmented elements such as a projector, table, or lamp, or through a flat panel display itself. With these advances, AR users wouldn’t be hindered by the need for bulky headgear or glasses.

The Next-Generation of Healthcare

With the high costs of healthcare not going away any time soon combined with an aging population in many regions, medical technology is looking to help not just cut the costs for hospitals, providers and insurance carriers but also provide better, less invasive techniques toward treatment. Augmented reality has found a home here with the technology



Figure 1: A doctor uses HoloLens and augmented reality software to see ultrasound while directly in front of a patient. (Source: University of Maryland)

being used as a preventive measure to provide healthcare professionals to receive data in a non-traditional way.

Healthcare giant Cigna just this year launched a program called BioBall that uses Microsoft HoloLens technology in an interactive game to test for blood pressure and body mass index. Patients hold a light, medium-sized ball in their hands in a one-minute race to capture all the images that flash on a screen in front of them. The BioBall senses a player's pulse and uses responsive light to connect the game with the player's heartbeat. Once the game is over, patients receive their health numbers privately in their headsets with suggestions offered to be sent to an associated email address. Cigna says the technology is a way to encourage people to take control of their health by knowing their health numbers, so treatment then can be garnered accordingly.

Over at the University of Maryland's Augmentarium virtual and augmented reality laboratory, the school

is using AR in healthcare to improve how ultrasound is done (**Figure 1**). Using a Microsoft HoloLens and special software, physicians wearing an AR device can look at both a patient and ultrasound imaging directly in front of them instead having to look at a bulky screen off to the side, says Barbara Brawn-Cinani, Associate Director for University of Maryland's Center for Health-Related Informatics and Bioimaging (CHIB).

And ultrasound is only the beginning for AR. "We're only scratching the surface on surgical applications, and we're planning for similar interfaces for other imaging modalities, and also field testing to determine how well this kind of tool actually works," Brawn-Cinani says.

Other companies are working on new platforms that use AR for more complex procedures. Scopis, for example, is developing a tool to give surgeons enhanced vision while performing spinal surgery.



Figure 2: A child uses the Orboot to learn about different weather patterns in a particular part of the country. (Source: Shifu)

Putting Old Knowledge in New Formats

Meanwhile, AR is opening up new ways to teach kids a variety of subjects they might or might not be interested in learning or, in some cases, help those that have trouble in class catch up with the rest of the students. The University of Helsinki in Finland’s AR program helps struggling kids learn science by enabling them to virtually interact with the molecule movement in gases, gravity, sound waves, and airplane wind physics. The university found that AR was enough of a boost for these low-performing children to bridge the gap with other students who were also learning science. It was also shown to help improve the quality of learning in high-performing students.

AR also creates new types of learning by transporting “old knowledge” into a new format. For example, the University of Helsinki says AR for learning became much more appealing because kids had already dabbled with the technology before with Pokémon Go. Similarly, using new technology to teach about the old world is also the idea behind Shifu’s Orboot interactive STEM device (**Figure 2**). Orboot is an augmented reality educational globe that works with a tablet or smartphone for children to learn about history, animals, monuments, language and arts, weather and culture by interacting with 3-D content.

The information is provided through AR-generated 3-D models, voiceovers, and music for a more immersive

experience to learning. The goal is to promote active learning and memory retention that would not be possible with just video content, Shifu says.

The New Boardroom

Projection-based augmented reality is emerging as a new way to cast virtual elements in the real world without the use of bulky headgear or glasses. That’s why this type of AR is becoming a popular alternative for use in the home or office. Start-ups Lampix and Lightform are working on projection-based augmented reality for use in the boardroom, retail displays, hospitality, digital signage and more.

Lightform’s device can attach to any projector, similar to a Go Pro, and can instantly generate augmented reality elements (**Figure 3**). This may be useful for doing work with multiple groups in an office or creating elements for artists in a studio or presenting new products for display in a retail signage application.

“We think the influx point for type of technology is five minutes,” says Phil Reyneri, Design Director at Lightform. “If you are going to be in an extended period time, it makes sense to strap on an AR or VR headset. But if you are doing something that is more of a quick type experience—such as walking through a store or mall—it is more of a frictionless experience. Also you can have many people simultaneously experience augmented reality because there is not expensive headset that an individual has to wear.”

Lampix has developed a lamp that uses a projection module, vision module, and a computer to project augmented reality on a surface that becomes active. Because no headsets or glasses are needed, the lamp-type device could be placed in a boardroom, where collaborative efforts could be worked on both on and off site, says Lampix CTO and co-founder Mihai Dumitrescu.

“AR has to be seamlessly integrated into everyday life in order to make sense. When it gets to that point, applications are endless, and it really has the potential to improve and make a lot of our activities more fluent,” Dumitrescu says. “The focus should not be on the technology itself but much more on the experience. Lampix has a great potential



Figure 3: This device connects to any projector to create augmented reality elements for retail, home or office use. (Source: Lightform)

to accomplish this because it is technology that vanishes into the background. You do not need to see the device, it is just the experience that emerges, that is meaningful and useful.”

From Finding Tiny DNA to the Vastness of Space

Meaningful and useful is what companies and think-tanks are working on worldwide. In fact, augmented reality is finding its way into just about every industry and market, at least in a pilot phase. In Germany, for example, FleetBoard is in the development phase of an app that tracks logistics for truck drivers to help with the long series of pre-departure checks before setting off. The FleetBoard Vehicle Lens app (**Figure 4**)

uses a smartphone and software to provide live image recognition to identify the truck’s number plate. Then the relevant information is superimposed in augmented reality, speeding up the pre-departure process.

FleetBoard is also working with Microsoft’s HoloLens to create a new way to manage truck fleets. On an abstract road map, the surface is brought to life with augmented reality allowing fleet manager’s to monitor vehicles live in a 3-D landscape to prevent accidents and delays, and to warn drivers of possible problems on the road ahead.

Last winter, Delft University of Technology in the Netherlands started working with first responders to



Figure 4: FleetBoard Vehicle Lens app is a pilot project that tracks a truck's number plate and superimposes the information in augmented reality. (Source: FleetBoard)

use AR as a tool in crime scene investigation. The handheld AR system allows on-scene investigators to work with remote forensic teams to minimize the potential for contamination. AR is also seen as a way to have multiple sets of eyes on a crime scene that normally wouldn't have more than just the first responder there. This could be extremely helpful in finding traces of DNA, preserving evidence, and getting medical help from an outside source.

Sandia National Laboratories is working with augmented reality as a tool to improve security training for users that are protecting vulnerable areas such as nuclear weapons or nuclear materials. The physical security training helps guide users through real-world examples such as theft

or sabotage in order to be better prepared when an event takes place. The training can be done remotely and cheaply using stand-alone AR headsets.

In Finland, the VTT Technical Research Center recently developed an augmented reality tool for the European Space Agency (ESA) for astronauts to perform real-time equipment monitoring in space. Because these tasks must be carried out without errors and at the right time, AR prepares astronauts with in-depth practice by coordinating the activities with experts in a mixed-reality situation. The tool makes the invisible visible by enabling the visualization of telemetry data from equipment and other systems on board the space station such as diagnostics and the latest maintenance data, life cycle,

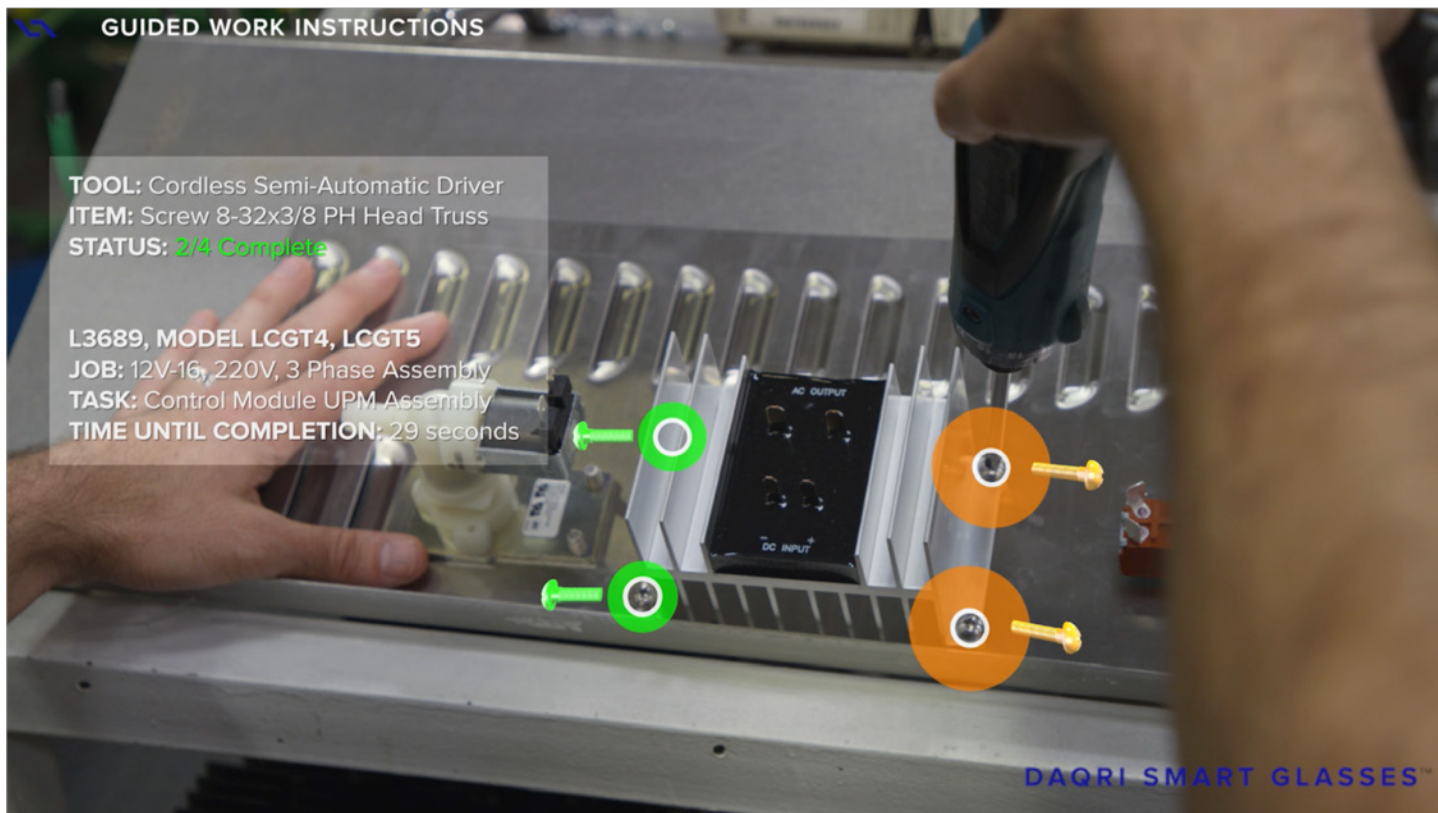

Figure 5: Workers view the task that needs to be completed as a visual element in DAQRI's AR headset or glasses. (Source: DAQRI)

radiation, pressure, or temperature—both in space and on the ground and displayed on AR glasses.

In the U.S., DAQRI International uses computer vision for industrial AR to enable data visualization while working on machinery or in a warehouse. The glasses and headsets from DAQRI display in the field of view project data, tasks that need to be completed, and potential problems with machinery or even where an object needs to be placed or repaired. Using AR can improve safety and efficiency in an industrial job space while making repairs, maintenance and inventory management easier.

Conclusion

Augmented reality merges real world objects or the

environment with virtual elements generated by sensory input devices for sound, video, graphics or GPS data. AR operates in real-time and is interactive with objects found in the environment providing an overlaid virtual display over the real one. Although Pokémon Go continues to be popular with gamers, companies around the world are already demonstrating the potential for using AR to solve real-world problems and needs. Industries such as law enforcement, education, logistics, construction, and others are prototyping and using AR technologies and reporting promising outcomes, such as training, monitoring, and collaboration that's more effective and efficient. As for the future of AR? With continued development of AR technologies, the reality of widely-used practical applications is on the horizon. ●



My Way on the Highway

Life Inside Autonomous Vehicles: Beyond the Mobile Workplace

By Sylvie Barak for Mouser Electronics

The trend toward autonomous vehicles is transforming how cars are designed and marketed, with a shift in emphasis from car exteriors to interiors, and a shift from engine performance to personalized passenger experiences.

The National Highway Traffic Administration defines autonomous driving levels using a scale of zero to five, with zero indicating no autonomy and five being fully autonomous. Level four or five autonomy is a mere two to five years away, according to experts interviewed in this article, as well as CEOs at the world's largest automakers interviewed in a recent *Venture Beat* article. At stage four, vehicles are considered fully autonomous, "designed to perform all safety-critical driving functions and monitor roadway conditions for an entire trip." Level four, however is "limited to the operational design domain (ODD) of the vehicle, meaning that it does not cover every driving scenario." And a level-five vehicle? That refers to a "fully autonomous system that expects the vehicle's performance to equal that of a human driver." Humans would need to do nothing but sit back, relax, and do whatever it is they decide to do in their driving pods.

The technological leap to levels four and five is, relatively speaking, not very far off, but they will profoundly change vehicle architectures from the inside out, turning them from being basic transportation to being fully fledged mobile living spaces. It will also change people's relationships with their cars, ownership models, and passenger culture, and it will become a major disruptor to established industries like rail and domestic flight.

Passenger-Focused Vehicle Interiors

Without drivers in the picture, car designers will be free to focus on the passenger, without being tied to standard configurations like front facing seats and

windows designed specifically for maximum visibility. What manufacturers will do with that freedom, however, is still up for debate.

"We might be looking at something initially that's almost akin to business class seating on airplanes," said Greg Lindsay, a journalist, urbanist, futurist, and a senior fellow of the New Cities Foundation. "Something with an entertainment function that retracts into a full-length bed. That could be the early prototype of a hybrid entertainment/work/sleeping space. That may sound prosaic, but then again, a lot of the time we spend is already pretty prosaic," explained Lindsay.

Those ideas are on the conservative side of the spectrum, however. Others are already discussing the possibilities of mani-pedi pods, mobile exercise environments, meditation spaces, family rooms, sports bars on wheels, and a variety of other social settings. Sizes and shapes of cars may also change to accommodate the interiors. Sleeper cars may need room to accommodate five beds instead of five seats, or whatever else a family decides it needs on a long road-trip.

There are also the futuristic visions of fish tank-type conference rooms hurtling down the highway, though not everyone is enthused by the car becoming a mobile workplace. "That would be the worst. I mean, you take a blank canvass, and you just extend your workday by a couple of hours? That sounds like the worst!" said futurist Michael Vidikan. "Swiveling chairs, video interface desk, collaborative workstation. That kind of interior is easy to put together," he said, noting that the potential for creativity is so much bigger.

Sleep and Meditation Pods

"The car will become a place where you can tend to your mind body and soul," said Johnnie Rush, another



futurist, former Disney Imagineering executive and self-proclaimed 'Cool Hunter.' "You don't have to be aware of traffic or accident control. Things that people typically struggle to find time to do, like exercise or meditation, will be accommodated for in the autonomous car," he said, adding that he envisions the car as a place people could exercise or meditate, a mini gym where they could use a reclined bike, or rowing machine, or even practice some reclining yoga.

The concept of health is becoming increasingly important throughout the Western World, with people spending ever more money on wellness products. The car is the next logical evolution to that trend, with designers looking carefully at trends like mindfulness and meditation and how to apply those concepts to car interiors. With windows no longer being important for visibility and with audio feedback no longer essential for safety, car interiors could potentially provide a blackout, soundproof environment that acts as a sort of sensory deprivation chamber to help travelers destress on their commute.

Not convinced of this potential use? Consider that stress-related health issues are responsible for up to 80

percent of doctor's visits in the U.S. and account for the third-highest health care expenditures, behind only heart disease and cancer, so the benefits of being able to destress on-the-go have significant ramifications.

New parents, who on average accumulate something of a six-month sleep deficit in the first year of a baby's life could also potentially benefit from the sleep and relaxation aspects of autonomous vehicles. Infants are typically soothed to sleep by the car's motion, so sleep deprived parents would be able to take advantage of the car's autonomous nature to catch up on some sleep themselves, or at least be in an environment conducive to rest and self-care.

Media Center on Wheels

Meditation and sleep aren't the only types of relaxation we may want to do in our cars, however. Most futuristic visions of the autonomous vehicle include a plethora of screens in all shapes and sizes.

Today, with advances in material science in areas pertaining to things like graphene—which is both electroconductive and bendable—the entire interior of a car

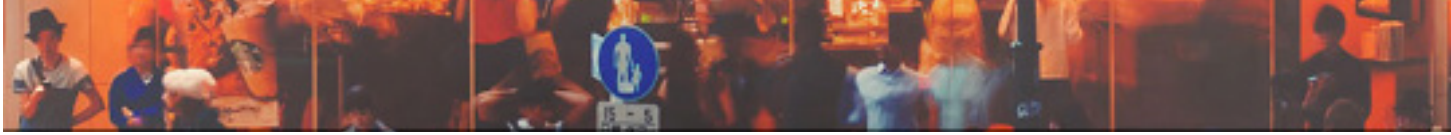

could be a screen of some sort, a type of futuristic time machine, where you could transport yourself into a virtual reality on wheels, surrounded by sound and light. Designers could add in elements of sensory perception like smell or vibration. “Your vehicle could become a 360-degree pod for media consumption where you can consume things in a way you couldn’t anywhere else,” noted Rush, who believes autonomous vehicles will become the ultimate media centers.

Graphene also has the ability to be transparent when it’s not electrified, so it could also potentially be used for window surfaces, which in turn could all become screens, or partial screens, opening up opportunities for augmented reality (AR) overlaid on the world zooming by outside. “Imagine driving through historical parts of the country, and having your car’s AR point out interesting landmarks along the way, like a virtual and interactive tour guide,” said Chris Rockwell, a user experience consultant on a quest to help inform and inspire design through a deep understanding of people, their experiences, and their aspirations. “The autonomous car will provide people with multi modal types of mobility experience, a combination of mobility and freedom,” he said.

Others, like Lindsay, are less convinced about the AR/VR interiors. “Coupling the nausea of VR with the nausea of a moving vehicle doesn’t seem like a fun idea, but who knows?” he said, noting that, in fact, nausea may be the real limiting factor when it comes to what people can and will do as passengers.

“It’s going to be things like nausea, or the fact that the American road system is falling apart.”

Multi-Purpose Modules

Customizing car interiors is all well and good, but people have different whims, fancies, and needs on any given day. So what’s a designer to do? “I don’t think cars would do as well being defined with permanent interiors as well as if they were designed to be able to flexibly shift between them,” said Rush, who believes a more modular approach would serve the industry better. This doesn’t mean the car would become a transformer, changing shape and size at the push of a button, but it might mean that various modular components could be slotted in or easily removed, or that things like rowing machines or exercise bikes could be easily collapsed and tucked away into built-in compartments.

“If you buy a portable gym module, you aren’t always going to want your car to be a portable gym. Sometimes you’ll want to pack all your kids into it. So, the expansion and retraction of these modules will be important,” Rush explained. Modular components will also be a boon to the car accessory business, or could even provide an important upsell business model to car manufacturers themselves.

“What I’m most excited about is the personalization aspect,” said Vidikan. “If we assume that whoever owns the car fleet, or the car itself, is connected to your digital world, then the car can anticipate a lot about us and our daily needs, prior to us even stepping into it. The iPhone-ness of the car is already getting to be as important as the car-ness of the car, and we’re going to see that accelerate in the future, especially with the youngest consumers who might not even be of age yet. They will care a lot more about connectivity and personalization.”

Being able to do things in cars they might not have had time for prior to entering them, too, will be a game changer. People would be able to dress and get ready in their personalized pods. Women would be able to apply their makeup using any number of interior mirrored and possibly magnified screens. Fully stocked makeup and styling compartments could slide out when needed and retract as necessary. Families could eat together in their cars, around an actual dining room table, maybe spending some quality time catching up or maybe watching something on the myriad of screens that surround them. Vegging out as they eat their veggies, so to speak. “The type of modules that will be successful will be those that help people make the very best use of that time in the car,” said Rush.

Evolution Transportation and Business

Of course, people have been passengers since the invention of transport, the idea of having time to kill on a commute is not a new one. One might argue that passengers on buses, planes, and trains should all be used to sitting back and doing whatever it is they’d like to do to pass the time; however, the experience of being in one’s own private automated space, versus being in a more public, collective space is really quite different. Collective spaces still require a person to behave with a certain amount of decorum and abide by rules and regulations set by the carrier, whereby an autonomous car is an extension of one’s home, or room.

“It’s not about the technology, it’s about the psychology,” said Rockwell, adding that people will have more choices about what to do in their own space, even if they do end up doing many of the things they’d do on a long-haul flight, for instance. The difference would be the level of comfort and ability to take back some time in their day, shut down and not be overstimulated.

Others think passengers might relish the opportunity to connect with one another in shared carpool experiences. “Could the car become a place where you meet other people?” mused Vidikan, wondering whether the car might become a sort of “third space, much like sitting at a coffee shop, a bar or a park bench, where it’s not awkward to start talking to the person next to you. Maybe that’s even a preference when you order a ride in an autonomous vehicle: Do you want an experience that’s conversational or do you want peace and quiet?”

Ownership, Carpooling, and Leasing

Perhaps, in the age of autonomy, personal vehicles will have become passé. Maybe it will make more sense to car manufacturers to sell subscriptions to car services, where a person can lease any vehicle in a fleet to suit one’s needs on an ever-changing basis. Perhaps there will be different levels of subscription: Basic, premium, and luxury, which each come with their own module optionality and ability to customize and personalize the car’s interior. It’s feasible that fleets of vehicles ever-roaming the streets will be more convenient and more cost effective than outright ownership.

“The socio-economic aspect of full autonomy hasn’t been talked about enough,” claimed Vidikan, noting that those who may not be able to afford a car today

might soon have access to one whenever they need to go somewhere. Research shows that only 30 percent of commuters outside New York City have both their work and home locations within half a mile of a bus route, so the socio-economic significance of affordable carpool options that can drive anywhere is dramatic.

After all, transportation is not like healthcare; the state has no responsibility to ensure people can get to their jobs; that falls to individual responsibility. Public transport often falls short of being able to bring people to (or close enough to) places they need to go. Likewise, people who need jobs and don’t have transportation (and can’t afford it because they don’t have a job) are limited geographically to seeking jobs they can get to. With autonomous vehicles and car sharing fleets able to go anywhere, this problem gets solved.

“Ninety percent of people in the U.S. have smart phones, so they could hail a car from anywhere, easily.” Not needing to own a car, and being able to do more things in it, might also affect where people choose to live. “It will be interesting to see what it will do to commute times,” said Lindsay, explaining that people currently tend to not want to live more than an hour away from their workplace, as commutes can be stressful and isolating. In the age of autonomy—and at a time when employers are reeling back work-from-home privileges—autonomous vehicles could solve multiple problems on this front.

Airline and Hotel Industries

Once we can travel cross-country comfortably in autonomous vehicles, in our personalized pods with beds, screens, dinner tables, connectivity, and whatever

The Potential for New Freedoms

While better business class travel, quality commutes, and family road trips will all certainly be improved by the advent of autonomy, it’s for those with limited mobility that the promise of self-driving cars really comes into its own. Older people, for example, would regain access to the world, never having to be confined to their homes or senior centers anymore. Since driving licenses will be defunct in the age of autonomy, the age of car ownership could decrease dramatically, and an entire market of older people could also potentially present new market opportunities to manufacturers.

Others stand to gain freedoms as well: The physically handicapped, for example, might no longer be restricted to traveling with caregivers. Young children might be ferried to after-school activities without parents having to act as a taxi. In these cases, the cars could also provide detailed tracking functions, allowing loved ones to know where their aged parents or young children were just dropped off.

other creature comforts have been designed in, what becomes of the domestic airline industry, passenger rail, or even hotels for that matter?

The news cycle has not been kind to domestic airline carriers lately, and as conditions continue to deteriorate for economy passengers, people may decide that a 12-hour trip in comfort is preferable to enduring the many hassles of airline travel. Business travel, too, could be improved: With all the amenities of an office, and screens able to support increasingly life-like telepresence, perhaps a few days on the road, where one could make a number of stops and meet with customers cross country, might not be a terrible idea.

Hotels too may become defunct. Why pay the price of a hotel if your car has all the luxuries one might need? Well, maybe not all the comforts. Running water for showers might pose a challenge. Or would it? Enter the new “exclusive lounge” option for long distance travelers, tucked away in off-highway truck stops or easily accessible buildings. “You can imagine this network of cross-country stealth lounges set up in nondescript warehouses off to the side of the road, and you sign up to a subscription to use these lounges, much in the way you’d use a premium airline lounge” said Lindsay.

Car manufacturers could even sell the subscriptions to such lounges with the cars themselves, with basic, premium, and luxury status levels that access to progressively more exclusive roadside relay stations. Emerge from your car to stretch your legs at the lounge, and (based on your level of subscription) enjoy access to pools, fancy showers or spa facilities, fabulous food, and a fully equipped gym for a few hours before getting back in your car refreshed and ready for another full day on the road. No need to lose a whole night in a hotel. “The autonomous car is the ultimate new sleeper car, and you can travel in far more comfort door to door than the airlines currently make things” said Lindsay. “You don’t need a hotel anymore because you’ve just aggregated sleep to the list of functions you can do comfortably in your car.”

Conclusion

With autonomous driving becoming safer and more prevalent with every passing year, the age of the mobile living pod is fast approaching. Whether we choose to use our cars as extensions of the mobile workspace, or for more recreational uses, full autonomy is going to disrupt not just car mechanics, but also car interiors and overall design, as well as ownership models and rival industries in transportation.

Once we understand how to overcome things like nausea, the autonomous car really will become our oyster. ●



Solar Roads Pave the Way for a Connected Infrastructure

By Mouser Electronics

Drivers on Interstate-85 in rural Georgia may find themselves motoring over a stretch of solar pavement, one of the first to be installed in the United States. Solar roadways use *photovoltaic modules*—solar panels, like the ones found on rooftops—to capture sunlight and convert it into electricity. With goals of creating clean, sustainable energy to power lighting and signage, monitor road conditions, communicate with autonomous vehicles, and more, solar roadway technologies are indeed gaining momentum.

The solar technology deployed in Georgia comes from French company Wattway, which developed a system of solar panels that can be installed directly on a road's surface. Each panel includes **solar cells and sensors** inserted into a composite material that's just a few millimeters thick. The resulting photovoltaic pavers are then installed directly over existing pavement. What's more, the pavers are skid-resistant, adapt to thermal dilation, and are strong enough to support the weight of continuous traffic, including six-axle trucks. Wattway is conducting dozens of outdoor tests like the one in Georgia and says it hopes to commercialize the technology in 2018.

One of Wattway's largest installations to date is a test site in the French village of Tourouvre-au-Perche, a small Normandy village. The nearly 2,900m² of solar panels along the one-kilometer stretch of road generate 280kW of electricity at peak. By 2021, France plans to extend this project to stretch a whopping 1,000km, which could produce enough electricity to power all the public lighting in a town of 5,000 for a year.

Other companies are developing solar road solutions as well. A Dutch consortium constructed SolaRoad, the world's first bike path made from solar panels. The 72m stretch located in Krommenie, near Amsterdam, produced enough electricity in its first month to meet the electricity needs of a nearby residential home. SolaRoad consists of prefabricated panels of roadway topped with a tempered

glass surface. Under the glass, silicon solar cells collect solar energy that could power the road's lighting, traffic signals, and signage; send electricity to local households; and—someday—to power electric vehicles.

That's still in the future, with the broader idea of making solar roadways part of an increasingly connected, digitized, and electrified world. In this world, autonomous electric vehicles communicate with other vehicles and with nearby infrastructure like parking structures, traffic lights, emergency services, and so on. Meanwhile, early deployments are relatively small test projects to learn more about the technology and to learn how it stands up to the punishing effects of everyday traffic and all-season weather. But solar costs continue to drop, and that means photovoltaic panels can be affordably integrated into everyday materials. For example, Tesla Motors recently unveiled roof shingles that double as solar panels. Photovoltaic snowmelt systems, contact-free wireless vehicle charging, and photo-luminescent paint are some additional examples being prototyped and tested for solar roadway use.

Reliability and consistent performance are key requirements if the promise of solar roads is to be achieved. Just as solar roads require reliable components to meet the demanding requirements of solar energy production, transportation vehicles require robust and secure connections. For example, **Molex** designed and developed the **Mini50 Sealed Connectors** to support efficient, reliable, and flexible transportation interconnections. The Mini50 series now offers a sealed 4- and 10-circuit option, delivering 25 percent space savings over traditional sealed 0.64mm connectors, with smaller terminals to fit more low-current electrical circuits in sealed transportation-vehicle environments.

Mouser is proud to be a distributor for Molex electronics solutions that are helping to make solar energy a reality. Learn more about Mouser's commitment to innovation by visiting our **Empowering Innovation Together site.** ●



Vertical Farms Thrive With Help from Technology

By Paul Pickering for Mouser Electronics

Proponents of vertical farming paint a seductive picture: Fresh food without pesticides, increased production, reduced water consumption, use of vacant inner-city real estate, and more. Making this vision a reality requires precise control of light, temperature, water, and nutrients, and involves a wide range of **IoT technologies**, including **sensors**, **robotics**, and data analysis.

Vertical Farm Technology

Contrary to the pastoral vision of golden fields of wheat swaying gently in the breeze, the vertical farm is closer to a factory than a farm (**Figure 1**). The technology is changing quickly: Commercial vertical farms are capital-intensive, require millions of dollars of investment to get started, and there is stiff competition from greenhouses and other indoor farming operations.

Vertical farms use technology at every part of the farming process, ranging from nursery operations to harvesting, as **Figure 2** shows.

Large indoor growers use a wide range of automated devices, from automatic seeders to nursery robots that reposition pots. Since indoor agriculture is still a small market, few purpose-built pieces of equipment exist, so vertical farmers often adapt technologies from other industries.

Climate Control

Heating, ventilation, and air conditioning (HVAC) systems can help create the optimal growing environment by controlling temperature, humidity, carbon dioxide (CO₂) levels, air movement, and filtration. Plants grow quicker at higher CO₂ levels than the atmosphere's 400 parts per million (ppm): Tanks of CO₂ increase CO₂ levels in the vertical farm to around 1000 ppm.

Climate control systems run the gamut, from basic fans and heaters through to multi-functional control systems that incorporate the latest chiller, infrared, and UV sterilization technologies. The optimal system for any farm depends on several factors: Local regulations, farm size, type and locations, crop types, and, of course, budget. In selecting a system, there's often a tradeoff between capital expenditure (CapEx) and operational expenditure (OpEx): More expensive systems tend to be more efficient and have lower operating costs.

Lighting

Compared to the traditional farm that gets free energy from the sun, the vertical farm uses artificial light to promote faster growth, and the cost of energy is one of the largest line items on the budget.

Many vertical farms have traditionally used fluorescent lights; these are relatively cheap to buy, but **LED lights**, with their greater efficiency, consume about 60 percent less power for the same output. LEDs have technical advantages, too: Their light levels can be precisely controlled, and because they don't emit much IR radiation (heat), they can be placed close to the plants for best light absorption. LEDs can also create the best combination of light spectrum and intensity that gives the most energy-efficient photosynthesis for each plant species.

Mirai in Japan, for example, uses 17,500 LED bulbs that provide the exact wavelengths that various crops need to thrive. According to the company, the new system has reduced power consumption by 40 percent and increased yields by 50 percent.

Longer term, researchers expect that organic LEDs (OLEDs), which use a film of organic compounds



to generate light, will eventually become a more economical and efficient option.

Monitoring and Control

The vertical farm is a closed environment, and farmers take strict steps to eliminate pests, pollen, or viruses. The precautions apply to humans, too: Before entering Mirai's "Green Room," workers must take hot showers, wash with shampoo and body soap, and change into sterilized work clothes.

Vertical farms don't use soil as a growing medium to transfer nutrients to plant roots: Instead they use

- **Hydroponics**, in which plants are grown in a nutrient-rich basin of water, or
- **Aeroponics**, where crops' roots are periodically sprayed with a mist containing water and nutrients

For both methods, operators continually monitor all the macro- and micronutrients being supplied to the plants (**Figure 3**). Unlike a conventional operation, the water that evaporates from the plants into the atmosphere



Figure 1 (top): A vertical farm uses technology in a factory-like setting to ensure products of consistent quality. (Source: Mirai)

Figure 2 (bottom): Technology can help improve every stage of the indoor farming process. (Source: Newbean Capital/ Local Roots)

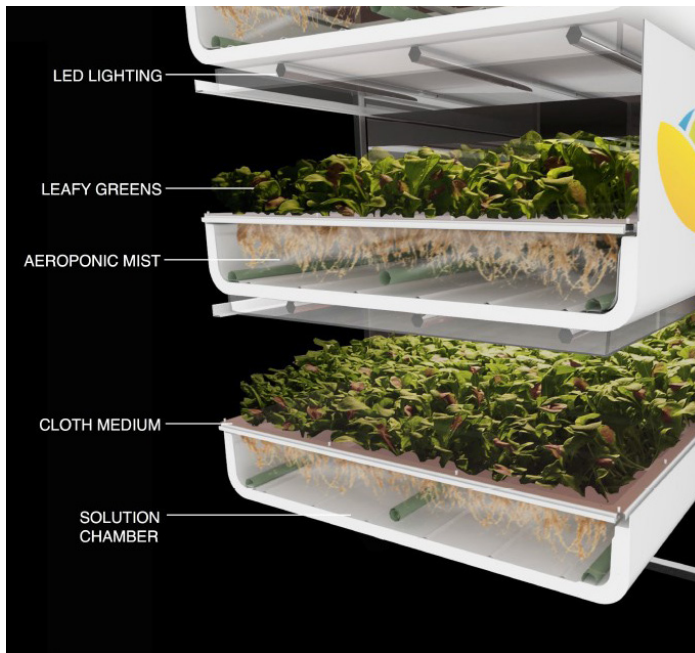

Figure 3: Vertical farms control every aspect of the growing process, from the placement of the lights to the nutrients applied to the roots. (Source: Aerofarms)

isn't lost; air conditioners recover up to 98 percent of water in a vertical farm.

The result of the tight monitoring and control is that a vertical farm doesn't use pesticides, herbicides, or fungicides; the harvest can be ready in as little as 18 days, half the time of a conventional farm. Vertically farmed crops can contain considerably more vitamins and minerals than conventional produce: Mirai claims that their lettuce has up to ten times more beta-carotene and twice the vitamin C, calcium and magnesium of a standard product. In addition, no rinsing is needed and up to 95 percent is useful in cooking, compared to the usual 60 percent.

Robots

What is the next stage of vertical farming? Ruthless cost reduction and even less human involvement, so robots and drones are increasingly used. In Kyoto, Japan, SPREAD has just broken ground on its new "Techno Farm," a 47,000SF, \$175 million dollar factory that's slated to produce 30,000 head of lettuce a day when it's complete in 2018.

The farm will use robots that resemble "conveyer belts with arms," according to *TechInsider*, to plant seeds, water and trim plants, and harvest them. Compared to SPREAD's existing Kameoka plant factory, the Techno Farm will cut labor costs by 50 percent and energy costs by 30 percent.

Drones will reduce the number of human operators to monitor large areas. Suppliers to the industry are introducing lightweight drones that are suitable for monitoring crop conditions in large-scale indoor farms: Intel®, for example, offers its **Aero Drone**, an unmanned aerial vehicle (UAV) development platform that includes a wireless controller and the Intel® **RealSense™** camera.

The Role of Big Data

In conventional farming, data analytics provides farmers with both current and historical data on their crops. The information comes directly (from instrumented fields and equipment) and indirectly (via satellites and GPS tracking systems). Data metrics include soil quality and moisture, rainfall accumulation, fertilizer and pesticide levels, and crop yields.

State-of-the-art vertical farms view data collection and analysis as a key element in their business model, employing as many data scientists and engineers as they do agronomists and plant biologists. Aerofarms, for example, collects more than 10,000 measurements during a single growing cycle; the company uses this data to boost yields and quality, as well as to drive down costs towards the point that the vertical farm can be competitive with the best conventional methods.

Conclusion

The vertical farm makes extensive use of technology to grow plants in a factory environment. Just as on a traditional production line, workers and managers monitor and control every aspect of the crop to maximize yields and ensure consistent quality. The data gathered helps improve quality in future generations of "products."

For more information about electronics in vertical farms, visit [Mouser's Shaping Smarter Cities website](#). ●



Conquering Vertigo: MEMs in Augmented Reality

By Paul Golata, Mouser Electronics



I grew up in Chicago. It is my home town, and my parents still live there in the same house. Yes, I still cheer on the Chicago Cubs, believe Chicago-style pizza is the only kind worth eating, and think the Chicago skyline is the most beautiful in the world.

Recently, I went back home and attended a conference in the Chicago area where I was a speaker. Add the fact that my wife is a fifth-grade school teacher who has her summers off, I decided to take her with me for this trip. I told her that after my conference we would spend some time seeing the sights of Chicago.

One of the things she wanted to do was to go to the Skydeck deck at Willis Tower, a large skyscraper in Chicago. This building is the tallest building in the Western Hemisphere (442m), with the Skydeck is on the 103rd floor (412m). The Skydeck is unique in that it has several plexiglass boxes on the west side of the building that extend out 1.3m from the face of the building, daring visitors to step out and experience the feeling of standing suspended 103 floors over Wacker Driver and the Chicago River.

Being on the Skydeck is enough to make one experience vertigo—that odd sensation of feeling off-balance, dizzy, and like your head is spinning. When you experience vertigo, it makes the world seem like it is swaying and out of kilter, drifting to one direction or another as if you are being pulled away and down from what is your normal upright orientation. Fortunately, I did not experience any symptoms of vertigo during our time on the Skydeck, despite the dizzying view (**Figure 1**).

This made me glad because I had been suffering the effects of vertigo since December of this past year. It came on suddenly one day and stayed with me in various forms for about four to five months. It



Figure 1: Looking down through the plexiglass box floor to the street below (Wacker) on the Skydeck at Willis Tower, Chicago. (Source: Paul Golata)

prohibited me from doing normal activities such as running and biking that I have always been involved in.

I got rid of vertigo by simply taking it easy and letting time heal my body's issue.

Some technological developments promise many benefits, but like tall buildings, might also induce a case of vertigo. Augmented Reality (AR) projects computer-generated images and superimposes them into the user's field of view (FOV), altering the real world and creating an enhanced visual sensory interface. Depending on the speed and contents of the additional visual stimuli, the potential exists for the mind to feel a case of vertigo. If AR is ever to become a popular tool for everyday use to aid people in their accomplishment of tasks, then design engineers must ensure that this psychophysical reaction is avoided by using motion sensors and finely designed circuits to provide a visually stabilized platform for the mind to experience.

Fortunately, there is a solution. One that has been developed by electronic design engineers to address this problem and many other related positional and orientation issues is **MEMS technology**. Micro-electrical mechanical systems technology uses extremely small **sensors** that incorporate an electromechanical structure and the supporting analog circuitry for conditioning signals obtained from the sensing element.

Recognized leaders in high-performance analog electronic components, including **Analog Devices**, are developing sensors to ensure that vertigo is never an issue in AR technologies. Analog Devices combines products, including data converters, amplifiers and linear

products, radio frequency (RF) ICs, power management products with their sensors based on MEMS technology, to enable AR headsets to perform so that human dizziness is prevented by their dedication to solving the toughest engineering challenges. Analog Devices' MEMS product portfolio includes accelerometers used to sense acceleration, gyroscopes—to sense rotation, and inertial measurement units employed to sense multiple degrees of freedom combining multiple sensing types along multiple axes.

One way these individual MEMS products are made to work together easily so that AR does not result in vertigo is through **Analog Devices iSensor® MEMS inertial measurement unit (IMU) sensors**. This unique design employs multi-axis combinations of the previously mentioned precision gyroscopes, accelerometers, magnetometers, and pressure sensors. The IMU effectively senses and processes multiple degrees of freedom, even in highly complex applications and under dynamic conditions. These plug-and-play solutions offer full factory calibration, embedded compensation and sensor processing, plus a simple programmable interface.

Take as a specific example the new **ADIS16460 iSensor® MEMS IMU** device. It is a complete inertial system that includes a tri-axial gyroscope and a tri-axial accelerometer. Each sensor in the ADIS16460 combines industry leading iMEMS® technology with signal conditioning that optimizes dynamic performance. It provides a simple, cost effective method for integrating accurate, multi-axis inertial sensing into industrial systems, especially when compared with the complexity and investment associated with discrete designs. All necessary motion testing and calibration are part of the production process at the factory, greatly reducing system integration time. Tight orthogonal alignment simplifies inertial frame alignment in navigation systems. The SPI and register structures provide a simple interface for data collection and configuration control.

The time is now to move forward and capture new ground in your Augmented Reality designs. Conquer any case of vertigo you might be feeling and ascend to new heights. Designing with MEMS and IMUs make it so that the only heads that will be swimming is your bosses—when he finally realizes how your designs conquer new pinnacles. ●

BEST of Methods eZine

With Foreword by Steve Hegenderfer, Director of Developer Programs at the Bluetooth SIG



Contents

- In What Ways Does Bluetooth 5 Enable Design Engineers to Pioneer Innovative Solutions?
- A Look Back and Ahead at Bluetooth
- Case Study: Bluetooth 5 Automatic Parking Meter System Eases Parking Headaches for Cities and Drivers Alike
- Bluetooth 5 Mesh Networking
- Q&A With Industry Leaders: The Potential of Bluetooth 5 for Design Engineers
- Answering Important Questions About Bluetooth 5



Best of 2017 Projects

Mouser's engineers and technical content team developed a number of **great projects** in 2017! Some favorites include one focusing on smart buildings, programmable garden lighting, and a magic wand for Halloween. We add projects regularly to our **Open Source Hardware** section (Projects tab) on the **Application and Technology website**.

Check out this smart porch light with Digi LTE XBee by our resident project engineer, Joseph Downing.

Smart Porch Light Project: Digi's XBee LTE Cellular Module And Arduino Mega-2560 Shine Together

By Joseph Downing, Mouser Electronics

The Internet of Things (IoT) allows us to connect, control, and visualize data from any number of sources. We can create interactions, check sensor statuses, and receive notifications whenever certain events have occurred. With the increasing popularity of cellular communication and its availability, the possibilities for IoT solutions grow substantially. Network access from virtually anywhere in the world opens up the door to ideas that before now might have seemed impossible.

For this project, we have combined **Digi International's** Cellular LTE XBEE module with an Arduino Mega-2560 to give us access to a cellular network for use with an automated porch light. This demonstration uses several different sensors mounted in the porch light housing, including those to measure ambient light, temperature, humidity, and ultraviolet (UV) light, along with a relay used for control. When used with the provided code and a cloud service such as Ubidots or Google Cloud Platform to store and read your data, the result is a smart light that can provide the user with sensors' measurements viewable instantly anywhere network access is available (**Figure 1**).

The method for communicating the information you've gathered is just as important as the devices you've chosen. Several options are available such

as MQTT API and REST API for transferring your data to your selected cloud service. Your choice will be dependent on a number of factors including power requirements, connectivity, bandwidth availability, and your service. Each option is better suited to some scenarios over others, so spending some time researching your options will be beneficial. For our purposes, we have chosen REST API as outlined further along in the project. Plenty of resources are available on the web for those interested in further understanding each.

In the following sections, we'll provide links and resources needed to complete the project, as well as show you how to set up the XBee module and shield, the different sensor modules, and program the Arduino Mega.

Step 1: Gathering The Devices

Ideally, the information and provided links should be sufficient for anyone to build a cellular IoT sensor node. The project is intended for those who have familiarity with the Arduino development platform and some experience in programming.

For this project, you will need the devices outlined in the [Mouser XBee Cellular Project BOM](#), which includes:

- The XBee Cellular kit with LTE Module and an interface board
- The Arduino Mega with suggested power supply
- The sensors and interface shield outlined in the overview
- An account with Ubidots Cloud Service at <https://ubidots.com>

Optionally you may wish to purchase a UART communication cable not included in the project BOM:

- [895-TTL-232R-RPI](#)

Of course, as with any project, other components can be used depending on need. Digi International has several additional cellular modules available for you to choose from based on your project requirements:



- [Digi International XBee® Cellular 3G Global Embedded Modem](#)
- [Digi International XBee® Cellular LTE-M Embedded Modem](#)
- [Digi International XBee® Cellular NB-IoT Embedded Modem](#)

The example software for the Arduino Mega-2560 is stored on GitHub ([Mouser XBee Cellular GitHub Repository](#)). This will require the installation of the Arduino IDE to interface and upload the code to the Arduino Mega. You can download the IDE using the following link: [Arduino IDE Software](#). You will need to ensure you have installed any required libraries that may not be included with the IDE such as the Temp/Humidity sensor library ([Seeed Studio Temp/Humidity Library](#)). If this is your first time installing third party libraries in the IDE, please refer to the Arduino tutorial linked here ([Arduino Library Guide](#)).

Step 2: Setting Up The Digi XBee Module

The XBee module can be set up easily using the XCTU software offered by Digi International. The kit for the LTE module provides you with a development



Figure 1: Mock house and porch light with integrated sensors.

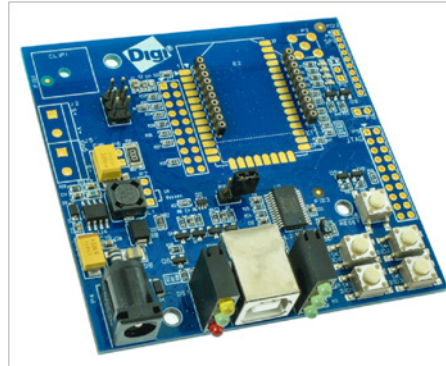

Figure 2a: The Digi XBee development base.

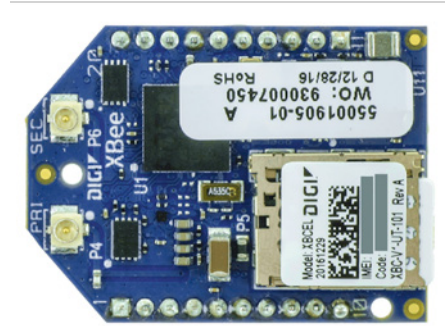

Figure 2b: The Digi XBee LTE Module.

base that will allow the XCTU software to interface and change the module settings (**Figures 2a and 2b**). To connect to your cloud service, you will need to make several setting changes as well as a possible firmware update. If you do not currently have the software installed, you can find and download it using this link ([Digi XCTU Software Link](#)). Each XBee module will come activated with 6 months of free cellular service through Verizon. Though we have not had an opportunity to use any of the other available Digi Cellular modules, the setup process for each should, in theory, be identical.

Adding The XBee Module

The first time you open the XCTU software, you will need to add the XBee module from the Radio Module List on the left side of the screen by clicking the module outline with the (+). A pop up will ask for the correct COM port which can be verified in your system's device manager. Once

you review the COM settings and select OK, the software will scan for available devices. Select the correct device from the list on the left and click "read" to import the current settings from the module as shown in **Figure 3**. If the device firmware needs updating, you may need to perform this action at this time.

Configuring The XBee Module

For the module to connect and send data to the Internet, you must configure it for TCP mode, update the destination address with the IP or web address of your cloud service, and set your destination port. In most cases, the destination port will be 80 and need conversion to the hex value 50. If this is not the correct port, verify and update it with the one needed by your selected cloud service remembering to convert first. Once you have made all the proper changes, refresh the device by clicking the write icon at the top of the software screen. Once the module is configured, remove

it from the development board and insert it carefully into the XBee shield, paying attention to polarity.

For additional information or specific instructions on how to connect and modify the LTE module, or use of the XCTU software, please refer to the following links ([Digi XBee® Cellular LTE Cat 1 Documentation](#)) and ([XCTU Configuration and Test Utility Software Documentation](#)). To make things easier we have also included a configuration file for the XBee module on the project GitHub page you can use to import pre-configured settings to the module.

Setting Up The Sensor Shield

In addition to the XBee shield, you will also use the Seed Studio Base Shield (**Figure 4**) that allows easy plug-in of multiple sensor modules. Before continuing, ensure that the switch on the shield is set to 5V for proper function. Attach the five devices,

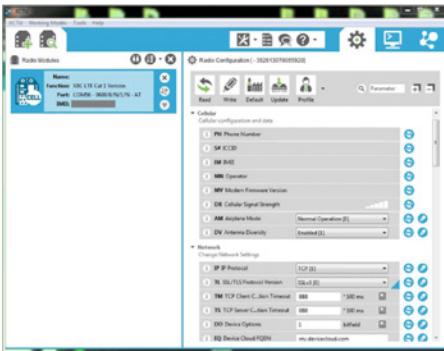

Figure 3: Using the XCTU dialog box, you'll add the XBee module by clicking the plus sign (+).

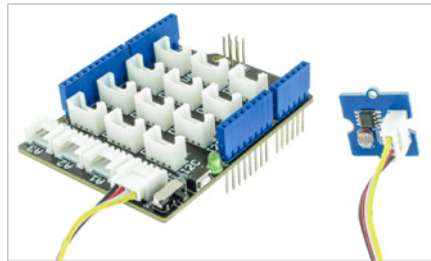

Figure 4: Sensor shield with ambient light sensor in port A0.

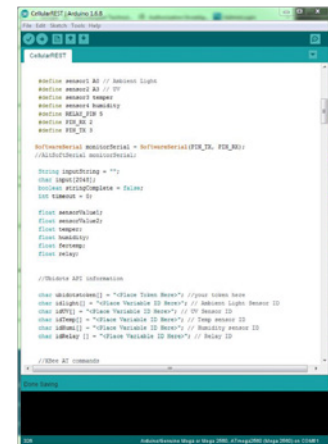

Figure 5: Arduino IDE.

the temperature/humidity to the I2C, ambient light and UV to the analog, and relay to the digital.

It is important to note which analog and digital ports you are using since they will need updating in the provided Arduino code to match. The I2C connection will work regardless of which I2C port is used. Once you have completed assembly of the shield, plug the base shield into the Arduino.

Step 3: Setting Up The Arduino Code/REST API

The provided Arduino code uses RESTful or REST API to communicate over HTTP to post or get data from the cloud. For this example, we will be using Ubidots as our cloud service. Data from the sensors is communicated over a serial port from the Arduino to the XBee, which is then transmitted over the cellular network. The Arduino Mega-2560 has only one available serial port to interface with the XBee shield and may need the creation of a second virtual port using the SoftwareSerial function in the

Arduino code. This is not required for the code to function but does make visualization through a serial monitor easier if you want to check progress.

The program begins by issuing a series of AT commands to the XBee module to verify the correct configuration and connection to the cell network. Once the program confirms a network connection, it will send a generic POST to the cloud service to verify communication. If successful, the server will return with a response such as 200 or 201, which will be output to the SoftwareSerial port seen in **Figure 6**. Data is transmitted and received through the Serial function and displayed using the MonitorSerial configured through the SoftwareSerial mentioned previously and shown in Figure 6. Data from the sensors is uploaded as the software cycles through each sensor function call on a 5-second delay to give enough time for a response from the server.

As previously said, you need to make changes to the code for

the software to perform correctly. Some may not be necessary, but things such as changing the API token and Variable IDs will be required. Depending on how you chose to configure the sensor shield or which pins you identify on the XBee shield for the RX and TX lines, it is important to update these prior to uploading your code to the Mega.

Step 4: Setting Up The Ubidots Dashboard

This example uses cloud services offered by Ubidots for data storage as well as dashboard creation as shown in **Figure 7**. If you have not used the service prior, you will need to create an account with them. The service uses a point-based system which I have found for those starting out to be very user-friendly and offers many tutorials and guides to aid in setup for several different development platforms. Create your account, giving all required information, and take time to read the documentation tab that talks about REST and MQTT as well as

Best of Mouser's Blog: *Bench Talk* for *Design Engineers*

Mouser's blog, called *Bench Talk for Design Engineers*, expanded quite a bit this year! Written by engineers and other subject matter experts, Bench Talk covered a variety of topics that complement our technical articles and ezines, discuss engineering-related topics in the news, and include lighter topics and pieces as well.

Some key topics from 2017 include soft robotics, virtual reality, augmented reality, FPGAs, LEDs, hardware startups, engineering for space, pneumatic engines, USB 3.2, Movidius, sensors in wind turbines, Bluetooth BlueBorne, I3C, dropsondes, drones, containers, autonomous vehicles, Industry 4.0, agricultural sensors, mesh networking, thermal management, cybersecurity, millimeter wavelengths, hearables, and much, much more!

We added new categories as well, including **Student Central**, which aims to provide university engineering students with resources for learning, expert advice for landing internships and jobs, and other topics.

If you haven't already, check out *Bench Talk for Design Engineers!* We've included just a small sampling in this ezine.



Your Microwave Oven May Soon Become Obsolete

By Barry Manz for Mouser Electronics

Magnetrons have powered microwave ovens since Percy Spencer accidentally invented them at Raytheon in 1945. We take these appliances for granted even though they can't do much more than heat coffee, explode popcorn kernels, heat up premade meals, and defrost foods. That's about to change, if not immediately, then certainly in the next five years, as microwave ovens become true *cooking* appliances, as RF power transistors replace the magnetrons as their RF power source.

Magnetrons have never been an ideal solution for powering microwave ovens. They operate at a single frequency that can drift over time. Their RF output power can't be varied so a microwave oven is either "on" or "off," which makes it impossible to optimize cooking performance. A magnetron's output power also declines with use, which isn't a concern for consumers, but a huge issue for fast-food restaurants and other companies that use them almost continuously, requiring magnetron replacement at regular intervals.

That said, without magnetrons microwave ovens might never have become a commercial product at a price consumers could afford. They're cheap and basically get the job done and anyway. Solid-state devices couldn't produce enough

power, were too fragile to withstand big changes in impedance, and cost too much, so they weren't an option. But RF power transistors have come a long way, and the limitations that kept them from consideration have disappeared.

This presents interesting opportunities and the potential to create an entirely new type of kitchen appliance. It would combine the flexibility of solid-state power with digital signal processing and other techniques to transform the microwave oven into a full-fledged cooking appliance. White-goods manufacturers have taken notice.

Once these new appliances come to market, they'll be able to cook several different kinds of food simultaneously, each one to exactly the right amount of "doneness" while retaining moisture and nutrients, which current microwave ovens don't do very well. They'll also eliminate the need to open a hot oven and poke foods with a thermometer to check their temperature: Thanks to the use of sensors, the oven will "know" when they're done. **Figure 1** shows a solid-state cooking appliance concept from NXP Semiconductors.

They'll also be able to defrost foods far better than magnetron-powered



Figure 1: The Sage solid-state cooking appliance concept demonstrated by Freescale Semiconductor (now NXP Semiconductors) shows a complete cooked meal. (Source: NXP Semiconductors)

ovens, which if you've use one to thaw a steak you've certainly experienced that some parts are thawed, other parts are cooked, and the rest is somewhere in between. The appliances will come with recipes that can be selected by a smartphone app and sent to the oven. Basically, all you do is press "start" and you're done. No doubt the number of recipes will grow rapidly.

However, solid-state devices represent a new frontier and one that appliance manufacturers aren't familiar with, which is

precisely the situation that the RF Energy Alliance is helping to change. Since it was founded in 2014, the alliance has tripled its membership, and its members now include white goods goliaths like Whirlpool, Panasonic, and Miele, RF and microwave component manufacturers, and Worcester Polytechnic Institute.

In addition, manufacturers of RF power transistors such as **NXP Semiconductors** and most recently MACOM have designed devices dedicated to solid-state cooking. NXP has also worked with

companies such as Goji Cooking Solutions, which developed the first commercially-available "software-defined" RF cooking appliance, and NXP has reference designs and other design tools to help OEMs build these new appliances.

Solid-state cooking may sound mouth-watering but don't expect to find these appliances for sale during this year's holiday season as they're not fully cooked yet. They're more than a design concept, though, and manufacturers simply need time to perfect them before releasing them into the commercial market. ●



Industrial Automation

By Marcel Consée, Mouser Electronics

While the term, Internet of Things (IoT) first turned up in 1985 (when the Internet as we know it today was not even a prospect yet), the need for an “industrial” subset has been recognized only in the early 2000s. Today, Industrial IoT is being implemented far more rapid than a more generic IoT, and—believe it or not—the key drivers for that came out of Europe.

When the term “Industry 4.0” (Industrie 4.0) was coined back in 2011 at the Hannover Messe, the initiative was widely viewed as a buzzword creation project. Even more so, since Networking had become a key issue in industrial automation in the 1990s. Furthermore, a “high-tech strategy” launched by the German government didn’t seem to be something that had to be taken seriously.

We will probably never know how much of its success was due to thorough planning and how much was sheer luck, but... well, it worked. Obviously, there was a need in Germany’s manufacturing industries for guidelines regarding this issue, and thanks to their global ecosystems of suppliers and subcontractors, the concepts spread to many parts of the world.

Similar activities in other key regions—e.g., “Industrie du futur” in France, I4.0 in Japan, China’s 2015 five-year plan or the IIC in the USA, most of

them incorporated the Industry 4.0 approach—have turned the “Industrial Internet of Things” (IIoT) from concept to reality in a short time. Not as a subset of a general IoT, as used to be predicted, but as the pioneering technology. In fact, IIoT is actually here while IoT is still more of an idea.

France’s Industrie du futur has been conceived in close cooperation between French and German industry associations, accompanied by both governments and the European commission, and became a model for Italy’s strategy “Fabbrica Intelligente,” Spain’s “Industria Conectada 4.0” and, more general, an EU-wide incentive for industrial digitization.

Actually, this approach is recognized worldwide as a locational advantage for the European Manufacturing Industries. The USA and China joined the effort of standardizing industrial digitization only in 2014/2015. The Industrial Internet Consortium IIC as well as China’s tech strategy in its five-year plan are very closely related to the European specifications. Obviously, the organizations have learned from mistakes of the past and are trying to avoid proprietary solutions.

Connecting Robots

From a technical point of view, the interesting parts of Industry 4.0 are

not the “cyberphysical systems”— industrial robots and PLCs have been around for decades. What matters is the connectivity.

The major changes in connections between automation equipment have actually happened in the late 1990s/early 2000s, when many more or less proprietary fieldbus solutions became obsolete. Ethernet connections expanded from the administrative areas into factory floors, which opened up the automation market. However, fieldbusses were there for a reason: Ethernet couldn't cope with real-time requirements; it just was not

designed for predictability. Nevertheless, the trend toward simpler, more standardized connections turned out to be unstoppable, and so Ethernet and fieldbus features were combined. Specialized industrial protocols and topologies include Profinet, EtherNet/IP, SafetyNET, SERCOS, and EtherCAT.

For the sake of interoperability, Ethernet standard connectors are in use everywhere today, even if they come in ruggedized housings and multiple formfactors.

With the propagation of wireless connectivity, industrial robots are

becoming more mobile. Many of the protocols mentioned work also with Wireless LAN, even though other transmission protocols and standards like LoRa, ZigBee, or Industrial Bluetooth profiles are gaining foothold. However, most players in the manufacturing industries are aware of the danger that comes with the introduction of new, “smaller” communication standards. After all the trouble the industries went to when standardizing wired industrial communications, hardly anyone wants to risk a new fragmentation of the market on the wireless side. ●



Design Principles of Industry 4.0

Interoperability: The ability of machines, devices, sensors, and people to connect and communicate with each other via the Internet of Things (IoT) or the Internet of People (IoP).

Information transparency: The ability of information systems to create a virtual copy of the physical world by enriching digital plant models with sensor data. This requires the aggregation of raw sensor data to higher-value context information.

Technical assistance: First, the ability of assistance systems to support humans by aggregating and visualizing information comprehensibly for making informed decisions and solving urgent problems on short notice. Second, the ability of cyber physical systems to physically support humans by conducting a range of tasks that are unpleasant, too exhausting, or unsafe for their human co-workers.

Decentralized decisions: The ability of cyber physical systems to make decisions on their own and to perform their tasks as autonomously as possible. Only in the case of exceptions, interferences, or conflicting goals are tasks delegated to a higher level.



Piezoelectric Motor Provides Precise Motion Without Magnetics, Gears

By Bill Schweber for Mouser Electronics

The piezoelectric motor is a little-known but widely-used alternative to the magnetic motor that offers precision and small-force motion.

Motors, Motor Control, Magnetic Motor, Piezoelectric Effect, Piezo Motor, Motor Driver, Capacitive Load

When most engineers hear “motor,” they usually think “magnetics.” That makes sense because traditional motors use coils, windings, and magnetic materials to provide rotary or linear motion. Whether an AC or DC motor, brushed or brushless, stepper, or other configuration (see [The Mystery and Magic of Motor Genealogy](#)), the interaction between magnetic fields and materials converts electrical energy into mechanical motion.

So, when the time comes to implement small-scale and precise motion, designers often first consider a very small motor or even a small motor plus gearset. However, at these smaller scales, magnetic motors are difficult to control and still relatively large, while gearsets bring more issues of size, weight, cost, mechanical play, backlash, and wear. Even with advanced motion-control electronics and software, it can be a tricky and unsatisfactory solution.

But there exists an alternative to the magnetics-based motors

currently in widespread use: The *piezoelectric motor*, also called a *piezoelectric actuator*. Its principles of operation leverage the well-known piezoelectric effect. Engineers are familiar with this two-way phenomenon and its many applications, such as converting vibration into electricity for energy harvesting, building pressure-sensing transducers, and implementing spark ignitors, to cite just a few examples. In the complementary mode, the effect is used for transforming electrical energy into pressure and motion, in audio signaling devices/annunciators and, of course, as the core of ubiquitous crystal oscillators.

The piezo motor is built of a single ceramic crystal or as stacked layers of these ceramic materials. When an electric field is applied across the assembly via a voltage, the material deforms, as seen in **Figure 1**. In the most-common design, the elongation is restricted to a single plane of motion. The material is directed by on/off voltage pulsing and mechanical arrangement to

make a series of stretches and position holds, and so moves like a caterpillar (sometimes also called an “inchworm” design).

The motion is both minute and precise. Piezo-based motors are used in nanoliter infusion pumps and optical-position mechanisms. These motors can provide positioning down to nanometer tolerances, with step rates into the MHz range—clearly an impossible specification for a magnetic-motor approach. Available force is in the order of nanonewtons to about one newton (though special ones are made that reach hundreds of newtons) and motor weight for small ones is in the less than-10-grams range.

These are generally not “high-power” engines, but they don’t need to be in the target applications. Also, the non-magnetic nature of piezo motors is a benefit and even a necessity in some situations. Piezo motors can be operated as open-loop transducers or used as a strain gauge in a feedback loop for the additional precision that closed-loop control offers.

Not only are the fundamental physics of the piezo motor very different from that of a magnetic motor, the drive requirements are also different. A magnetic-based motor is a current-driven device, as magnetic fields and strengths are a function of current through the windings (while there is voltage, of course, that is used to drive the current into the windings; the motor equations are all based on the interplay between current and magnetism).

The piezo-based motor is a voltage-driven scenario. The piezo material needs an electric field that is

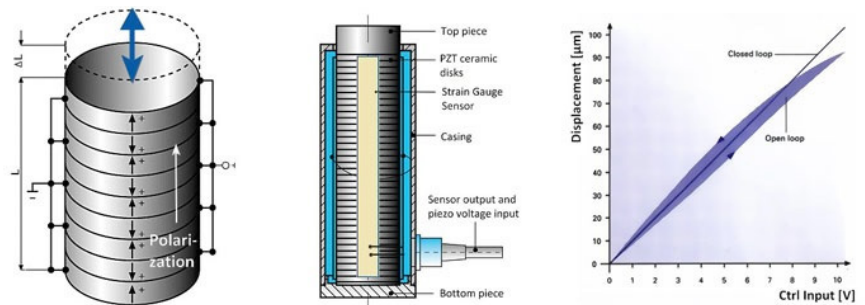

Figure 8: *The piezoelectric motor is usually made of stacked piezo elements and is stimulated by an applied voltage (left). Some units also include a strain gauge for closed-loop control (center) that enables even more-precise control of applied voltage versus displacement (right). (Source: Physik Instrumente GmbH & Co.)*

supplied by a voltage differential across the material. Depending on the size of the motor, this voltage can be as low as 50V or as high as a thousand volts or more (simple piezo buzzers and vibrators typically require only about 25–30V).

This places several challenges on the design of the drive electronics:

- Because of the potentially lethal voltages, use of appropriate insulation and wire routing are critical, as well as attention to creep and clearance requirements as set by regulatory bodies.
- Unlike the MOSFET/IGBT switches used to control the flow of current in a magnetic motor, piezo motors are usually driven by high-voltage, low-current amplifiers (either standard op amps boosted by high-voltage transistors on their outputs or application-specific high-voltage op amps).
- The magnetic motor is a highly inductive load, so the drive circuitry must handle current inrush, inductive kicks, and other inductive-load attributes. In contrast,

the piezo motor is highly capacitive, so the driver op amp must be capable of providing the needed voltage into loads of 1,000 picofarads or more yet remain stable, which requires a special output-stage design even if the op amp can easily deliver the high voltage.

The widespread use of piezo-based, non-magnetic motors shows how clever engineers have adapted basic materials and physics principles to create innovative solutions to micro-motion applications. The next step in motion and motion control is developing practical MEMS-based motors too small to see with the unaided eye, for uses such as “pumping” individual cells through a micro-capillary path in a medical test instrument—lots of R&D work is already underway on those.

For more information about piezo motors, visit the “[The Mystery and Magic of Motor Genealogy](#)” in Mouser’s [Bench Talk](#) blog, as well as the article called “[Basics of MOSFETs and IGBTs for Motor Control](#),” located in Mouser’s [Application and Technology](#) site. ●



Engineering Career Fairs: Yeah, You Gotta Talk About Yourself

By Deborah S. Ray, Mouser Electronics

If you're like many engineering students, you probably find the idea of attending a career fair to be bit nerve-racking. Most of us would probably prefer just to lurk at the career fair and land an internship based on our resumes and professor recommendations and maybe a bit of osmosis. I'm getting a pit in my stomach just thinking about my own experiences, and that was 20-mumble years ago!

Why do career fairs create so much angst? While we could go on about them being an important resource for landing the internship you want, marking your professional entry into your field of study, and having too much commotion to really engage in meaningful discourse, the real reason is simpler: Not all of us are comfortable talking about ourselves—much less selling ourselves.

So how do you figure out what to talk about? The good news is that *listening* to what potential employers seek will provide the best clues to help you know what to say. They are seeking information about you, but ideally what you share about your projects and coursework will be in the context of their needs. Beyond that, a little planning and practice go a long way in presenting yourself as articulate and cogent,

easing those sweaty palms, and standing out as a candidate. Let's take a look....

Research Participating Companies

Before the fair, take time to research participating companies, understand what they do, and get an idea of how engineering fits into their business. Basically, learn as much as you can before you go. Why? Part of it is simply showing that you've done your research, which gives you an advantage over those who don't. Perhaps more importantly, this gives you some background information that helps break the ice when chatting with their representatives. Rather than arriving and asking, "What do you do?" you can arrive saying, "I understand your company does XYZ" or "I'd like to know more about the XYZ industry." (It also provides useful details for your "elevator pitch," discussed next.)

A good starting place for research is the career fair website, which usually lists the participating companies and sometimes internship details as well. If possible, take time to visit the websites for all the participating companies and identify where your interests and goals align. It's tempting to explore just ones with name recognition or ones with best internship reputations,

but it's a good idea to do at least cursory research on all participating companies because you might miss opportunities that would be an unexpectedly great fit. Exploring all the companies is also a good way to learn more about what engineers in your area do, the types of applications they work on, and the types of problems they solve.

From that initial research, identify the top five or six companies that best align with your interests and goals, then explore not just what they do, but how they do it, who they hire, and what people say. Visit those companies' websites, as well as their microsites on GlassDoor and LinkedIn, which can help you gauge corporate culture and reputation. This part does take some time, but it provides useful insights, as well as gives you potential talking points at the fair.

Practice Your Elevator Pitch

Imagine you're standing in an elevator and someone asks you about what you do professionally: While the elevator takes you from the coffee cart on the first floor to your office on the 22nd floor, you'd have ~15 seconds or so to answer the question. An "elevator pitch" is a type of communication aimed at providing key details in a short amount of time. In the job fair context, you'll use an elevator pitch when you introduce yourself to prospective employers or to reply when someone asks, "Tell me about yourself." You'll encounter both at a job fair.

I can hear you groaning as you read this. Many people, even



seasoned professionals, find introducing themselves and starting conversations especially difficult. That's why coming up with—and practicing—your elevator pitch is important. For most traditional students, an elevator pitch would be two or three sentences that communicate things like where you are in the program, your interest areas, and your senior project topic, among other possibilities, like this example:

"Hi, I'm Jane Smith. I'm a senior in electrical engineering with a particular interest in aerospace applications. I completed drone certification this summer and am starting on my senior project now—testing jamming and spoofing drones for military applications."

In this example, the student has relevant experience and a good idea of what she's interested in.

And because she offers some specifics, she's giving the hiring manager some fodder to ask questions, which then helps discussions flow.

If you're not yet far along in your coursework, just say so:

"Hi, I'm Jane Smith. I'm a second-semester freshman interested in electrical engineering. I'm here to learn more about what electrical engineers do at various companies."

In this example, Jane sets the expectation that she's not yet seeking an internship, yet demonstrates that she's proactive.

Better yet, use the company research you did before the career fair in your elevator pitch, like this:

"Hi, I'm Jane Smith. I'm a first-semester junior in electrical

engineering interested in drone applications. I understand your company develops XYZ...I'd like to know more about that!"

This last example is a good one in that it shows you've done your homework, yet it doesn't potentially limit the exchange if your interests, experience, or senior project topic are outside the scope of what they do. That is, while you might be very interested in drones or aerospace, you might have other interests and be open to internships in others areas. Developing an elevator pitch is a bit of a craft.

Whatever the details you identify, *practice saying your elevator pitch aloud*. Many job seekers make the mistake of just "practicing in their heads," which often isn't enough when nerves strike and all the details swimming around in your head suddenly disappear. Practicing aloud cements your words and helps ensure you don't get tongue-tied when you're on the spot:

- Practice with your spouse, significant other, or roommate...and ask for feedback. Did you make eye contact? Did you speak loudly and clearly enough to be heard? (It's not uncommon that people's voices become softer when talking about themselves or when in uncomfortable situations.) Did what you say trigger a question for the other person to ask about?
- Practice in front of a mirror, even if you have someone to practice with. Did you maintain eye contact? Did you maintain

good posture? Did you control obvious signs of nervousness? If all else fails, practice in front of your cat. Or in the closet. Or in the car. Or wherever you feel comfortable. But do practice aloud. You'll be glad you did and regret if you didn't.

Prepare to Talk About at Least One Project or Course You've Completed

Participating companies work hard at making the career fair a friendly, positive experience. As such, it's unlikely that you'd be asked "hardball" questions; in fact, they're probably pretty skilled at eliciting details to help conversations flow. Even so, you should still come prepared to talk about one (maybe two) projects or courses you've completed, even if the experience or course is recent.

Practice talking about those details aloud, just as you should your elevator pitch. The goal isn't to memorize, but to ensure the details are fresh in your mind for the career fair. It's amazing how details escape us when nerves strike, even simple ones like the type of project, software used, hardware used, techniques, components, protocols, resources, libraries, reference designs, and so on. Some things to have fresh in your mind:

- What was the purpose of the project?
- What problems did it solve?
- Why were you interested in it?
- When did you complete it?
- What factors influenced decisions in choosing [tools, technologies, components, protocols, resources,

libraries, reference designs, and so on]?

- What unexpected obstacles did you encounter along the way?
- How did you discover them?
- How did you solve them?
- What was the outcome?
- What would you do differently next time?

Again here, don't just think through these questions, but actually talk through them with your spouse, significant other, roommate, or professor. As with your elevator pitch, talking through these things will help solidify details and help you speak fluently at the job fair.

Other details to freshen up include answers to questions about why you're interested in engineering and what you like about (or why you chose) the program you're in. Hobbies are good as well, as they tend to support your interest in engineering or can show well-roundedness.

Conclusion

Yes, you're going to have to talk about yourself at career fairs; there's no avoiding it. *Listening* to what potential employers seek will provide the best clues to help you know what to say. If you've researched the companies, practiced your elevator pitch, and have project/course details fresh in your mind, you might be surprised at how easily discussions flow.

Good luck! And let us know how it goes! ●

Enterprise Drives Augmented Reality Demand

Consumer products garner the headlines, but industry is likely to drive AR commercialization.

By Steven Keeping for Mouser Electronics

While many things that Google comes up with seemingly turn to gold, Google Glass wasn't one of them. According to *Forbes* magazine, the company's augmented reality (AR) headset will go down in the annals of bad product launches because it was poorly designed, confusingly marketed, and badly timed.

The voice-controlled, head-mounted display was meant to introduce the benefits of AR—a technology that enhances human perception of the physical environment with computer-generated graphics—to the masses but failed. The product's appeal turned out to be limited to a few New York and Silicon Valley early adopters. And even they soon ditched the glasses and returned to smartphones when buggy software and distrust of filming in public places became apparent. Faced with a damp squib, the glasses were quietly withdrawn.

However, the company shed few tears over its aborted foray into AR-for-the-masses because it gained valuable experience. Armed with that knowledge, Alphabet,

Inc. (Google's parent company) has brought Google Glass back, only this time geared toward factory workers, not the average consumer.

Some would argue the first-generation device never really went away. Pioneering enterprises—initially overlooked by Google Glass marketers—used the consumer product to project in new ways. For example, AR was used to animate instructions, which was found to be an effective way to deskill complex manual tasks and to improve quality. Further, head-mounted AR raised productivity, reduced errors, and improved safety. A report from *Bloomberg* even noted some firms went to the extent of hiring third-party software developers to customize the product for specific tasks.

Enter “Glass Enterprise Edition”

Such encouragement resulted in Alphabet's launch of “Glass Enterprise Edition” targeted for the workplace and boasting several upgrades over the consumer product, including a better camera, faster microprocessor, improved



Figure 1: Microsoft's HoloLens is finding favor with automotive makers such as Volvo to help engineers visualize new concepts in three dimensions. (Source: Microsoft)

Wi-Fi, and longer battery life...plus a red light LED that illuminates to let others know they're being recorded. But perhaps the key improvement is the packaging of the electronics into a small module that can be attached to safety glasses or prescription spectacles, making it easier for workers to use. While employees are much less concerned about the aesthetics of wearables than consumers, streamlining previously chunky AR devices improves comfort and hence usability.

According to a report in *Wired*, sales of Glass Enterprise Edition are still only modest, and many large companies are taking the

product on a trial basis only. But that's not stopped Alphabet's product managers sounding bullish about the product's workplace prospects. "This isn't an experiment. Now we are in full-on production with our customers and with our partners," project lead Jay Kothari told *Wired*.

Alphabet is not alone in realizing AR is a little underdeveloped for the consumer, but practical for the worker. Seattle-based computer-software, -hardware, and -services giant Microsoft has also entered the fray with HoloLens, a "mixed reality" holographic computer and head-mounted display (**Figure 1**). And Japan's Sony is tapping

into rising industrial interest with SmartEyeGlass.

Focus on Specifics

With its first-generation Google Glass, Alphabet repeated a mistake all too common with tech companies: Aiming for volume sales by targeting the consumer market. While that was a strategy that worked well for smartphones, it hasn't proven quite so successful for **wearables**.

The consumer was quick to realize the smartphone had many specific uses—like communication, connectivity, photography—while the smartwatch, for example, seemed to just duplicate many

of those uses while bringing few useful features of its own. For instance, a smartwatch's fitness tracking functionality has little long-term use; most people can tell if they are fit or not by taking the stairs instead of the elevator and seeing if they're out of breath as a result.

But where smartwatches will really take off is when they offer specialized functionality such as **constant glucose monitoring**, fall alerts for seniors, or in occupations like driving public service vehicles where operators benefit from observing notifications without removing their hands from the wheel.

Similarly, early AR did little more for consumers than shift information presentation from the handset to a heads-up display—useful, but not earthshattering enough to justify shelling out thousands of dollars. In contrast, freeing up the workers' hands by presenting instructions directly in their line of sight is a big deal for industries where efficiency gains equal greater profits.

Impacting the Bottom Line

Enterprise is excellent at spotting where a new technology like AR can address specific challenge, especially if the result impacts the bottom line. Robots were added to car assembly lines because they automated tasks where human error led to safety issues; machine-to-machine wireless communications was embraced because it predicted the need for maintenance in advance of machines grinding to a halt. In both, AR reduced costs by eliminating the need for skilled workers.

And so it appears to be with AR. German carmakers Volkswagen and BMW have experimented with the technology for communication between assembly-line teams. Similarly, aircraft manufacturer Boeing has equipped its technicians with AR headsets to speed navigation of planes' wiring harnesses. And AccuVein, a portable AR device that projects an accurate image of the location of peripheral veins onto a patient's skin, is in use in hospitals across the U.S., assisting healthcare professionals to improve venipuncture.

Elevator manufacturer ThyssenKrupp has taken things even further by equipping all its field engineers with Microsoft's HoloLens so they can look at a piece of broken elevator equipment to see what repairs are needed. Better yet, IoT-connected elevators tell technicians in advance what tools to are needed to make repairs, eliminating time-consuming and costly back and forth.

Too Soon to Call

It is too early in AR's development to tell if this generation of the technology will be a runaway success. In the consumer sector, the signs aren't great. Virtual Reality (VR), AR's much-hyped bigger brother, is not exactly flying off the shelves; a recent report in *The Economist* noted, for example, that the 2016 U.S. sales forecast for Sony's PlayStation VR headset was cut from 2.6 million to just 750,000 shipments.

And although VR's immersive experience might have some applications in training and

education, enterprise applications will do little to boost its chances of mainstream acceptance. In contrast, AR's long-term prospects are dramatically boosted by industry's embrace. And, in the same way that PCs, Wi-Fi, and smartphones built on clunky, expensive, and power-sapping first-generation technology to become the sophisticated products we use today, industry's investment in the technology will ensure AR headsets will become more streamlined, powerful, and efficient—and ultimately much more appealing to the consumer.

AR's interleaving of the virtual and real worlds to improve human performance will become a compelling draw for profit-making concerns and the public alike. It's reality, only better.

For more on the future of AR see Mouser Electronics' ebook **Augmented Reality**. ●



mouser.com

The Newest Products for Your Newest Designs®

Honeywell
EMERSON
Network Power

TDK
EPCOS
VISHAY
STE
connectivity
AUTHORIZED DISTRIBUTOR

Infineon
nichicon

HRS
HIROSE ELECTRIC CO., LTD.
AVX
A KYOCERA GROUP COMPANY

TOSHIBA
intel
TEXAS INSTRUMENTS
BROADCOM
connecting everything.
SILICON LABS

Panasonic
ANALOG DEVICES
AHEAD OF WHAT'S POSSIBLE™
molex

BOURNS
DIGI
maxim integrated
muRata
INNOVATOR IN ELECTRONICS

OMRON
ELECTRONIC COMPONENTS
ST
life.augmented
NXP
Amphenol

Littelfuse
Expertise Applied | Answers Delivered
RENESAS
Electronic Components
KEMET
CHARGED.

CREE
AUTHORIZED DISTRIBUTOR
Microsemi
OSRAM
Opto Semiconductors
PHENIX CONTACT

CYPRESS
EMBEDDED IN TOMORROW
Coilcraft
ON Semiconductor
ON

MICROCHIP
LUMILEDS

mouser.com

The widest selection of the newest products.

Over 4 million products from over 600 manufacturers.



Authorized distributor of semiconductors and electronic components for design engineers.



MOUSER
ELECTRONICS