

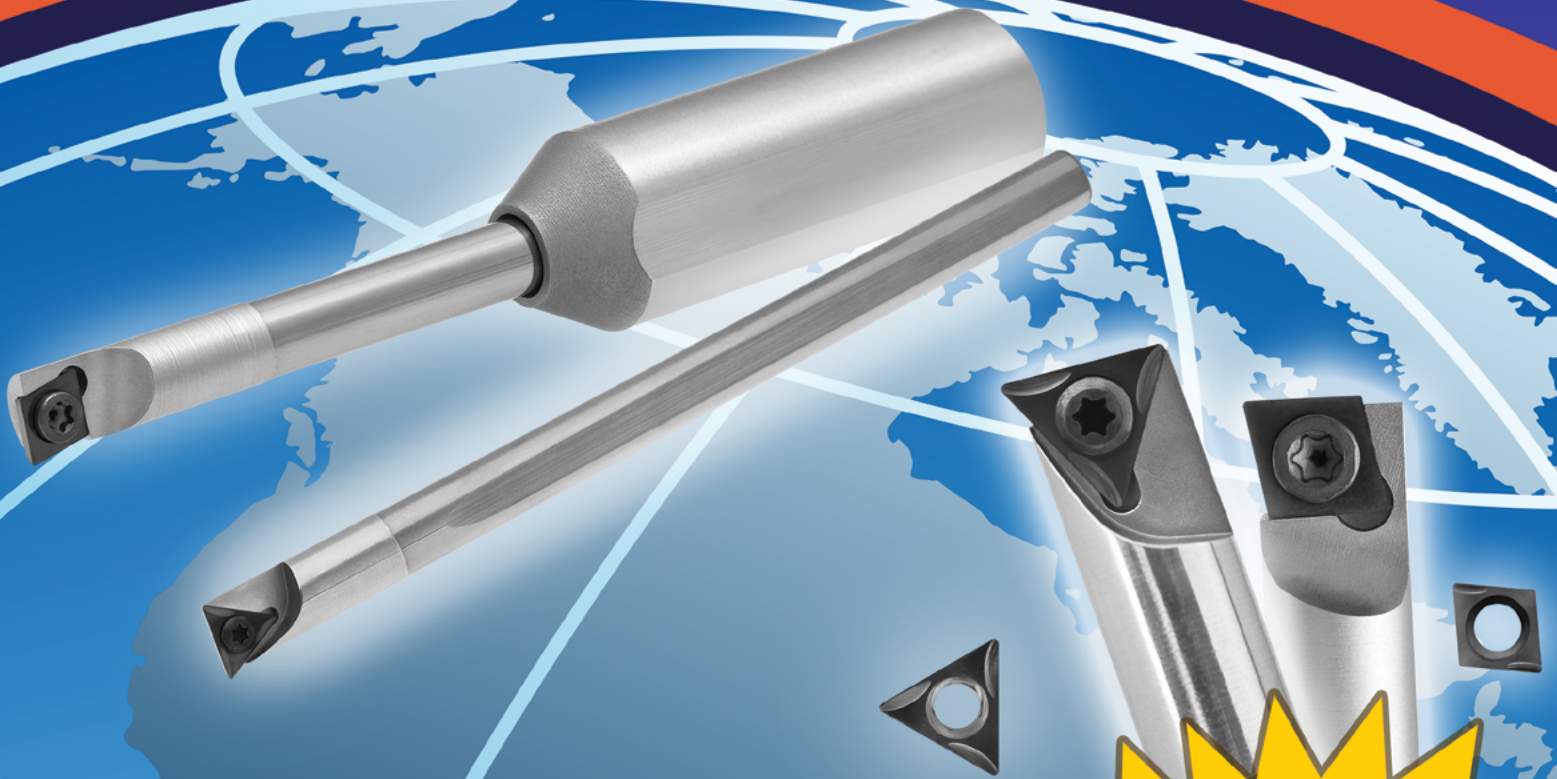

Scientific Cutting Tools Advantage

INDEXABLE TOOLING



FEATURING
NEW ITEMS &
ADVANTAGE TOOLS

Selecting an Advantage Boring Bar

1	From the part or print, obtain the diameter of hole to be machined. From the SCT Advantage Catalog select the boring bar that has a minimum bore diameter smaller than the diameter to be machined.
2	Check machine for shank size needed. If the shank needs to be larger than bar go to page 16 of the SCT Advantage Catalog.
3	Match the operation needed on the part with the necessary lead angle. Select 0° lead to bore through a part or to a shoulder. Select 5° lead to bore and face a shoulder.
4	Choose from flat top or chip control insert based on application and material being machined.
5	Choose from .003", .007", or .015" radius based on finish required and part specifications for corner radius.

LEARN MORE ABOUT THE SCT ADVANTAGE...

- Micro-grain carbide shanks provide maximum rigidity.
- Unique top cut strengthens pocket by 40% and directs chips away from cut zone.
- Inserts can be ordered separately/additionally in packs of five.
- Low profile screw allows more space for chips.
- Head is heat treated to reduce pocket damage.
- All inserts are precision ground and top polished.
- Sets provide optimal storage and ease of access to components.
- A complete set includes one bar, one key, and five inserts with matching screws.



Selecting an Advantage Insert Grade

UNCOATED	Uncoated is a sub-micron sinter hipped carbide grade for machining steel from 75 to 350 SFM and non ferrous materials from 75 to 600 SFM.
ALTiN+	ALTiN+ is a premium coated grade for steel, cast irons and high temperature alloys from 150 to 500 SFM.
ZrCN	ZrCN is a superior coated grade for machining non-ferrous materials from 200 to 2000 SFM.

Table of Contents

DIAMOND SHAPED CARBIDE INSERT SETS Page

3/16" SHANK RIGHT-HAND SETS.....	4
3/16" SHANK LEFT-HAND SETS	5
1/4" SHANK RIGHT-HAND SETS.....	6
1/4" SHANK LEFT-HAND SETS.....	7
5/16" SHANK RIGHT-HAND SETS	8
5/16" SHANK LEFT-HAND SETS	9
1/2" RIGHT-HAND STEP BAR SETS	16

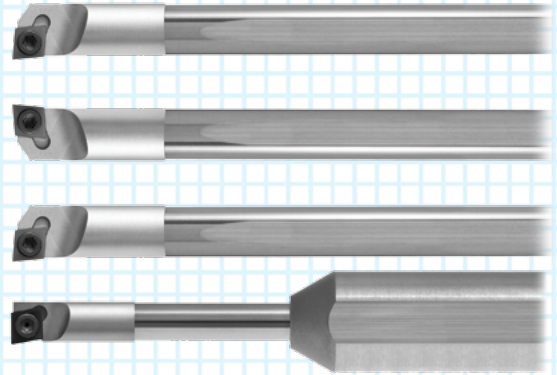

TRIANGLE SHAPED CARBIDE INSERT SETS

1/4" SHANK RIGHT-HAND SETS	10
1/4" SHANK LEFT-HAND SETS.....	11
5/16" SHANK RIGHT-HAND SETS	12
5/16" SHANK LEFT-HAND SETS.....	13
3/8" SHANK RIGHT-HAND SETS	14
3/8" SHANK LEFT-HAND SETS.....	15
1/2" RIGHT-HAND STEP BAR SETS.....	16

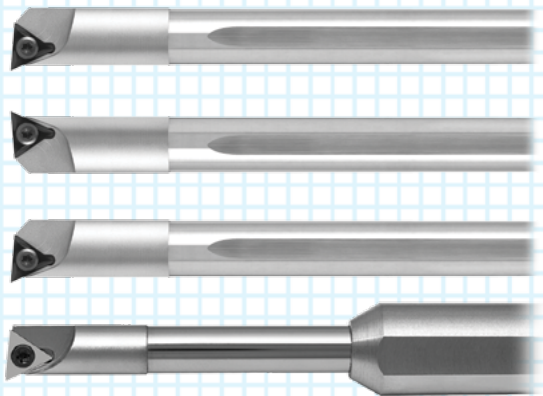

1/2" BORING BAR

1/2" SHANK RIGHT-HAND.....	16
1/2" SHANK LEFT-HAND	16



CARBIDE INSERT PACKS

80° DIAMOND FLAT TOP .156 IC.....	17
80° DIAMOND CHIP CONTROL .156 IC.....	17
60° TRIANGLE FLAT TOP .160 IC.....	17
60° TRIANGLE CHIP CONTROL .160 IC.....	17
60° TRIANGLE FLAT TOP .250 IC.....	17
60° TRIANGLE CHIP CONTROL .250 IC.....	17

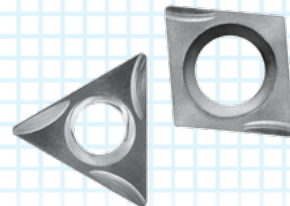

REFERENCE INDEX

BAR TO INSERT COMPATABILITY CHART

INDEXABLE BORING BAR 3/16" SHANK

RIGHT-HAND BORING BAR SETS WITH DIAMOND SHAPED CARBIDE INSERTS

- Set includes one bar, five inserts with screws, and key.
- Set comes in a customized reusable box for easy storage.
- Inserts can be ordered separately in packs of five.



Shown Above: Example of Set

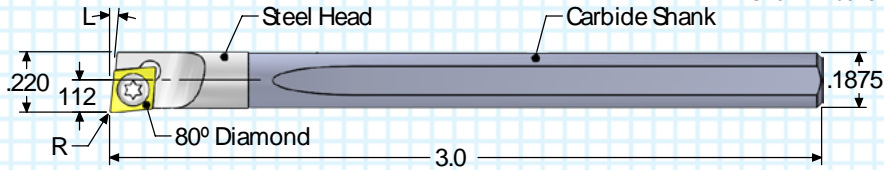

RIGHT HAND SETS					
ONE BAR		FIVE INSERTS		ORDER NUMBER	
"L" ANGLE	BAR FLAT	INSERT PACK	"R" RADIUS	COMPLETE SET	
				UNCOATED	ALTiN+
5°	NONE	ACD5071(E)	0.007	ACBC187R5R07	ACBC187R5R07E
		ACD5151(E)	0.015	ACBC187R5R15	ACBC187R5R15E
	FLAT	ACD5071(E)	0.007	ACBC187F5R07	ACBC187F5R07E
		ACD5151(E)	0.015	ACBC187F5R15	ACBC187F5R15E
0°	NONE	ACD5071(E)	0.007	ACBC187R0R07	ACBC187R0R07E
		ACD5151(E)	0.015	ACBC187R0R15	ACBC187R0R15E
	FLAT	ACD5071(E)	0.007	ACBC187F0R07	ACBC187F0R07E
		ACD5151(E)	0.015	ACBC187F0R15	ACBC187F0R15E

ADDITIONAL INSERT OPTIONS AVAILABLE EXCLUSIVELY AS INSERT PACKS (SEE BELOW)

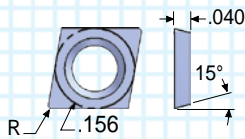

80° DIAMOND FLAT TOP

5 PC INSERT PACK W/ SCREWS - .156 IC

FIVE SCREWS	"R" CORNER RADIUS	ORDER NUMBER		
		FIVE UNCOATED	FIVE ALTiN+	FIVE ZrCN
AT6+	0.003	ACD5031	ACD5031E	ACD5031Z
	0.007	ACD5071	ACD5071E	ACD5071Z
	0.015	ACD5151	ACD5151E	ACD5151Z

REPLACEMENT FLAG KEY (2 PACK)	ORDER NUMBER
AT6+	A6KEY

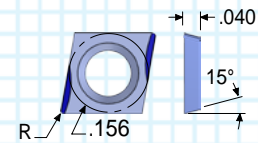

80° DIAMOND CHIP CONTROL

5 PC INSERT PACK W/ SCREWS - .156 IC

FIVE SCREWS	"R" CORNER RADIUS	ORDER NUMBER	
		FIVE UNCOATED	FIVE ALTiN+
AT6+	0.007	ACD507L2	ACD507L2E
	0.015	ACD515L2	ACD515L2E

REPLACEMENT SCREWS (5 PACK)	ORDER NUMBER
AT6+ SCREWS	A6SCREWS

INDEXABLE BORING BAR 3/16" SHANK

LEFT-HAND BORING BAR SETS WITH DIAMOND SHAPED CARBIDE INSERTS

- Set includes one bar, five inserts with screws, and key.
- Set comes in a customized reusable box for easy storage.
- Inserts can be ordered separately in packs of five.



Shown Above: Example of Set

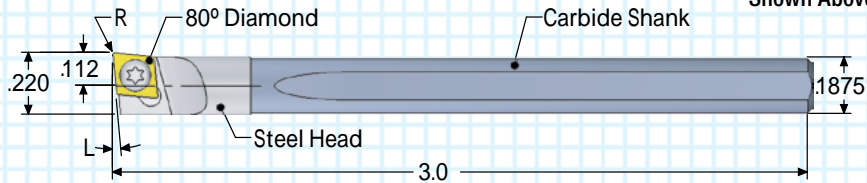

LEFT HAND SETS					
ONE BAR		FIVE INSERTS		ORDER NUMBER	
"L" ANGLE	BAR FLAT	INSERT PACK	"R" RADIUS	COMPLETE SET	
				UNCOATED	ALTiN+
5°	NONE	ACD5071(E)	0.007	ACBC187R5L07	ACBC187R5L07E
		ACD5151(E)	0.015	ACBC187R5L15	ACBC187R5L15E
	FLAT	ACD5071(E)	0.007	ACBC187F5L07	ACBC187F5L07E
		ACD5151(E)	0.015	ACBC187F5L15	ACBC187F5L15E
0°	NONE	ACD5071(E)	0.007	ACBC187R0L07	ACBC187R0L07E
		ACD5151(E)	0.015	ACBC187R0L15	ACBC187R0L15E
	FLAT	ACD5071(E)	0.007	ACBC187F0L07	ACBC187F0L07E
		ACD5151(E)	0.015	ACBC187F0L15	ACBC187F0L15E

ADDITIONAL INSERT OPTIONS AVAILABLE EXCLUSIVELY AS INSERT PACKS (SEE BELOW)

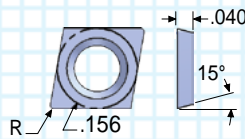

80° DIAMOND FLAT TOP 5 PC INSERT PACK W/ SCREWS - .156 IC

FIVE SCREWS	"R" CORNER RADIUS	ORDER NUMBER		
		FIVE UNCOATED	FIVE ALTiN+	FIVE ZrCN
AT6+	0.003	ACD5031	ACD5031E	ACD5031Z
	0.007	ACD5071	ACD5071E	ACD5071Z
	0.015	ACD5151	ACD5151E	ACD5151Z

REPLACEMENT FLAG KEY (2 PACK)	ORDER NUMBER
AT6+	A6KEY

REPLACEMENT SCREWS (5 PACK)	ORDER NUMBER
AT6+ SCREWS	A6SCREWS

INDEXABLE BORING BAR 1/4" SHANK

RIGHT-HAND BORING BAR SETS WITH DIAMOND SHAPED CARBIDE INSERTS

- Set includes one bar, five inserts with screws, and key.
- Set comes in a customized reusable box for easy storage.
- Inserts can be ordered separately in packs of five.



Shown Above: Example of Set

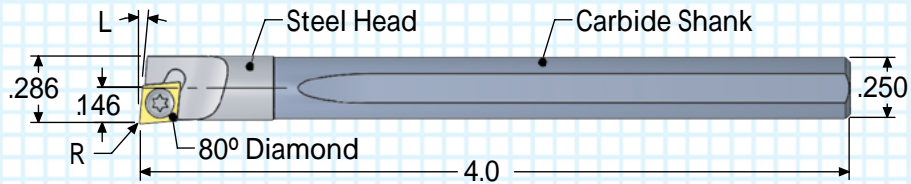

RIGHT HAND SETS					
ONE BAR		FIVE INSERTS		ORDER NUMBER	
"L" ANGLE	BAR FLAT	INSERT PACK	"R" RADIUS	COMPLETE SET	
				UNCOATED	ALTiN+
5°	FLAT	ACD5071(E)	0.007	ACBC250F5R07	ACBC250F5R07E
		ACD5151(E)	0.015	ACBC250F5R15	ACBC250F5R15E
0°	FLAT	ACD5071(E)	0.007	ACBC250F0R07	ACBC250F0R07E
		ACD5151(E)	0.015	ACBC250F0R15	ACBC250F0R15E
ADDITIONAL INSERT OPTIONS AVAILABLE EXCLUSIVELY AS INSERT PACKS (SEE BELOW)					

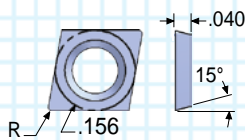

80° DIAMOND FLAT TOP

5 PC INSERT PACK W/ SCREWS - .156 IC

FIVE SCREWS	"R" CORNER RADIUS	ORDER NUMBER		
		FIVE UNCOATED	FIVE ALTiN+	FIVE ZrCN
AT6+	0.003	ACD5031	ACD5031E	ACD5031Z
	0.007	ACD5071	ACD5071E	ACD5071Z
	0.015	ACD5151	ACD5151E	ACD5151Z

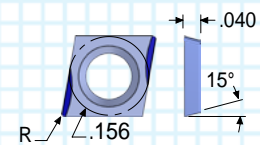

80° DIAMOND CHIP CONTROL

5 PC INSERT PACK W/ SCREWS - .156 IC

FIVE SCREWS	"R" CORNER RADIUS	ORDER NUMBER	
		FIVE UNCOATED	FIVE ALTiN+
AT6+	0.007	ACD507L2	ACD507L2E
	0.015	ACD515L2	ACD515L2E

REPLACEMENT FLAG KEY (2 PACK)	ORDER NUMBER
AT6+	AGKEY

REPLACEMENT SCREWS (5 PACK)	ORDER NUMBER
AT6+ SCREWS	A6SCREWS

INDEXABLE BORING BAR 1/4" SHANK

LEFT-HAND BORING BAR SETS WITH DIAMOND SHAPED CARBIDE INSERTS

- Set includes one bar, five inserts with screws, and key.
- Set comes in a customized reusable box for easy storage.
- Inserts can be ordered separately in packs of five.



Shown Above: Example of Set

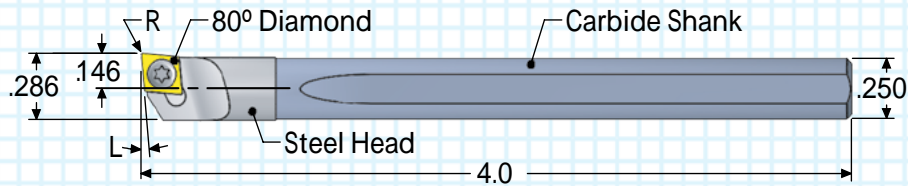

LEFT HAND SETS					
ONE BAR		FIVE INSERTS		ORDER NUMBER	
"L" ANGLE	BAR FLAT	INSERT PACK	"R" RADIUS	COMPLETE SET	
				UNCOATED	ALTiN+
5°	FLAT	ACD5071(E)	0.007	ACBC250F5L07	ACBC250F5L07E
		ACD5151(E)	0.015	ACBC250F5L15	ACBC250F5L15E
0°	FLAT	ACD5071(E)	0.007	ACBC250F0L07	ACBC250F0L07E
		ACD5151(E)	0.015	ACBC250F0L15	ACBC250F0L15E

ADDITIONAL INSERT OPTIONS AVAILABLE EXCLUSIVELY AS INSERT PACKS (SEE BELOW)

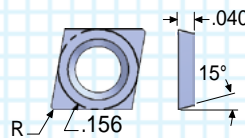

80° DIAMOND FLAT TOP 5 PC INSERT PACK W/ SCREWS - .156 IC

FIVE SCREWS	"R" CORNER RADIUS	ORDER NUMBER		
		FIVE UNCOATED	FIVE ALTiN+	FIVE ZrCN
AT6+	0.003	ACD5031	ACD5031E	ACD5031Z
	0.007	ACD5071	ACD5071E	ACD5071Z
	0.015	ACD5151	ACD5151E	ACD5151Z

REPLACEMENT FLAG KEY (2 PACK)	ORDER NUMBER
AT6+	A6KEY

REPLACEMENT SCREWS (5 PACK)	ORDER NUMBER
AT6+ SCREWS	A6SCREWS

INDEXABLE BORING BAR 5/16" SHANK

RIGHT-HAND BORING BAR SETS WITH DIAMOND SHAPED CARBIDE INSERTS

- Set includes one bar, five inserts with screws, and key.
- Set comes in a customized reusable box for easy storage.
- Inserts can be ordered separately in packs of five.



Shown Above: Example of Set

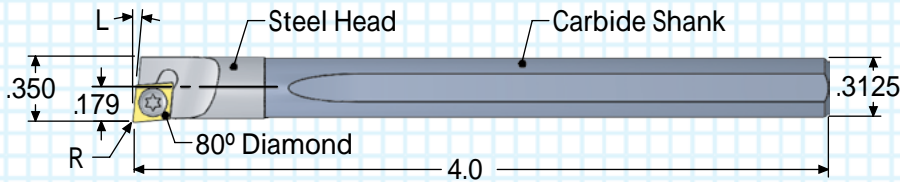

RIGHT HAND SETS					
ONE BAR		FIVE INSERTS		ORDER NUMBER	
"L" ANGLE	BAR FLAT	INSERT PACK	"R" RADIUS	COMPLETE SET	
				UNCOATED	ALTiN+
5°	FLAT	ACD5071(E)	0.007	ACBC312F5R07	ACBC312F5R07E
		ACD5151(E)	0.015	ACBC312F5R15	ACBC312F5R15E
0°	FLAT	ACD5071(E)	0.007	ACBC312F0R07	ACBC312F0R07E
		ACD5151(E)	0.015	ACBC312F0R15	ACBC312F0R15E

ADDITIONAL INSERT OPTIONS AVAILABLE EXCLUSIVELY AS INSERT PACKS (SEE BELOW)

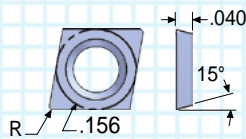

80° DIAMOND FLAT TOP

5 PC INSERT PACK W/ SCREWS - .156 IC

FIVE SCREWS	"R" CORNER RADIUS	ORDER NUMBER		
		FIVE UNCOATED	FIVE ALTiN+	FIVE ZrCN
AT6+	0.003	ACD5031	ACD5031E	ACD5031Z
	0.007	ACD5071	ACD5071E	ACD5071Z
	0.015	ACD5151	ACD5151E	ACD5151Z

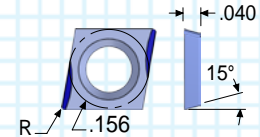

80° DIAMOND CHIP CONTROL

5 PC INSERT PACK W/ SCREWS - .156 IC

FIVE SCREWS	"R" CORNER RADIUS	ORDER NUMBER	
		FIVE UNCOATED	FIVE ALTiN+
AT6+	0.007	ACD507L2	ACD507L2E
	0.015	ACD515L2	ACD515L2E

REPLACEMENT FLAG KEY (2 PACK)	ORDER NUMBER
AT6+	A6KEY

REPLACEMENT SCREWS (5 PACK)	ORDER NUMBER
AT6+ SCREWS	A6SCREWS

INDEXABLE BORING BAR 5/16" SHANK

LEFT-HAND BORING BAR SETS WITH DIAMOND SHAPED CARBIDE INSERTS

- Set includes one bar, five inserts with screws, and key.
- Set comes in a customized reusable box for easy storage.
- Inserts can be ordered separately in packs of five.



Shown Above: Example of Set

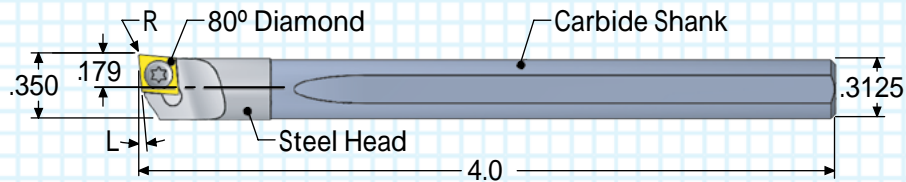

LEFT HAND SETS					
ONE BAR		FIVE INSERTS		ORDER NUMBER	
"L" ANGLE	BAR FLAT	INSERT PACK	"R" RADIUS	COMPLETE SET	
				UNCOATED	ALTiN+
5°	FLAT	ACD5071(E)	0.007	ACBC312F5L07	ACBC312F5L07E
		ACD5151(E)	0.015	ACBC312F5L15	ACBC312F5L15E
0°	FLAT	ACD5071(E)	0.007	ACBC312F0L07	ACBC312F0L07E
		ACD5151(E)	0.015	ACBC312F0L15	ACBC312F0L15E

ADDITIONAL INSERT OPTIONS AVAILABLE EXCLUSIVELY AS INSERT PACKS (SEE BELOW)

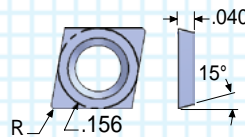

80° DIAMOND FLAT TOP 5 PC INSERT PACK W/ SCREWS - .156 IC

FIVE SCREWS	"R" CORNER RADIUS	ORDER NUMBER		
		FIVE UNCOATED	FIVE ALTiN+	FIVE ZrCN
AT6+	0.003	ACD5031	ACD5031E	ACD5031Z
	0.007	ACD5071	ACD5071E	ACD5071Z
	0.015	ACD5151	ACD5151E	ACD5151Z

REPLACEMENT FLAG KEY (2 PACK)	ORDER NUMBER
AT6+	A6KEY

REPLACEMENT SCREWS (5 PACK)	ORDER NUMBER
AT6+ SCREWS	A6SCREWS

INDEXABLE BORING BAR 1/4" SHANK

RIGHT-HAND BORING BAR SETS WITH TRIANGLE SHAPED CARBIDE INSERTS

- Set includes one bar, five inserts with screws, and key.
- Set comes in a customized reusable box for easy storage.
- Inserts can be ordered seperately in packs of five.
- Unique top cut strengthens pocket by 40%.



Shown Above: Example of Set

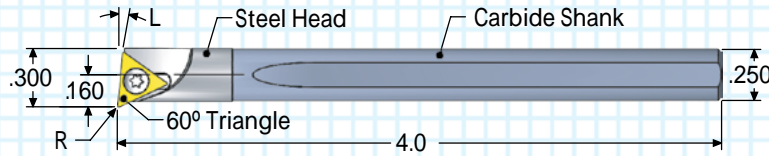

RIGHT HAND SETS					
ONE BAR		FIVE INSERTS		ORDER NUMBER	
"L" ANGLE	BAR FLAT	INSERT PACK	"R" RADIUS	COMPLETE SET	
				UNCOATED	ALTiN+
5°	NONE	ATD5071(E)	0.007	ACBT250R5R07	ACBT250R5R07E
		ATD5151(E)	0.015	ACBT250R5R15	ACBT250R5R15E
	FLAT	ATD5071(E)	0.007	ACBT250F5R07	ACBT250F5R07E
		ATD5151(E)	0.015	ACBT250F5R15	ACBT250F5R15E
0°	NONE	ATD5071(E)	0.007	ACBT250R0R07	ACBT250R0R07E
		ATD5151(E)	0.015	ACBT250R0R15	ACBT250R0R15E
	FLAT	ATD5071(E)	0.007	ACBT250F0R07	ACBT250F0R07E
		ATD5151(E)	0.015	ACBT250F0R15	ACBT250F0R15E

ADDITIONAL INSERT OPTIONS AVAILABLE EXCLUSIVELY AS INSERT PACKS (SEE BELOW)

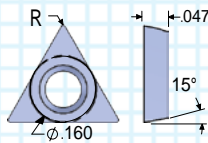

60° TRIANGLE FLAT TOP FIVE PIECE INSERT KIT - .160 IC

FIVE SCREWS	"R" CORNER RADIUS	ORDER NUMBER		
		FIVE UNCOATED	FIVE ALTiN+	FIVE ZrCN
AT6+	0.003	ATD5031	ATD5031E	ATD5031Z
	0.007	ATD5071	ATD5071E	ATD5071Z
	0.015	ATD5151	ATD5151E	ATD5151Z

REPLACEMENT FLAG KEY (2 PACK)	ORDER NUMBER
AT6+	A6KEY

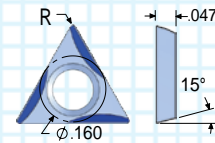

60° TRIANGLE CHIP CONTROL FIVE PIECE INSERT KIT - .160 IC

FIVE SCREWS	"R" CORNER RADIUS	ORDER NUMBER	
		FIVE UNCOATED	FIVE ALTiN+
AT6+	0.007	ATD507L2	ATD507L2E
	0.015	ATD515L2	ATD515L2E

REPLACEMENT SCREWS (5 PACK)	ORDER NUMBER
AT6+ SCREWS	A6SCREWS

INDEXABLE BORING BAR 1/4" SHANK

LEFT-HAND BORING BAR SETS WITH TRIANGLE SHAPED CARBIDE INSERTS

- Set includes one bar, five inserts with screws, and key.
- Set comes in a customized reusable box for easy storage.
- Inserts can be ordered separately in packs of five.
- Unique top cut strengthens pocket by 40%.



Shown Above: Example of Set

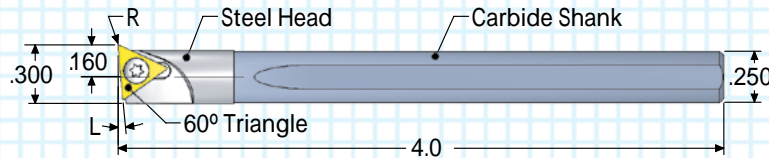

LEFT HAND SETS					
ONE BAR		FIVE INSERTS		ORDER NUMBER	
"L" ANGLE	BAR FLAT	INSERT PACK	"R" RADIUS	COMPLETE SET	
				UNCOATED	ALTiN+
5°	NONE	ATD5071(E)	0.007	ACBT250R5L07	ACBT250R5L07E
		ATD5151(E)	0.015	ACBT250R5L15	ACBT250R5L15E
	FLAT	ATD5071(E)	0.007	ACBT250F5L07	ACBT250F5L07E
		ATD5151(E)	0.015	ACBT250F5L15	ACBT250F5L15E
0°	NONE	ATD5071(E)	0.007	ACBT250R0L07	ACBT250R0L07E
		ATD5151(E)	0.015	ACBT250R0L15	ACBT250R0L15E
	FLAT	ATD5071(E)	0.007	ACBT250F0L07	ACBT250F0L07E
		ATD5151(E)	0.015	ACBT250F0L15	ACBT250F0L15E

ADDITIONAL INSERT OPTIONS AVAILABLE EXCLUSIVELY AS INSERT PACKS (SEE BELOW)

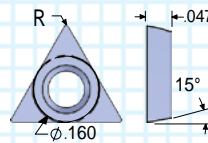

60° TRIANGLE FLAT TOP FIVE PIECE INSERT KIT - .160 IC

FIVE SCREWS	"R" CORNER RADIUS	ORDER NUMBER		
		FIVE UNCOATED	FIVE ALTiN+	FIVE ZrCN
AT6+	0.003	ATD5031	ATD5031E	ATD5031Z
	0.007	ATD5071	ATD5071E	ATD5071Z
	0.015	ATD5151	ATD5151E	ATD5151Z

REPLACEMENT FLAG KEY (2 PACK)	ORDER NUMBER
AT6+	A6KEY

REPLACEMENT SCREWS (5 PACK)	ORDER NUMBER
AT6+ SCREWS	A6SCREWS

INDEXABLE BORING BAR 5/16" SHANK

RIGHT-HAND BORING BAR SETS WITH TRIANGLE SHAPED CARBIDE INSERTS

- Set includes one bar, five inserts with screws, and key.
- Set comes in a customized reusable box for easy storage.
- Inserts can be ordered seperately in packs of five.
- Unique top cut strengthens pocket by 40%.



Shown Above: Example of Set

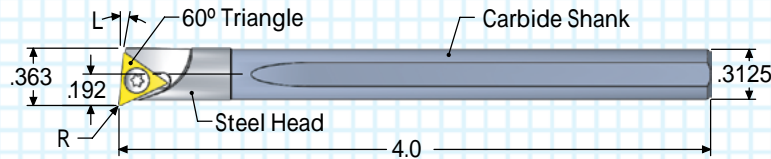

RIGHT HAND SETS					
ONE BAR		FIVE INSERTS		ORDER NUMBER	
"L" ANGLE	BAR FLAT	INSERT PACK	"R" RADIUS	COMPLETE SET	
				UNCOATED	ALTiN+
5°	NONE	ATD5071(E)	0.007	ACBT312R5R07	ACBT312R5R07E
		ATD5151(E)	0.015	ACBT312R5R15	ACBT312R5R15E
	FLAT	ATD5071(E)	0.007	ACBT312F5R07	ACBT312F5R07E
		ATD5151(E)	0.015	ACBT312F5R15	ACBT312F5R15E
0°	NONE	ATD5071(E)	0.007	ACBT312R0R07	ACBT312R0R07E
		ATD5151(E)	0.015	ACBT312R0R15	ACBT312R0R15E
	FLAT	ATD5071(E)	0.007	ACBT312F0R07	ACBT312F0R07E
		ATD5151(E)	0.015	ACBT312F0R15	ACBT312F0R15E

ADDITIONAL INSERT OPTIONS AVAILABLE EXCLUSIVELY AS INSERT PACKS (SEE BELOW)

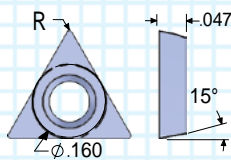

60° TRIANGLE FLAT TOP FIVE PIECE INSERT KIT - .160 IC

FIVE SCREWS	"R" CORNER RADIUS	ORDER NUMBER		
		FIVE UNCOATED	FIVE ALTiN+	FIVE ZrCN
AT6+	0.003	ATD5031	ATD5031E	ATD5031Z
	0.007	ATD5071	ATD5071E	ATD5071Z
	0.015	ATD5151	ATD5151E	ATD5151Z

REPLACEMENT FLAG KEY (2 PACK)	ORDER NUMBER
AT6+	A6KEY

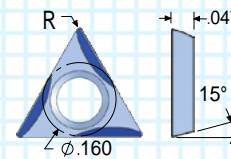

60° TRIANGLE CHIP CONTROL FIVE PIECE INSERT KIT - .160 IC

FIVE SCREWS	"R" CORNER RADIUS	ORDER NUMBER	
		FIVE UNCOATED	FIVE ALTiN+
AT6+	0.007	ATD507L2	ATD507L2E
	0.015	ATD515L2	ATD515L2E

REPLACEMENT SCREWS (5 PACK)	ORDER NUMBER
AT6+ SCREWS	A6SCREWS

INDEXABLE BORING BAR 5/16" SHANK

LEFT-HAND BORING BAR SETS WITH TRIANGLE SHAPED CARBIDE INSERTS

- Set includes one bar, five inserts with screws, and key.
- Set comes in a customized reusable box for easy storage.
- Inserts can be ordered separately in packs of five.
- Unique top cut strengthens pocket by 40%.



Shown Above: Example of Set

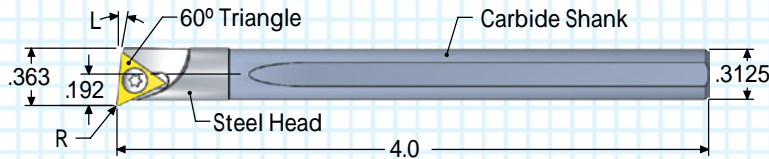

LEFT HAND SETS					
ONE BAR		FIVE INSERTS		ORDER NUMBER	
"L" ANGLE	BAR FLAT	INSERT PACK	"R" RADIUS	COMPLETE SET	
				UNCOATED	ALTIN+
5°	NONE	ATD5071(E)	0.007	ACBT312R5L07	ACBT312R5L07E
		ATD5151(E)	0.015	ACBT312R5L15	ACBT312R5L15E
	FLAT	ATD5071(E)	0.007	ACBT312F5L07	ACBT312F5L07E
		ATD5151(E)	0.015	ACBT312F5L15	ACBT312F5L15E
0°	NONE	ATD5071(E)	0.007	ACBT312R0L07	ACBT312R0L07E
		ATD5151(E)	0.015	ACBT312R0L15	ACBT312R0L15E
	FLAT	ATD5071(E)	0.007	ACBT312F0L07	ACBT312F0L07E
		ATD5151(E)	0.015	ACBT312F0L15	ACBT312F0L15E

ADDITIONAL INSERT OPTIONS AVAILABLE EXCLUSIVELY AS INSERT PACKS (SEE BELOW)

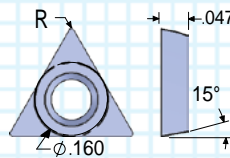

60° TRIANGLE FLAT TOP FIVE PIECE INSERT KIT - .160 IC

FIVE SCREWS	"R" CORNER RADIUS	ORDER NUMBER		
		FIVE UNCOATED	FIVE ALTiN+	FIVE ZrCN
AT6+	0.003	ATD5031	ATD5031E	ATD5031Z
	0.007	ATD5071	ATD5071E	ATD5071Z
	0.015	ATD5151	ATD5151E	ATD5151Z

REPLACEMENT FLAG KEY (2 PACK)	ORDER NUMBER
AT6+	A6KEY

REPLACEMENT SCREWS (5 PACK)	ORDER NUMBER
AT6+ SCREWS	A6SCREWS

INDEXABLE BORING BAR 3/8" SHANK

RIGHT-HAND BORING BAR SETS WITH TRIANGLE SHAPED CARBIDE INSERTS

- Set includes one bar, five inserts with screws, and key.
- Set comes in a customized reusable box for easy storage.
- Inserts can be ordered seperately in packs of five.
- Unique top cut strengthens pocket by 40%.



Shown Above: Example of Set

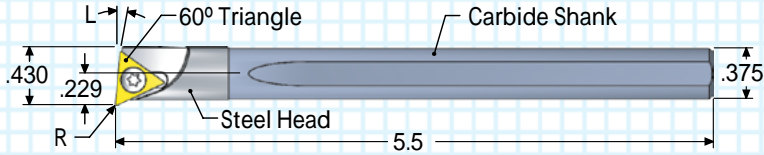

RIGHT HAND SETS					
ONE BAR		FIVE INSERTS		ORDER NUMBER	
"L" ANGLE	BAR FLAT	INSERT PACK	"R" RADIUS	COMPLETE SET	
				UNCOATED	ALTiN+
5°	NONE	ATP2071(E)	0.007	ACBT375R5R07	ACBT375R5R07E
		ATP2151(E)	0.015	ACBT375R5R15	ACBT375R5R15E
	FLAT	ATP2071(E)	0.007	ACBT375F5R07	ACBT375F5R07E
		ATP2151(E)	0.015	ACBT375F5R15	ACBT375F5R15E
0°	NONE	ATP2071(E)	0.007	ACBT375R0R07	ACBT375R0R07E
		ATP2151(E)	0.015	ACBT375R0R15	ACBT375R0R15E
	FLAT	ATP2071(E)	0.007	ACBT375F0R07	ACBT375F0R07E
		ATP2151(E)	0.015	ACBT375F0R15	ACBT375F0R15E

ADDITIONAL INSERT OPTIONS AVAILABLE EXCLUSIVELY AS INSERT PACKS (SEE BELOW)

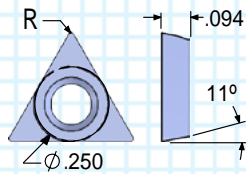

60° TRIANGLE FLAT TOP FIVE PIECE INSERT KIT - .250 IC

FIVE SCREWS	"R" CORNER RADIUS	ORDER NUMBER		
		FIVE UNCOATED	FIVE ALTiN+	FIVE ZrCN
AT8+	0.003	ATP2031	ATP2031E	ATP2031Z
	0.007	ATP2071	ATP2071E	ATP2071Z
	0.015	ATP2151	ATP2151E	ATP2151Z

REPLACEMENT FLAG KEY (2 PACK)	ORDER NUMBER
AT8+	A8KEY

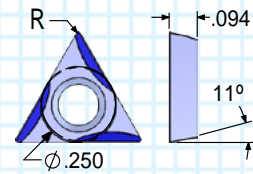

60° TRIANGLE CHIP CONTROL FIVE PIECE INSERT KIT - .250 IC

FIVE SCREWS	"R" CORNER RADIUS	ORDER NUMBER		
		FIVE UNCOATED	FIVE ALTiN+	FIVE ZrCN
AT8+	0.007	ATP207L2	ATP207L2E	ATP207L2Z
	0.015	ATP215L2	ATP215L2E	ATP215L2Z

REPLACEMENT SCREWS (5 PACK)	ORDER NUMBER
AT8+ SCREWS	A8SCREWS

INDEXABLE BORING BAR 3/8" SHANK

LEFT-HAND BORING BAR SETS WITH TRIANGLE SHAPED CARBIDE INSERTS

- Set includes one bar, five inserts with screws, and key.
- Set comes in a customized reusable box for easy storage.
- Inserts can be ordered separately in packs of five.
- Unique top cut strengthens pocket by 40%.



Shown Above: Example of Set

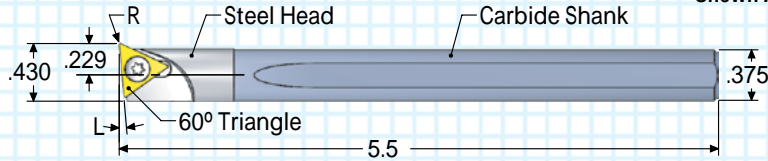

LEFT HAND SETS					
ONE BAR		FIVE INSERTS		ORDER NUMBER	
"L" ANGLE	BAR FLAT	INSERT PACK	"R" RADIUS	COMPLETE SET	
				UNCOATED	ALTiN+
5°	NONE	ATP2071(E)	0.007	ACBT375R5L07	ACBT375R5L07E
		ATP2151(E)	0.015	ACBT375R5L15	ACBT375R5L15E
	FLAT	ATP2071(E)	0.007	ACBT375F5L07	ACBT375F5L07E
		ATP2151(E)	0.015	ACBT375F5L15	ACBT375F5L15E
0°	NONE	ATP2071(E)	0.007	ACBT375R0L07	ACBT375R0L07E
		ATP2151(E)	0.015	ACBT375R0L15	ACBT375R0L15E
	FLAT	ATP2071(E)	0.007	ACBT375F0L07	ACBT375F0L07E
		ATP2151(E)	0.015	ACBT375F0L15	ACBT375F0L15E

ADDITIONAL INSERT OPTIONS AVAILABLE EXCLUSIVELY AS INSERT PACKS (SEE BELOW)

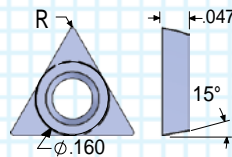

60° TRIANGLE FLAT TOP FIVE PIECE INSERT KIT - .250 IC

FIVE SCREWS	"R" CORNER RADIUS	ORDER NUMBER		
		FIVE UNCOATED	FIVE ALTiN+	FIVE ZrCN
AT8+	0.003	ATP2031	ATP2031E	ATP2031Z
	0.007	ATP2071	ATP2071E	ATP2071Z
	0.015	ATP2151	ATP2151E	ATP2151Z

REPLACEMENT FLAG KEY (2 PACK)	ORDER NUMBER
AT8+	A8KEY

REPLACEMENT SCREWS (5 PACK)	ORDER NUMBER
AT8+ SCREWS	A8SCREWS

INDEXABLE BORING BAR 1/2" SHANK

- Bar comes with key. Sets not available in this size.
- Insert packs are sold separately
- Unique top cut strengthens pocket by 40%

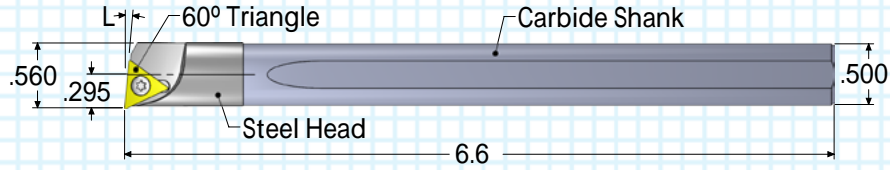

RIGHT HAND BAR				
"L" ANGLE	BAR FLAT	INSERT I.C.	INSERT SHAPE	ORDER #
				BAR ONLY
5°	NONE	0.250	TRIANGLE	ACBT500R5R
	FLAT	0.250	TRIANGLE	ACBT500F5R
0°	NONE	0.250	TRIANGLE	ACBT500R0R
	FLAT	0.250	TRIANGLE	ACBT500F0R
INSERTS SOLD SEPERATELY. SEE PAGE 17				

LEFT HAND BAR				
"L" ANGLE	BAR FLAT	INSERT I.C.	INSERT SHAPE	ORDER #
				BAR ONLY
5°	NONE	0.250	TRIANGLE	ACBT500R5L
	FLAT	0.250	TRIANGLE	ACBT500F5L
0°	NONE	0.250	TRIANGLE	ACBT500R0L
	FLAT	0.250	TRIANGLE	ACBT500F0L
INSERTS SOLD SEPERATELY. SEE PAGE 17				

INDEXABLE STEP BAR 1/2" SHANK

- Set includes one bar, five inserts with screws, and key.
- Set comes in a customized reusable box for easy storage and access.
- Inserts can be ordered separately in packs of five.

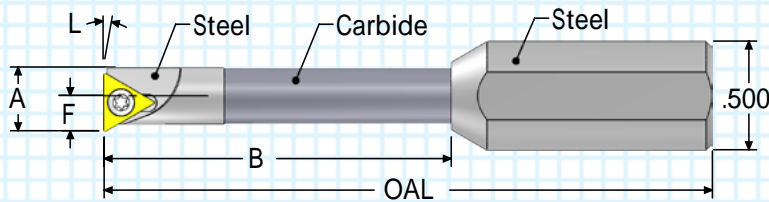

RIGHT HAND STEP BAR SETS										
ONE BAR							FIVE INSERTS		ORDER NUMBER COMPLETE SET	
"L" ANGLE	BAR FLAT	INSERT SHAPE	"A" MIN BORE	"B" MAX DEPTH	"F" DIM	OAL	INSERT PACK	"R" RADIUS	UNCOATED	ALTiN+
0°	FLAT	DIAMOND	0.220	1.31	0.112	2.800	ACD5071(E)	0.007	ACBC187S4F0R07	ACBC187S4F0R07E
	FLAT	TRIANGLE	0.300	1.75	0.160	3.200	ATD5071(E)	0.007	ACBT250S4F0R07	ACBT250S4F0R07E
	FLAT	TRIANGLE	0.363	2.19	0.192	3.600	ATD5071(E)	0.007	ACBT312S4F0R07	ACBT312S4F0R07E
INSERT PACKS ARE ALSO SOLD SEPERATELY. SEE PAGE 17										

INDEXABLE BORING BAR CARBIDE INSERTS

FLAT TOP AND CHIP CONTROL

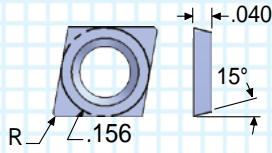

80° DIAMOND FLAT TOP
5 PC INSERT PACK W/ SCREWS - .156 IC
 FOR 3/16", 1/4" & 5/16" LEFT OR RIGHT HAND
 ACBC DIAMOND BORING BARS

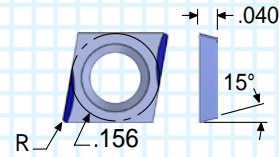

80° DIAMOND CHIP CONTROL
5 PC INSERT PACK W/ SCREWS - .156 IC
 FOR 3/16", 1/4" & 5/16" RIGHT HAND
 ACBC DIAMOND BORING BARS

FIVE SCREWS	"R" CORNER RADIUS	ORDER NUMBER		
		FIVE UNCOATED	FIVE ALTiN+	FIVE ZrCN
AT6+	0.003	ACD5031	ACD5031E	ACD5031Z
	0.007	ACD5071	ACD5071E	ACD5071Z
	0.015	ACD5151	ACD5151E	ACD5151Z

FIVE SCREWS	"R" CORNER RADIUS	ORDER NUMBER	
		FIVE UNCOATED	FIVE ALTiN+
AT6+	0.007	ACD507L2	ACD507L2E
	0.015	ACD515L2	ACD515L2E

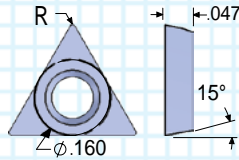

60° TRIANGLE FLAT TOP
5 PC INSERT PACK W/ SCREWS - .160 IC
 FOR 1/4" & 5/16" LEFT OR RIGHT HAND
 ACBT TRIANGLE BORING BARS

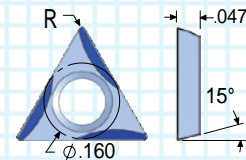

60° TRIANGLE CHIP CONTROL
5 PC INSERT PACK W/ SCREWS - .160 IC
 FOR 1/4" & 5/16" RIGHT HAND
 ACBT TRIANGLE BORING BARS

FIVE SCREWS	"R" CORNER RADIUS	ORDER NUMBER		
		FIVE UNCOATED	FIVE ALTiN+	FIVE ZrCN
AT6+	0.003	ATD5031	ATD5031E	ATD5031Z
	0.007	ATD5071	ATD5071E	ATD5071Z
	0.015	ATD5151	ATD5151E	ATD5151Z

FIVE SCREWS	"R" CORNER RADIUS	ORDER NUMBER	
		FIVE UNCOATED	FIVE ALTiN+
AT6+	0.007	ATD507L2	ATD507L2E
	0.015	ATD515L2	ATD515L2E

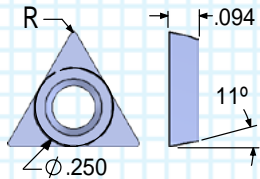

60° TRIANGLE FLAT TOP
5 PC INSERT PACK W/ SCREWS - .250 IC
 FOR 3/8" & 1/2" LEFT OR RIGHT HAND
 ACBT TRIANGLE BORING BARS

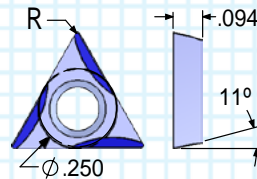

60° TRIANGLE CHIP CONTROL
5 PC INSERT PACK W/ SCREWS - .250 IC
 FOR 3/8" & 1/2" RIGHT HAND
 ACBT TRIANGLE BORING BARS

FIVE SCREWS	"R" CORNER RADIUS	ORDER NUMBER		
		FIVE UNCOATED	FIVE ALTiN+	FIVE ZrCN
AT8+	0.003	ATP2031	ATP2031E	ATP2031Z
	0.007	ATP2071	ATP2071E	ATP2071Z
	0.015	ATP2151	ATP2151E	ATP2151Z

FIVE SCREWS	"R" CORNER RADIUS	ORDER NUMBER		
		FIVE UNCOATED	FIVE ALTiN+	FIVE ZrCN
AT8+	0.007	ATP207L2	ATP207L2E	ATP207L2Z
	0.015	ATP215L2	ATP215L2E	ATP215L2Z

Bar to Insert Compatibility Chart - Right Hand

RIGHT HAND BARS FOR .156 IC DIAMOND SHAPED CARBIDE INSERTS

3/16" Bar Size	ACBC187FOR (07,07E,15,15E)	p.4
	ACBC187F5R (07,07E,15,15E)	p.4
	ACBC187R0R (07,07E,15,15E)	p.4
	ACBC187R5R (07,07E,15,15E)	p.4
1/4" Bar Size	ACBC250FOR (07,07E,15,15E)	p.6
	ACBC250F5R (07,07E,15,15E)	p.6
5/16" Bar Size	ACBC312FOR (07,07E,15,15E)	p.8
	ACBC312F5R (07,07E,15,15E)	p.8
1/2" Bar Size	ACBC187S4FOR (07,07E) STEP BAR	p.16

CORNER RADIUS
0.003
0.007
0.015

INSERT PACKS				
FLAT TOP			CHIP CONTROL	
FLAT TOP COATING OPTIONS			CHIP CONTROL COATING OPTIONS	
UNCOATED	ALTiN+	ZrCN	UNCOATED	ALTiN+
ACD5031	ACD5031E	ACD5031Z	N/A	N/A
ACD5071	ACD5071E	ACD5071Z	ACD507L2	ACD507L2E
ACD5151	ACD5151E	ACD5151Z	ACD515L2	ACD515L2E
INSERT PACKS LISTED ON PAGE 17				

RIGHT HAND BARS FOR .160 IC TRIANGLE SHAPED CARBIDE INSERTS

1/4" Bar Size	ACBT250FOR (07,07E,15,15E)	p.10
	ACBT250F5R (07,07E,15,15E)	p.10
	ACBT250R0R (07,07E,15,15E)	p.10
	ACBT250R5R (07,07E,15,15E)	p.10
5/16" Bar Size	ACBT312FOR (07,07E,15,15E)	p.12
	ACBT312F5R (07,07E,15,15E)	p.12
	ACBT312R0R (07,07E,15,15E)	p.12
	ACBT312R5R (07,07E,15,15E)	p.12
1/2" Bar Size	ACBT250S4FOR STEP BAR	p.16
	ACBT312S4FOR STEP BAR	p.16

CORNER RADIUS
0.003
0.007
0.015

INSERT PACKS				
FLAT TOP			CHIP CONTROL	
FLAT TOP COATING OPTIONS			CHIP CONTROL COATING OPTIONS	
UNCOATED	ALTiN+	ZrCN	UNCOATED	ALTiN+
ATD5031	ATD5031E	ATD5031Z	N/A	N/A
ATD5071	ATD5071E	ATD5071Z	ATD507L2	ATD507L2E
ATD5151	ATD5151E	ATD5151Z	ATD515L2	ATD515L2E
INSERT PACKS LISTED ON PAGE 17				

RIGHT HAND BARS FOR .250 IC TRIANGLE SHAPED CARBIDE INSERTS

3/8" Bar Size	ACBT375FOR (07,07E,15,15E)	p.14
	ACBT375R0R (07,07E,15,15E)	p.14
	ACBT375F5R (07,07E,15,15E)	p.14
	ACBT375R5R (07,07E,15,15E)	p.14
1/2" Bar Size	ACBT500FOR (BAR ONLY)	p.16
	ACBT500F5R (BAR ONLY)	p.16
	ACBT500R0R (BAR ONLY)	p.16
	ACBT500R5R (BAR ONLY)	p.16

CORNER RADIUS
0.003
0.007
0.015

INSERT PACKS				
FLAT TOP			CHIP CONTROL	
FLAT TOP COATING OPTIONS			CHIP CONTROL COATING OPTIONS	
UNCOATED	ALTiN+	ZrCN	UNCOATED	ALTiN+
ATP2031	ATP2031E	ATP2031Z	N/A	N/A
ATP2071	ATP2071E	ATP2071Z	ATP207L2	ATP207L2E
ATP2151	ATP2151E	ATP2151Z	ATP215L2	ATP215L2E
INSERT PACKS LISTED ON PAGE 17				

Bar to Insert Compatibility Chart - Left Hand

LEFT HAND BARS FOR .156 IC DIAMOND SHAPED CARBIDE INSERTS

3/16" Bar Size	ACBC187F0L (07,07E,15,15E)	p.5	CORNER RADIUS	INSERT PACKS			
	ACBC187F5L (07,07E,15,15E)	p.5		FLAT TOP			
	ACBC187R0L (07,07E,15,15E)	p.5		FLAT TOP COATING OPTIONS			
	ACBC187R5L (07,07E,15,15E)	p.5		UNCOATED	ALTIN+	ZrCN	
1/4" Bar Size	ACBC250F0L (07,07E,15,15E)	p.7		0.003	ACD5031	ACD5031E	ACD5031Z
	ACBC250F5L (07,07E,15,15E)	p.7		0.007	ACD5071	ACD5071E	ACD5071Z
5/16" Bar Size	ACBC312F0L (07,07E,15,15E)	p.9		0.015	ACD5151	ACD5151E	ACD5151Z
	ACBC312F5L (07,07E,15,15E)	p.9			INSERT PACKS LISTED ON PAGE 17		

LEFT HAND BARS FOR .160 IC TRIANGLE SHAPED CARBIDE INSERTS

1/4" Bar Size	ACBT250F0L (07,07E,15,15E)	p.11	CORNER RADIUS	INSERT PACKS			
	ACBT250F5L (07,07E,15,15E)	p.11		FLAT TOP			
	ACBT250R0L (07,07E,15,15E)	p.11		FLAT TOP COATING OPTIONS			
	ACBT250R5L (07,07E,15,15E)	p.11		UNCOATED	ALTIN+	ZrCN	
5/16" Bar Size	ACBT312F0L (07,07E,15,15E)	p.13		0.003	ATD5031	ATD5031E	ATD5031Z
	ACBT312F5L (07,07E,15,15E)	p.13		0.007	ATD5071	ATD5071E	ATD5071Z
5/16" Bar Size	ACBT312R0L (07,07E,15,15E)	p.13		0.015	ATD5151	ATD5151E	ATD5151Z
	ACBT312R5L (07,07E,15,15E)	p.13			INSERT PACKS LISTED ON PAGE 17		

LEFT HAND BARS FOR .250 IC TRIANGLE SHAPED CARBIDE INSERTS

3/8" Bar Size	ACBT375F0L (07,07E,15,15E)	p.15	CORNER RADIUS	INSERT PACKS			
	ACBT375R0L (07,07E,15,15E)	p.15		FLAT TOP			
	ACBT375F5L (07,07E,15,15E)	p.15		FLAT TOP COATING OPTIONS			
	ACBT375R5L (07,07E,15,15E)	p.15		UNCOATED	ALTIN+	ZrCN	
1/2" Bar Size	ACBT500F0L (BAR ONLY)	p.16		0.003	ATP2031	ATP2031E	ATP2031Z
	ACBT500F5L (BAR ONLY)	p.16		0.007	ATP2071	ATP2071E	ATP2071Z
1/2" Bar Size	ACBT500R0L (BAR ONLY)	p.16		0.015	ATP2151	ATP2151E	ATP2151Z
	ACBT500R5L (BAR ONLY)	p.16			INSERT PACKS LISTED ON PAGE 17		

SCT ADVANTAGE INDEXABLE TOOLING CATALOG



Scientific Cutting Tools, Inc.

805.584.9495

FAX 805.584.9629

800.383.2244

FAX 888.728.3295

sales@sct-usa.com

www.sct-usa.com

The SCT Guarantee

“Our pride in workmanship
assures product superiority every time.”

**SCAN
QR CODE
FOR FULL
SCT CATALOG**

