

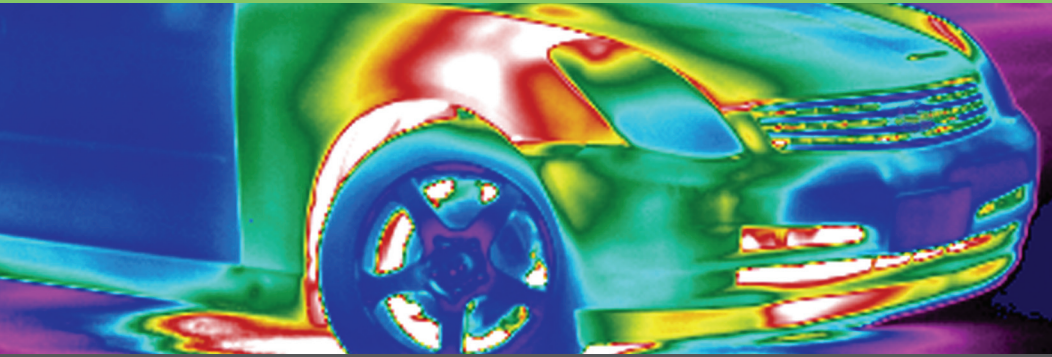

\$29.95



IR Automation Guidebook:
Temperature Monitoring and Control
with IR Cameras



IR Automation Guidebook: Temperature Monitoring and Control with IR Cameras

USA, Canada and Latin America

FLIR Systems Incorporated

America's Main Office, USA

Boston, MA

1-800-GO-INFRA (464-6372) or

1-978-901-8000

Europe, Middle East, Asia and Africa

FLIR Systems

International Main Office, Sweden

Tel: +32 3 287 87 10

The thoughts, ideas, opinions, and recommendations expressed in this book are intended for informational purposes only. FLIR accepts no liability for actions taken by readers in their individual businesses or circumstances.

Published by FLIR Systems Incorporated

This booklet may not be reproduced in any form without the permission in writing from FLIR Systems Incorporated.

www.goinfrared.com • 1 800 GO-INFRA

© Copyright 2008. All rights reserved.

Contents

Preface	iv
Chapter 1	
Typical Monitoring and Control Applications	1
Chapter 2	
Remote IR Monitoring	5
Chapter 3	
Temperature Measurement for Automated Processes	17
Chapter 4	
Combining Machine Vision and Temperature Measurement	25
Chapter 5	
Real-Time Control Issues	32
Appendix A	
Glossary	40
Appendix B	
Thermographic Measurement Techniques	43
Appendix C	
History and Theory of Infrared Technology	45
Appendix D	
Command Syntax Examples for A320 Resource Socket Services	58
Appendix E	
Quick Summary of FLIR IR Cameras	Inside Back Cover

Preface

Manufacturing and process engineers are under constant pressure to make production systems and processes more efficient and less costly. Frequently, their solutions use automation techniques to improve throughput and product quality. Automated IR (infrared) radiation imaging offers the potential for improving a host of industrial production applications, including process monitoring and control, quality assurance, asset management, and machine condition monitoring.

This handbook is intended to help those considering the creation or improvement of production automation or monitoring systems with IR cameras. Numerous application examples will be presented with explanations of how these IR vision systems can best be implemented.

Some of the major topics that will be covered include:

- Integration of IR cameras into automation systems
- Data communications interfaces
- Command and control of thermographic cameras
- Principles of thermographic measurements
- Interfacing with a PC or PLC controller
- Standard software packages for IR camera systems

These complex matters require attention to many details; therefore, this handbook cannot answer every question a system designer will have about the use of IR cameras in automated systems. It is meant to serve only as a roadmap through the major issues that must be faced in IR vision system design.

Typical Monitoring and Control Applications

Temperature Measurements with IR Cameras

Infrared (IR) radiation is not detectable by the human eye, but an IR camera can convert it into a visual image that depicts thermal variations across an object or scene. IR covers a portion of the electromagnetic spectrum from approximately 900 to 14,000 nanometers (0.9–14 μm). IR is emitted by all objects at temperatures above absolute zero, and the amount of radiation increases with temperature. A properly calibrated IR camera can capture thermographic images of target objects and can provide accurate non-contact temperature measurements of those objects. These quantitative measurements can be used in a variety of monitoring and control applications.

In contrast, other types of IR imagers provide only relative temperature differences across an object or scene. Hence, they are used to make qualitative assessments of the target objects, primarily in monitoring applications where thermal images are interpreted based on temperature contrast. One example is to identify image areas that correlate to physical anomalies, such as construction or sub-surface details, liquid levels, etc.

In some cases, an IR camera is justifiably referred to as a *smart sensor*. In these cases the IR camera has built-in logic and analytics that allows the comparison of measured temperatures with user-supplied temperature data. It also has a digital I/O interface so that a differential

temperature can be used for alarm and control functions. In addition, a smart IR camera is a calibrated thermographic instrument capable of accurate non-contact temperature measurements.

IR cameras with these capabilities operate much like other types of smart temperature sensors. They have fast, high-resolution A/D (Analog to Digital) converters that sample incoming data, pass it through a calibration function, and provide temperature readouts. They may also have other communication interfaces that provide an output stream of analog or digital data. This allows thermographic images and temperature data to be transmitted to remote locations for process monitoring and control.

Generally, smart IR cameras are used in quantitative applications that require accurate measurements of the temperature difference between a target object and its surroundings. Since temperature changes in most processes are relatively slow, the near-real-time data communications of smart IR cameras are adequate for many process control loops and machine vision systems.

Automation Applications

Typical automated applications using IR cameras for process temperature monitoring and control include:

- Continuous casting, extrusion, and roll forming
- Discrete parts manufacturing
- Production where contact temperature measurements pose problems
- Inspection and quality control
- Packaging production and operations

Chapter 1

- Environmental, machine, and safety monitoring
- Temperature monitoring as a proxy for other variables

The examples below demonstrate a wide range of applications that can be served with IR cameras. Potential applications are limited only by the imagination of the system designer.

Plywood Mill Machine Monitoring

Problem: Steam from open vats of hot water obscures the machinery operator's view of the logs as they are maneuvered for proper alignment in the log vat.

Solution: An IR camera can present an image to the operator that makes the cloud of steam virtually transparent, thereby allowing logs to be properly aligned in the log vat. This example of a qualitative application is illustrated in Figure 1.

Production Testing of Car Seat Heaters

Problem: Using contact temperature sensors to assure proper operation of optional car seat heaters slows down production and is inaccurate if sensors are not properly placed.

Solution: An IR camera can detect thermal radiation from the heater elements inside the seats and provide an accurate non-contact temperature measurement.

This quantitative measurement can be made with a camera that is permanently mounted on a fixture that is swung into measurement position when the car reaches a designated point on the assembly line. A monitor near that position provides an image with a temperature scale that reveals the temperature of the car seat heater elements, as shown in Figure 2.



Figure 1. Plywood mill application

Typical Monitoring and Control Applications

Packaging Operations

Problem: On a high-speed packaging line, efficient methods for non-destructive testing of a glued box seal are scarce, and most tend to be very cumbersome. In addition, the glue

application method has a good deal of variability that must be monitored and recorded with statistical quality control routines.

Solution: Since the glue is heated prior to application, its temperature and



The Problem

- Optional features in vehicles cannot be inspected without some type of contact.
- This slows down production.
- 100% inspection is tedious.

The Solution

- An IR camera can be permanently mounted to inspect these items.
- An IR camera can be used in a non-contact method.

Figure 2. Production testing of car seat heater elements

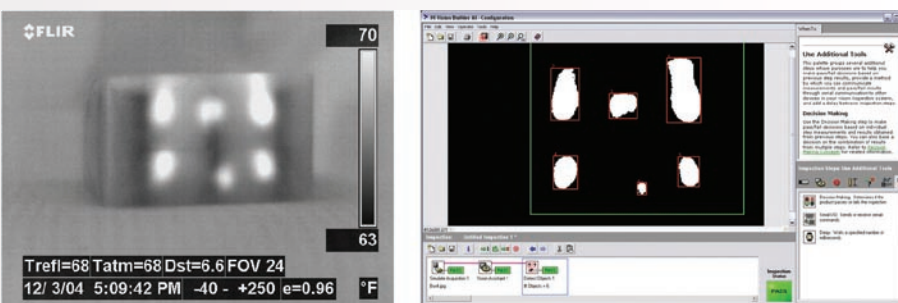

The Problem

- Detect incorrectly sealed boxes.
- Remove failed units from the line.
- Generate an alarm if too many boxes fail.
- Log statistical data of pass/fail.

The Solution

- Capture a thermal image of the box.
- Detect presence of glue spots.
- Pass/fail on each box.
- Log statistics.

Figure 3. Machine vision box seal quality control

➤ Chapter 1

locations on the box lid can be monitored with an IR camera. Moreover, the image can be digitized in a way that allows this information to be stored in a statistical quality control database for trend analysis and equipment monitoring as shown in Figure 3.

This is an example of using differential temperature as a proxy for another variable. In this case, temperature replaces mechanical methods of inspection/testing.

Summary

The automation examples presented in this chapter have barely scratched the surface of the application space

that smart IR cameras can serve. In the following chapters, more detailed examples will be presented along with practical information on the implementation of automated systems that exploit the advantages of IR cameras. These chapters are organized according to the major types of applications that typically use IR cameras:

- Remote thermographic monitoring
- Non-contact temperature measurement for automated processes
- Combining IR machine vision with temperature measurement
- Real-time control and monitoring – issues and answers

Remote IR Monitoring

Overview

Infrared radiation is emitted by all objects at temperatures above absolute zero and is detectable by IR cameras. Since these cameras have various means of communicating thermographic images and temperatures to remote locations, they are ideal for remote and unattended monitoring. Moreover, smart IR cameras (those with built-in logic, analytics, and data communications), can compare the temperatures obtained from their thermographic images with user-defined settings. This allows the camera to output a digital signal for alarm and control purposes, while also providing live images.

IR Camera Operation

IR camera construction is similar to a digital video camera. The main components are a lens that focuses IR onto a detector, plus electronics and software for processing and displaying thermographic images and temperatures on an LCD or CRT monitor (Figure 1). Instead of a charge coupled device that video and digital still cameras use, the IR camera detector is a focal plane array (FPA) of micrometer size pixels made of various materials sensitive to

IR wavelengths. FPA resolution ranges from about 80×80 pixels up to 1024×1024 pixels. In some IR cameras, the video processing electronics include the logic and analytical functions mentioned earlier. Camera firmware allows the user to focus on a specific area of the FPA or use the entire detector area for calculating minimum, maximum, and average temperatures. Typically, temperature measurement precision is $\pm 2^{\circ}\text{C}$ or better.

The camera lens and distance to the target object results in a field of view (FOV) that determines the spot size covered by each pixel. The pixel's analog output represents the intensity of heat energy received from the spot it covers on the target object. In FLIR IR cameras, the A/D converters that digitize the pixel output have resolutions that range from 8 bits (2^8 or 0–255 pixels) up to 14 bits (2^{14} or 0–16383 pixels). The thermographic image seen on the monitor screen is the result of a microprocessor mapping these pixel output values to a color or gray scale scheme representing relative temperatures. In addition, radiometric information associated with the heat energy impinging on a pixel is stored for use in calculating the precise temperature of the spot covered by that pixel.

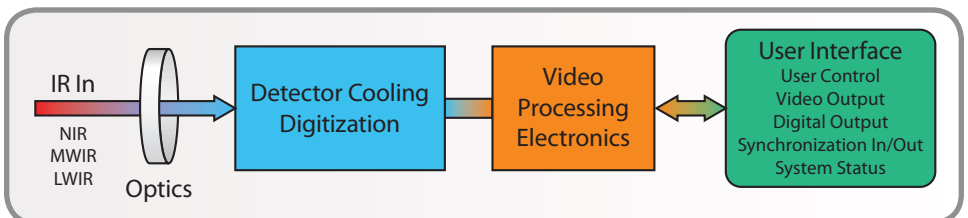

Figure 1. Simplified block diagram of an IR camera

Hence, IR cameras with these capabilities operate much like other types of smart temperature sensors. Their calibrated outputs can be accessed via one or more communication interfaces and monitored at a remote location. Images saved from these cameras are fully radiometric¹ and can be analyzed off-line with standard software packages, such as those available from FLIR.

Important Criteria in Remote Monitoring Systems

When considering an IR camera for a remote monitoring system, some of the important variables to consider are:

- Spot size – the smallest feature in a scene that can be measured
- FOV (Field of View) – the area that the camera sees
- Working distance – distance from the front of the camera lens to the nearest target object
- Depth of field – the maximum depth of a scene that stays in focus
- Resolution – the number of pixels and size of the sensor's active area
- NETD (Noise Equivalent Temperature Difference) – the lowest level of heat energy that can be measured
- Spectral sensitivity – portion of the IR spectrum that the camera is sensitive to
- Temperature measurement range, precision, and repeatability – a function of overall camera design

Another fundamental consideration is which portion of a camera's FOV contains the critical information required for monitoring purposes. The objects within the FOV must provide an accurate indication of the situation being monitored, based on the temperature of those objects. Depending on the situation, the target objects may need to be in the same position consistently within the camera's FOV. Other application variables related to the monitored scene include:

- Emissivity of the target objects
- Reflected temperatures within the FOV
- Atmospheric temperature and humidity

These topics will be covered in more detail in a subsequent chapter.

Remote Asset Monitoring

One type of application where IR cameras are very useful is in remote monitoring of property, inventory, and other assets to help prevent loss and improve safety. Frequently, this involves storage facilities, such as warehouses or open areas for bulk materials. The following example can serve as a general model for setting up an IR camera monitoring system for this type of application.

Hazardous Waste Storage Monitoring. In this application barrels of chemical waste products are stored in a covered facility, but one in which they cannot be totally protected from moisture. Thus, there is the possibility of leaks or barrel contents becoming contaminated by air and moisture, causing a rise in temperature due to a chemical reaction. Ultimately, there is a risk of fire, or even an explosion.

¹ Radiometry is a measure of how much energy is radiating from an object, as opposed to thermography, which is a measure of how hot an object is; the two are related but not the same.

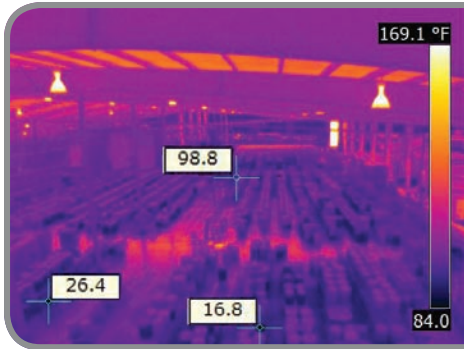

Figure 2a. IR image of a hazardous waste storage area showing two spot temperature readings (26.4°F and 16.8°F) that are in the safe range, plus one reading (98.8°F) that is abnormally high.



Figure 2b. A subsequent image of the same area shows that the abnormal reading in 2a has increased further, causing an alarm to go off.

While visible light cameras might be used in such an application, there often is a line-of-sight problem where many of the barrels cannot be seen, even with multiple cameras positioned throughout the storage area. In addition, smoke or flames would have to be present before a visible light camera could detect a problem. This might be too late for preventative measures to be taken. In contrast, stand-alone IR cameras monitoring the facility can detect a temperature rise within their FOV before fire occurs (Figures 2a and 2b).

Depending on the camera manufacturer, several monitoring options are available. For instance, the FLIR A320 camera allows a threshold temperature value to be set internally for alarm purposes. In addition, the camera's logic and clock functions can be configured so that a rise in temperature must be maintained for a certain period of time before an alarm is sent. This allows the system to ignore a temporary temperature rise in a camera's FOV caused by a forklift entering the area

to add or remove barrels. Furthermore, a hysteresis function can also be used to prevent an alarm from turning off until the detected temperature falls well below the setpoint (Figure 3).

Cameras with a digital I/O interface typically provide an OFF/ON type of output for alarm purposes. The digital I/O output is either off or on; when on, it is typically a DC voltage or current. For example, the digital I/O output from a FLIR A320 camera is 10–30VDC for loads of 100mA or less. Typically, the digital I/O output is sent to a PLC (Programmable Logic Controller) that controls the portion of an alarm system associated with the monitored area.

A good way to set up the alarm system is to have all cameras configured so they have a high level digital output when the temperature is below the alarm condition that holds a PLC in its non-alarm state. When the alarm setpoint temperature is detected, the camera's digital I/O output goes low (typically zero volts) after an appropriate time delay, causing the PLC

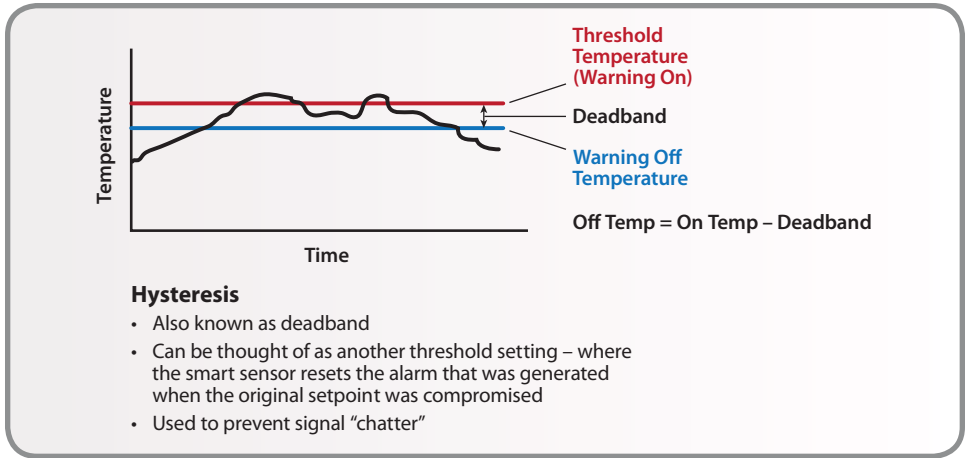

Figure 3. Hysteresis is an important signal processing characteristic of smart IR cameras, which makes monitoring and control functions much more effective.

to go into its alarm state. This creates a fail-safe system. If power to the camera is lost, then there is no high level output to the PLC, which treats that event just as if a temperature had reached the setpoint, thereby causing an alarm. This alerts personnel that they have either lost the monitoring function or there is indeed a temperature rise.

Image monitoring. Receiving a warning based on temperature measurements is very useful, but the real power of IR-based asset monitoring is in the camera’s image processing capabilities. Control room personnel can get live images from IR cameras that visible light cameras and other temperature detectors cannot provide. Again, cameras vary by manufacturer, but the most versatile ones offer a variety of data communication formats for sending thermographic images to remote locations. Increasingly, web-enabled cameras are used to allow

monitoring from any location where a PC is available.

Figure 4 illustrates a system using the FLIR A320’s Ethernet and TCP/IP communication protocols in conjunction with its alarm setpoint capabilities. The Ethernet portion of the system allows cable runs of up to 100 meters in length. By communicating a digital alarm directly to the PLC, it can immediately activate a visual and/or audible alarm. The visual alarm can appear on an annunciator panel telling the operator where the alarm originated; the operator then goes to the PC to look at live image(s) of that location. Images and temperature data can be stored for future reference and analysis.

A320 cameras can also be configured to automatically send temperature data and images to a PC via e-mail (SMTP) or FTP protocol whenever the temperature setpoint is reached, thereby creating a record for subsequent review.

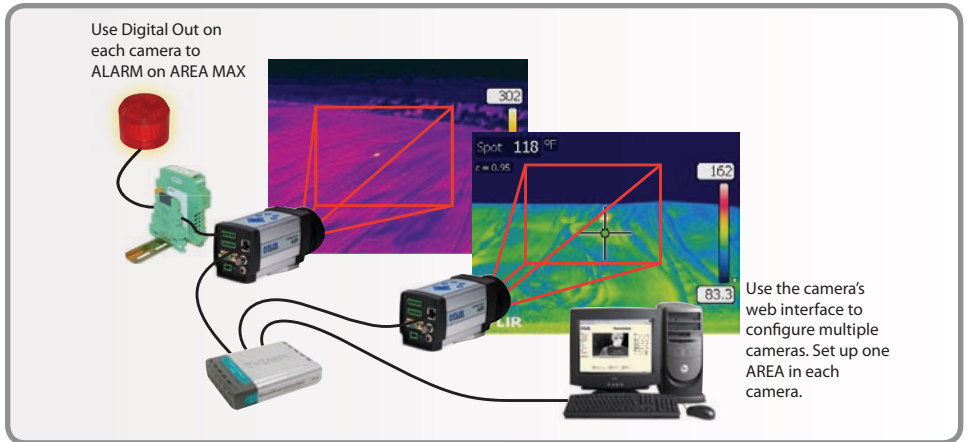

Figure 4. An example of one type of system configuration for remote IR camera monitoring. The system uses a digital alarm output for annunciating an over-temperature condition and transmits streaming MPEG-4 compressed video that allows the scene to be viewed on a PC monitor.

In conjunction with a host controller running FLIR's IR MONITOR (or other suitable software), temperature data can be captured for trend analysis. The A320 can also supply a digital compression of the camera's analog video signal, which can be sent as MPEG-4 streaming digital video over an Ethernet link to a PC monitor. IR MONITOR can be used to set up temperature measurements, image capture, and camera display functions. This application allows the PC to display up to nine camera images at a time and switch between additional camera groups as needed. The FLIR IP CONFIG software can be used to set up each camera's IP address.

After the cameras are configured, the PC used for monitoring does not need to remain on the network continually. By using the FTP and SMTP protocols within the camera, the user can receive radiometric images upon alarm events or on a time based schedule. Also, any

available PC with a web browser can be used to access the cameras web server for live video and basic control. This web interface is password protected.

Most IR cameras have an analog video output in a PAL or NTSC format. Therefore, another image monitoring possibility is to use a TV monitor to display thermographic video. A single control room monitor can be used with a switch to view live images from each camera sequentially. When the cameras are properly configured, control room personnel can view scaled temperature readings for any point or area (minimum, maximum, and average) in that image. (See color scales in the screen capture images depicted in Figure 2.) Not only will the operator know when there is excessive heat, he or she can see where it is.

Another example of the innovative functions available in camera firmware or external software is a feature called

Chapter 2

image masking. This enables the user to pre-select specific areas of interest for analysis of temperature data. This is illustrated in Figure 5, which shows continuous monitoring of substation hotspots that indicate problem areas.

A similar type of pattern recognition software can be used for automated inspection in metal soldering and welding and in laser welding of plastic parts. IR cameras can see heat conducting through the finished parts to check the temperature of the areas where parts are joined together against a stored value. In addition, the software can learn a weld path to make sure this path is correct, which is accomplished by programming the specific pixels in an image to be used by the software for this purpose. Alternatively, the program

developer can save an image of a “perfect” part and then have the software look for minimum, maximum, or delta values that tells the equipment operator if a part passes inspection. The car seat heater inspection described in Chapter 1 can be an example of this, and the same principle is used in the inspection of car window heater elements by applying power to them and looking at their thermographic image.

Power over Ethernet. It should be noted that a camera with Ethernet connectivity can be powered from a variety of sources, depending on its design. Typically, a connection for an external DC supply is used, or where available, the camera is powered via PoE (Power over Ethernet). PoE uses a power supply connected to the network with spare signal leads not

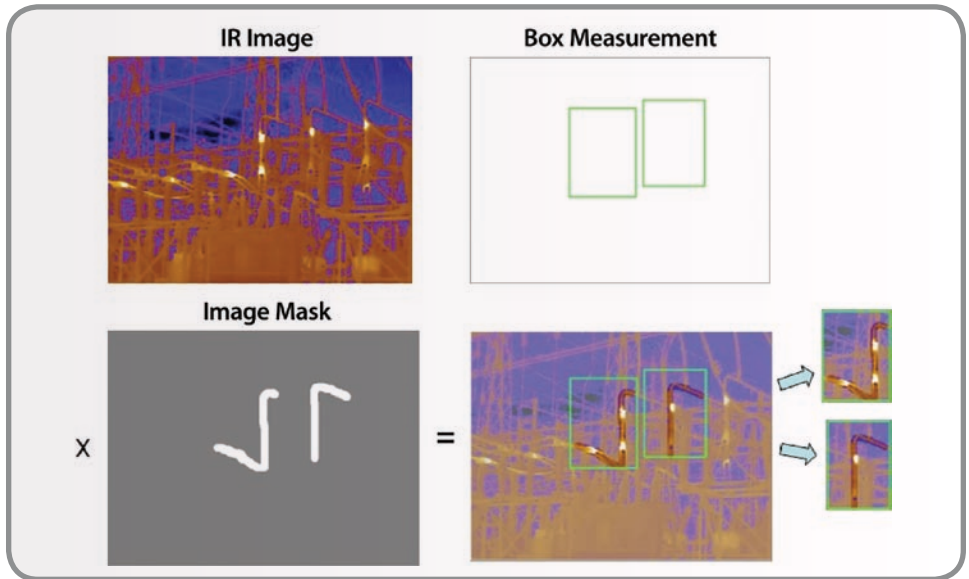

Figure 5. Masking functionality of the FLIR A320 IR camera, which is also available in some third party software programs.

otherwise used in 10/100baseT Ethernet systems. Various PoE configurations are possible. Figure 6 depicts one in which the power source is located at one end of the network. (Gigabit Ethernet uses all available data pairs, so PoE is not possible with these systems.)

PoE eliminates the need for a separate power source and conduit run for each camera on the network. The only additional cost is for some minor electrical hardware associated with PoE.

Many applications encompass areas that exceed the maximum Ethernet cable run of 100m. In those cases, there are wireless and fiberoptic converter options that provide off-the-shelf solutions for communicating over much greater distances. These are frequently used in the bulk material storage applications described below.

Additional Asset Monitoring Situations

Bulk Material Storage. Many bulk materials are stored in open yards where air and moisture can help promote decomposition and other exothermic reactions that raise the temperature of the pile. This brings with it the threat of fire, direct monetary loss, and safety issues for personnel. In addition, there is the risk of consequential damages caused by fires, including loss of nearby property, water damage resulting from fire-fighting, and production shutdowns. Materials that are especially prone to spontaneous combustion include organic wastes (compost, etc.), scrap paper for recycling, wood, coal, and various inorganic chemicals, such as cement and chlorine hydrates. Even in the absence of spontaneous combustion, many bulk materials like plastics pose a fire hazard due to sparks or other external ignition sources.

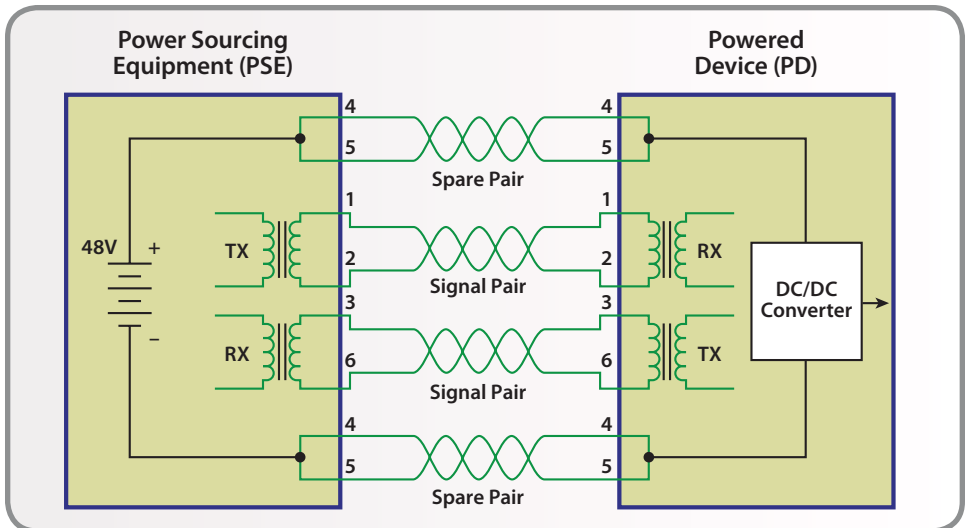

Figure 6. Schematic depicting spare-pair PoE delivery using the endpoint PSE arrangement.

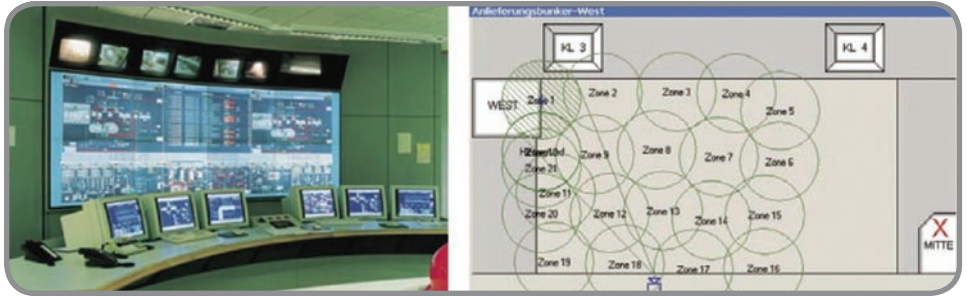

Figure 7. Control room for waste pile processing, and screen capture of the zone monitoring layout, which uses a FLIR IR camera on a pan-tilt mount for fire hazard warning.

In most cases, prevention is less costly than a cure, and the best prevention is continuous monitoring of the materials. The cost of an automated temperature monitoring system using IR cameras is a modest and worthwhile investment. System design can take the same form as the one described earlier for hazardous waste barrels. Cameras are configured to generate a direct alarm output to an operator when user-defined maximum temperature thresholds are exceeded. Audible and visual alarms in a control room draw the operator's attention to a possible spontaneous fire development. Various types of software have been developed to isolate trouble spots, such as the waste pile zone monitoring system depicted in Figure 7.

Although self-ignition usually starts within the bottom layers of a stock pile, continuous monitoring of the surface reveals hot spots at an early stage (Figure 8), so measures can be taken to prevent a major fire from breaking out. Large storage yards generally require multiple cameras for total coverage, with the cameras mounted on metal masts above the stock piles. This calls for cameras with housings and other features designed

for reliable operation in harsh industrial environments.

Critical Vessel Monitoring (CVM). There are several applications where the temperature of a vessel and its contents are critical. The vessels could be used for chemical reactions, liquid heating, or merely storage. For large vessels, the use of contact temperature sensors poses problems. One reason could be non-uniform temperatures throughout a vessel and across its surface. This would require a large number of contact type sensors, whose installations can become quite costly.

For most CVM applications, a few IR cameras can image nearly 100% of a vessels surface (Figure 9). Moreover, they can measure the surface temperature of the CVM to trend and predict when the internal refractory will break down and compromise the mechanical integrity of the system. If specific regions of interest (ROIs) must be focused on, IR camera firmware (or external PC software) allows the selection of spot temperature points or areas for measurement.

Again, some variation of the systems described earlier can be used. Depending

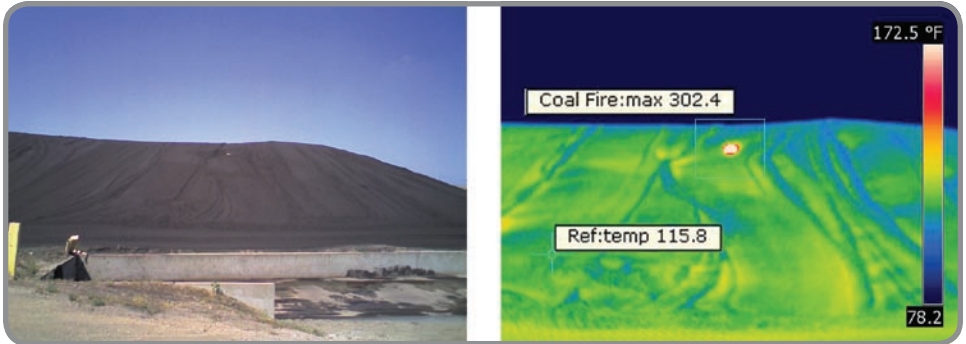

Figure 8. Visible light and IR images of a coal pile – the thermographic image clearly identifies a hot spot that is a fire about to erupt.

on the application environment, an explosion proof housing for the camera may be a requirement. HMI (human-machine interface) software, such as SCADACAM iAlert from Pivotal Vision, can be used to provide a monitoring overview. This has the ability to combine all of the camera images into a single spatial representation of the monitored area – in this case, a flattened-out view of the vessel. This view can be updated continuously for a near-real-time thermographic representation.

Electrical Substation Monitoring. Reliable operation of substations is crucial for uninterrupted electrical service. Besides lightning strikes and large overloads, aging equipment and connections are a major cause of infrastructure failures and service interruptions. Many of these failures can be avoided with effective preventative maintenance monitoring. Often, the temperatures of transformers, breakers, connections, etc. will begin to creep up before a catastrophic failure occurs. Detection of these temperature increases with IR cameras allows preventative maintenance operations

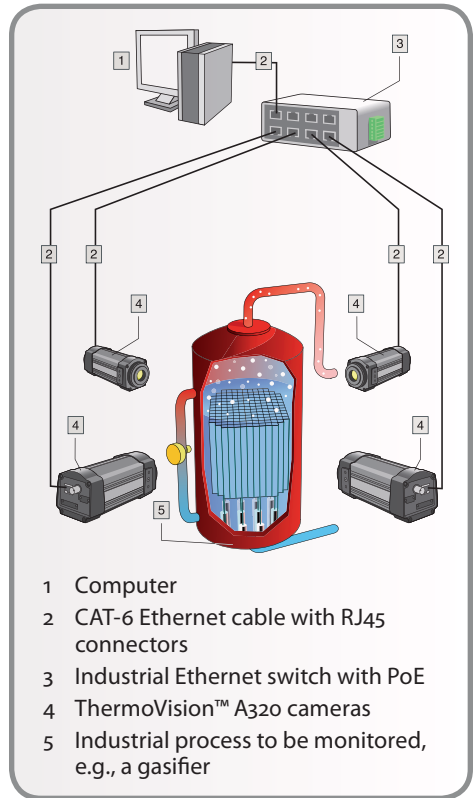

Figure 9. CVM monitoring example showing camera locations, network connections, and PC.



Figure 10. Visible light and IR images of a substation showing a transformer with excessive temperature.

before an unplanned outage happens. (See Figure 10.)

The cameras can be installed on a pan/tilt mounting mechanism to continually survey large areas of a substation (Figure 11). A few cameras can provide real-time coverage of all the critical equipment that should be monitored. In addition to preventative maintenance functions, these cameras also serve as security monitors for intrusion detection around the clock.

By combining the cameras' Ethernet and/or wireless connectivity with a web-enabled operator interface, live images can be transmitted to utility control rooms miles away. In addition, trending software can be used to detect dangerous temperature excursions and notify maintenance personnel via email and snapshot images of the affected equipment.

These features and functions are already in place at leading utility companies in the U.S., such as Exel Energy's "Substation of the Future." Companies such as

Exel consider IR monitoring a strategic investment in automation, which is part of a common SCADA (Supervisory Control And Data Acquisition) platform for maintenance and security operations. The most advanced systems provide time-stamped 3-D thermal modeling of critical equipment and areas, plus temperature trending and analysis. A company-wide system of alerts provides alarms on high, low, differential, and ambient temperatures within or between zones in real time.

The previous examples represent just a few applications that can benefit from remote IR camera monitoring. A few other applications where IR temperature monitoring is being used include:

- Oil and gas industries (exploration rigs, refineries, flare gas flues, natural gas processing, pipelines, and storage facilities)
- Electric utilities (power generation plants, distribution lines, substations, and transformers)



Figure 11. Example pan/tilt mounting system.

Chapter 2

- Predictive and preventative maintenance (continuous/fix position monitoring of critical equipment)

Besides these, there are many qualitative remote monitoring applications where imaging is the predominant feature. For example, IR cameras can be used as part of an early warning system for forest fires (Figure 12), detecting blazes before significant amounts of smoke appear. Another example is using IR imaging to look through condensation vapor that would otherwise obscure an operator's view of equipment and processes. This is being used in coking plants, veneer mills, and plywood log handling operations, among others (see Chapter 1, Figure 1).

Summary

As noted in the text, IR camera temperature data may be used for

qualitative monitoring or for quantitative temperature measurement and control. In the former, thermal images are obtained and interpreted based on temperature contrast. It can be used to identify image areas that correlate to sub-surface details, liquid levels, refractory, etc.

Quantitative measurements generally require the IR camera to accurately determine the temperature difference between the target object and its surroundings. In remote monitoring, this allows the temperature data to be used for alarm purposes or to even shut down equipment. Since temperature changes slowly in many situations, the near-real-time data communications of smart IR cameras are more than adequate for alarm and control systems.

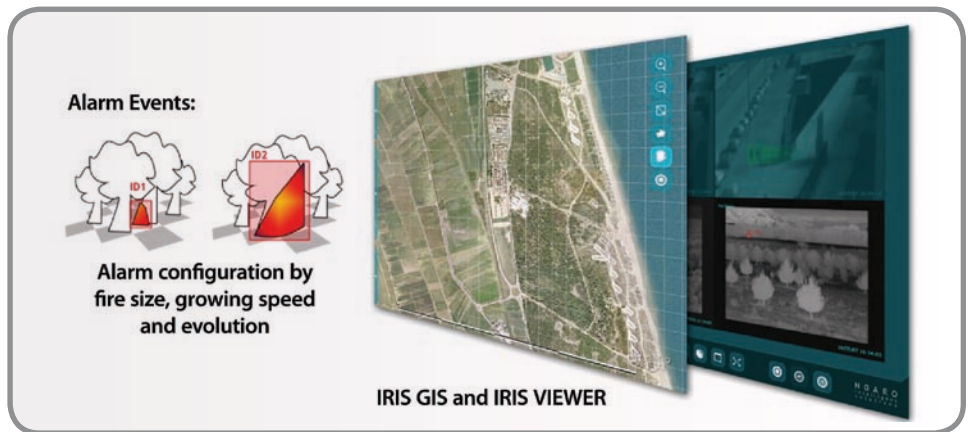

Figure 12. Ngargo's IRIS® Watchman forest fire early warning system uses a FLIR IR camera.

Temperature Measurement for Automated Processes

Background

In Chapter 2 the emphasis was on specific applications where a single temperature threshold is programmed into an IR camera, and when the threshold is reached an alarm is triggered through a PLC. Multiple cameras are often required, but viewing an IR camera's thermographic image is a secondary consideration – to verify an alarm condition. Chapter 3 focuses on applications where multiple temperatures within a single camera's FOV are important, and that information is used for some sort of process control function. In these applications, the camera is typically integrated with other process control elements, such as a PC or PLC using third party software and more sophisticated communication schemes.

Typical Camera Measurement Functions

Many IR cameras provide the user with different operating modes that support correct temperature measurements under various application conditions. Typical measurement functions include:

- Spotmeter
- Area
- Image mask
- Delta T
- Isotherm
- Temperature range
- Color or gray scale settings

The last two are used with the others to provide a visual indication of the range of temperatures in the camera's FOV. Generally, spot and area temperatures tend to be the most useful in monitoring and control applications, and most cameras allow multiple spots or areas to be set within the thermographic image. For example, the FLIR A320 camera supports up to four spots and four areas.

Cursor functions allow easy selection of an area of interest, such as the crosshairs of the spot readings in Figure 1. In addition, the cursor may be able to select circular, square, and irregularly shaped polygon areas.

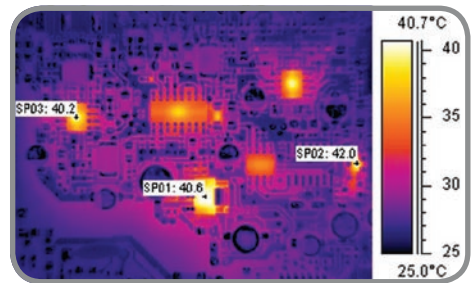

Figure 1. IR image of a printed circuit board indicating three spot temperature readings. Image colors correspond to the temperature scale on the right.

The spotmeter finds the temperature at a particular point. The area function isolates a selected area of an object or scene and may provide the maximum, minimum, and average temperatures inside that area. The temperature measurement range typically is selectable by the user. This is a valuable feature when a scene has a temperature range narrower than a camera's full-scale range. Setting a narrower range allows better resolution of the images and higher accuracy in the measured

Chapter 3

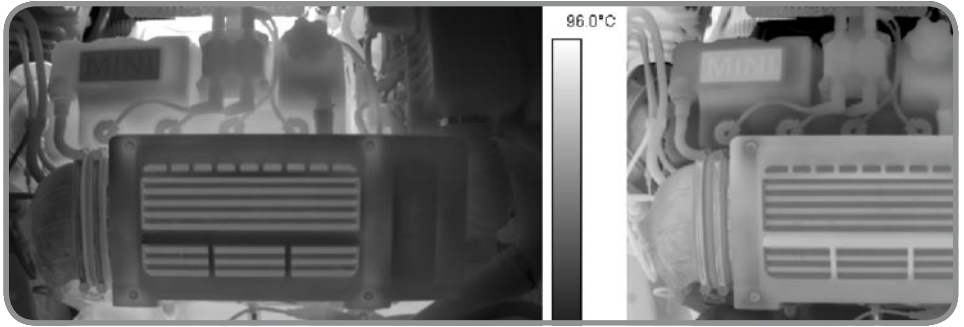

Figure 2. Gray scale images of a car engine – the left view has white as the hottest temperature and the right view shows black as the hottest.

temperatures. Therefore, images will better illustrate smaller temperature differences. On the other hand, a broader scale and/or higher maximum temperature range may be needed to prevent saturation of the portion of the image at the highest temperature.

As an adjunct to the temperature range selection, most cameras allow a user to set up a color scale or gray scale to optimize the camera image. Figure 2 illustrates two gray scale possibilities.

In Figure 1, a so-called “iron scale” was used for a color rendering. In a manner similar to the gray scale above, the hottest temperatures can be rendered as either lighter colors or darker colors. Another possibility is rendering images with what is known as a rainbow scale (Figure 3).

While choice of color scale is often a matter of personal preference, there may be times when one type of scale is better than another for illustrating the range of temperatures in a scene.

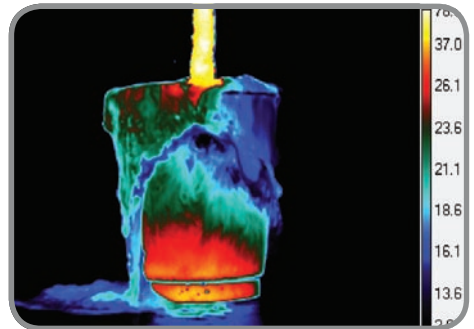

Figure 3. Rainbow scale showing lower temperatures towards the blue end of the spectrum.

Application Examples

Go/No-Go. In these applications, one or more temperatures are monitored to make sure they meet process criteria, and machinery is shut down or product rejected when a measured temperature goes above or below the setpoint. A good example of this is a manufacturer of automotive door panels that uses IR cameras to monitor and measure part temperatures prior to a molding procedure.

Temperature Measurement for Automated Processes

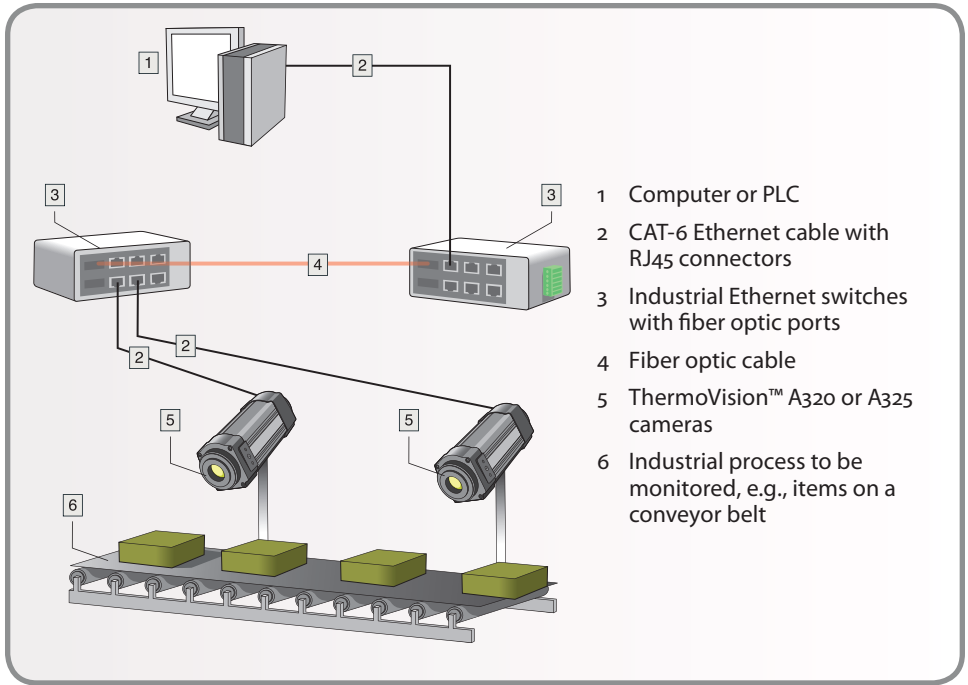

Figure 4. Typical Go/No-Go QC inspection system using IR cameras.

This process starts with reinforcing parts that have been stored in a warehouse. In either the warehouse or during transport to the molding line, these parts can become wet due to moisture condensation or exposure to inclement weather. If that happens, they may not reach a high enough temperature in the molding press and finished panels will be of poor quality.

The parts go into the press two at a time from a conveyor where they are sealed together and the finished door panel is molded into the required shape for a specific car model. If the parts are wet, this creates steam in the press and causes mold temperature to be too low.

However, it was found that movement of wet parts on the conveyor causes their temperature to be lower than normal. So, just before the parts go into the press, the conveyor stops and an IR camera makes a non-contact measurement of their temperature. The diagram in Figure 4 is typical for this type of quality control application.

The IR camera's area tools are applied to the thermographic image to check for the minimum allowable temperature of the two parts. If either temperature is below the setpoint (typically, the ambient temperature), then a digital I/O output to a PLC causes an alarm to be sounded and

Chapter 3

the molding line is halted so the parts can be removed.

For OEMs, preventing bad panels from getting to the end product avoids a potential loss of business. Warranty replacement of a door panel after an end customer takes possession of the car is an expensive proposition for the OEM.

The trick is to make sure the camera is measuring the temperature of the parts and not the floor beneath the conveyor, which is within the camera's FOV and typically much cooler. This occurs when the parts are not in the proper position. A photoelectric detector tells the PLC when the parts enter the press area; otherwise its ladder logic ignores the alarm output from the camera.

Continuous Process Monitoring.

Temperature is an important variable in many processes. It can either be an integral part of a process or act as a proxy for something else. The following describes an example that encompasses both of these situations.

Artificial fiber production typically involves a continuous extrusion process. Multiple strands may be extruded simultaneously or, in the case of non-woven sheets, a web process may be involved. In either case, monitoring the temperature of the material as it comes out of the extruder can detect strand breakage or material blockage and backup in the process. Using an IR camera for unattended monitoring can catch these malfunctions early, before a huge mess is created that causes a long machinery outage and costly production losses. In addition, the actual

temperature readings can be used for trend analysis.

Depending on the application, either the spot or area measurement functions of the camera can be used. In the latter case, it is likely that the application would take advantage of all the area measurement capabilities – minimum, maximum, and average temperatures of the defined area. If any of these were to fall outside the user-defined limits, the application program running on a PC or PLC could instantly shut down the process machinery.

In one such application, FLIR customized the camera firmware to allow simultaneous monitoring of up to 10 different areas. Figure 5 shows a monitored area covering six fiber strands coming out of the extruder, along with an alarm setpoint temperature in the upper left corner.

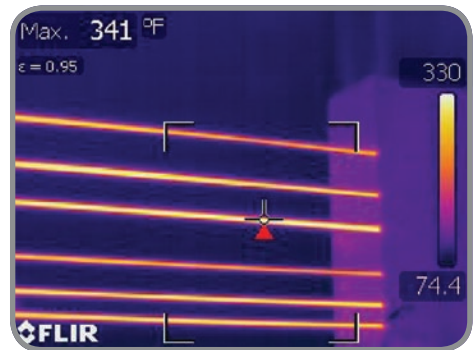

Figure 5. Monitoring of artificial fibers coming out of an extruder.

As in the case of many remote monitoring applications, the user may choose to route the camera's analog video to a control room monitor. For cameras with an Ethernet connection, digitally

Temperature Measurement for Automated Processes

compressed (MPEG-4) streaming video can be available for monitoring on a PC screen. With FLIR's A320 camera, images and alarms can be sent to a remote PC via TCP/IP and SMTP (email) protocols.

While a visible light camera may be able to detect broken fiber strands, an IR camera can also provide temperature measurements for trending and statistical process control (SPC) purposes. In addition, some textile processes create steam or condensation vapors that a visible light camera cannot see through, but an IR camera can. Thus, an IR camera provides multiple functions and is more cost effective.

Data Communications and Software Considerations

Different cameras have different video frame rates. The frame rate governs how frequently the thermographic image and its temperature data are updated. A typical rate might be every zooms or so. The camera's digital communications protocol could create a small amount of additional latency in the update process. Still, because process temperatures tend to change slowly, collecting temperature data at this rate provides a wealth of information for quality control purposes.

In many IR cameras there is some sort of serial/socket interface that can be used for communications with the PC or PLC that is running a control script, or application. When a system designer or user is most familiar with PLCs, the control algorithm can be built around a virtual PLC created on a PC, which emulates actual PLC hardware and logic. In any case, a human-machine interface (HMI) is created to monitor data coming

from the camera. The details described below are based on FLIR's A320 camera, but should be representative of most cameras that transmit data over an Ethernet link.

The only physical interface for digital data transfer from the FLIR A320 is the Ethernet port. Only TCP/IP is supported, but the camera should work seamlessly on any LAN when the proper IP address, netmask, and possibly a gateway is set up in the camera. The two main ways of controlling the camera are through the command control interface and the resource control interface. Digital image streaming, data file transfer, and other functionality is provided through the IP services interface. A lot of software functionality is exposed through software resources. These resources can be reached through the FLIR IP Resource Socket Service. This is the camera's resource control (serial/socket) interface. Independent of the physical Ethernet interface, it is possible to access the camera system using TCP/IP with telnet, ftp, http, and FLIR Resource Socket Services (among others).

Most PLCs provide serial/socket interfaces for Ethernet. One example is Allen-Bradley's EtherNet/IP Web Server Module (EWEB for short). Another example is HMS Industrial Network's Anybus X-Gateway Ethernet interface module, which can convert this serial socket interface to many industrial network protocols, such as EtherNet I/P, Modbus-TCP, Profnet, Ethernet Powerlink, EtherCAT, FLNet., etc.

Camera setup and data acquisition is normally done directly through the FLIR IR MONITOR and IP CONFIG software running on a PC. Afterward, the camera can be

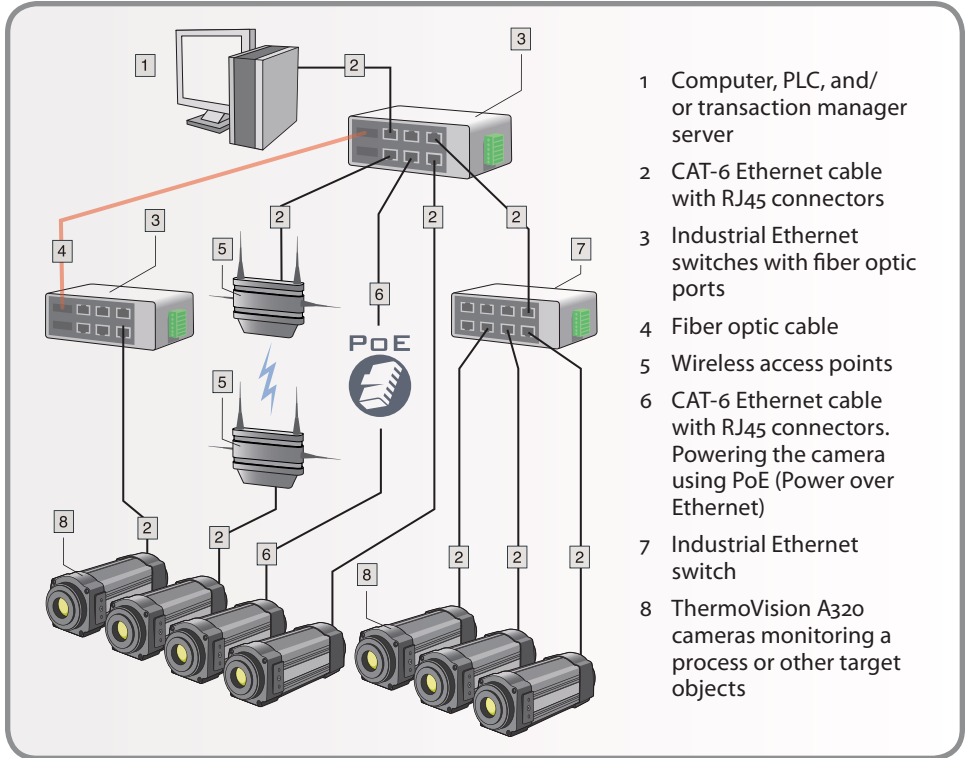

Figure 6. Generalized IR machine vision system and its communications network

connected on the network for continuous monitoring and data logging via PC or PLC control. Typically, the telnet protocol, accessed by the Windows® PC running the application program, is used to query the camera for data. This protocol is also available for most PLCs. In either case, this takes place through the camera's Resource Socket Services. (Command syntax is contained in the camera's ICD manual; a few examples are listed in Appendix D.)

The system designer or FLIR would create the message instructions that allow the PLC to query the camera for temperature data and thermographic

images in the same way it is done with PC control. Alternatively, the PLC can hold the Ethernet port open and call for the camera to continuously output data to this port at the maximum rate possible. In either case, alarm functions and decision-making is performed by the application program running on the PLC (or PC if applicable). (See Figure 6.) Typically, temperatures and images collected for trend analysis and statistical process control purposes are stored on a separate server connected to the network, which is running transaction manager software for downloading and storing data.

Inspect Faster

with NI Vision Builder AI



National Instruments Vision Builder for Automated Inspection (AI) now features an innovative state machine editor, taking you from initial design to deployed vision application faster than ever. Easily integrate with existing industrial control hardware – no programming required.

NEW! Vision Builder AI

- Configurable Machine Vision
- No Programming Required
- Acquisition from Thousands of Cameras

>> Get your free 30-day trial version
at ni.com/vision/vbai

800 891 8841



©2008 National Instruments Corporation. All rights reserved. National Instruments, NI, and ni.com are trademarks of National Instruments. Other product and company names listed are trademarks or trade names of their respective companies. 2008-9522-221-101

Figure 7. Example of a control and data acquisition option for IR cameras

➤ Chapter 3

For system developers who are writing or modifying code with Visual Basic, C++, etc. for customized applications running on a PC, there are a few options. FLIR's Researcher package supports OLE-2, the Microsoft standard for linking and embedding data between applications. Image and temperature data can be linked from Researcher into other compliant applications, such as Excel. The linked data updates automatically, so if a temperature value changes in Researcher it will automatically change in the linked application. In addition, Researcher provides an automation interface that can be used to control the software using Visual Basic or VBA. Other off-the-shelf options for OLE control include National Instruments' MATLAB and LabVIEW®. However, none of the aforementioned are OPC (OLE for Process Control) compatible.

There are other out-of-the-box solutions that do not require the writing of application source code. One of these is IRControl from Automation Technology, GmbH. IRControl simplifies automated

processing of complex tasks with its built in Automation Interface based on Microsoft® COM/DCOM. All essential measurement, analysis, and control functions for FLIR IR cameras are directly programmable using macro commands. This allows the execution of control scripts automatically based on digital input events. In addition, IRControl accepts remote control commands sent over an RS-232 link. Therefore, remote control of IRControl by other computers or PLCs is greatly simplified. The software also includes a comprehensive report generator.

Summary

A variety of control and data acquisition options are available for IR cameras (see Figure 7). They are similar to those used with visible light cameras that are employed in machine vision and automation systems. IR cameras provide the added advantage of accurate non-contact temperature measurements within a single instrument.

Combining Machine Vision and Temperature Measurement

Background

Traditionally, visible light cameras have been a mainstay in machine vision systems used for automated inspection and process control. Many of these systems also require temperature measurements to assure product quality. In numerous cases, an IR camera can supply both an image of the product and critical temperature data. If the application will not benefit from thermographic images and non-contact temperature measurements, then a visible light camera is certainly less expensive. If the opposite is true, then an IR camera should be considered by the system designer.

As the sophistication of IR cameras continues to increase, along with associated hardware and software, their use in automated systems is growing rapidly. Because of their combined imaging and temperature measurement capabilities, they can be very cost effective. The main impediment to their wider usage is system designers' lack of familiarity with IR camera features and the related standards, systems, and software that support them. This chapter supplies a good deal of that information.

Machine Vision Applications

As in the case of visible light cameras, thermographic cameras and their associated software can recognize the size, shape, and relative location of target objects (i.e., they can do pattern

matching). Moreover, the electronics in newer IR cameras provide fast signal processing that allows high video frames rates (60Hz or higher) to capture relatively fast-moving parts on a production line. Their A/D converters combine short integration times with 14- to 16-bit resolution, which is critical for properly characterizing moving targets or targets whose temperatures change rapidly.

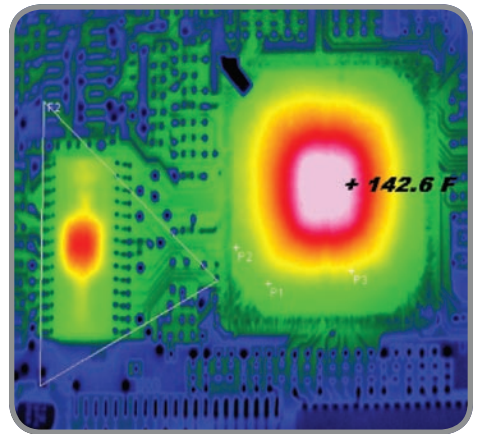

Figure 1. Results of automated inspection of ICs on a circuit board

One example of the latter is automated inspection of operating ICs on a circuit board (Figure 1). In some cases, this involves overload testing in which an IC is subjected to a current pulse so its heat loading can be characterized. In one such case the IC is forward and reverse biased with current levels outside of design limits using a pulse that lasts 800ms. The IR camera captures images during and after the current pulse to characterize temperature rise and fall. With a 60Hz frame rate, a new frame can be captured about every 17ms. In such a system nearly 50 frames can be captured during the 800ms pulse, and many more

Chapter 4

are typically captured afterward to reveal heat dissipation characteristics.

In other applications of this sort, a good image can be stored and compared to the inspection image by using pixel-by-pixel subtraction. Ideally, the resulting image would be entirely black, indicating no difference and a good part. Areas with excessive temperature differences indicate a bad part, making it very easy to discern unwanted differences.

There are many other applications where the combination of non-contact temperature measurements and imaging at high frame rates is extremely valuable. Some automated systems where IR cameras are already being used include:

- Automotive part production and assembly lines
- Steel mill operations, such as slag monitoring and ladle inspection
- Casting, soldering, and welding of metals and plastics
- Food processing lines
- Product packaging
- Non-destructive testing, like sub-surface detection of voids in molded parts
- Electric utility equipment monitoring
- R&D, prototyping, and production in the electronics industry

An interesting automotive example is monitoring the temperature distribution of a pressure casting mold for a safety-critical part (Figure 2). Prior to installation of the IR machine vision system, the manufacturer was doing 100% inspection using an X-ray system to reveal subsurface imperfections. It was not practical to do this as an inline procedure,

so the X-rays were taken a few hours after part production. If the X-rays showed a significant problem in parts coming from a particular mold, this information was relayed to the production area so that mold temperatures could be adjusted. This was a lengthy and costly process that often resulted in high scrap rates. With the IR camera system, the mold operator can immediately check and adjust the temperature distribution of the mold.

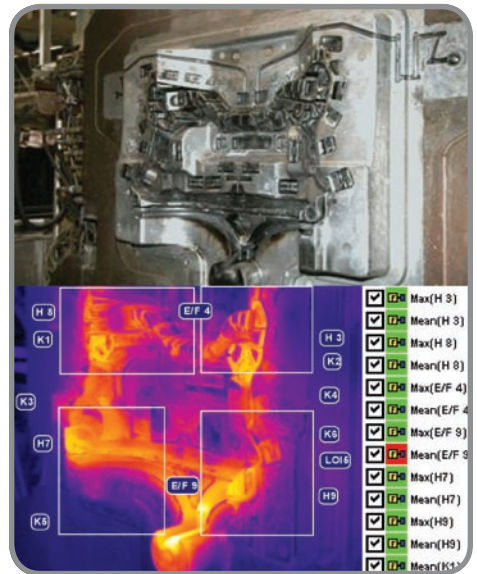

Figure 2. Pressure casting mold and its temperature distribution – an IR camera image is used by the operator to adjust the mold temperatures as required to produce good parts.

Enabling Technology

Data communications are the backbone of modern industrial SCADA, PLC, HMI's, and Machine Vision systems. Ethernet has become the de facto standard for such systems. Considering this, the features of

Combining Machine Vision and Temperature Measurement

IR cameras that make for practical use in machine vision applications are Gigabit Ethernet (GigE) connectivity, GigE Vision™ compliance, a GenICam™ interface, and a wide range of third party software that supports these cameras. There are other hardware features that are also important.

Generally, ultra-high detector resolutions are not needed in the targeted applications, so a typical focal plane array (FPA) would be 320x240 pixels. Nevertheless, outputting a 16-bit image stream of these 76,800 pixels at a 60Hz frame rate amounts to about 74Mb/sec. While this is much slower than a 100baseT Ethernet system is capable of, multiple cameras may be connected and there may be a lot of other traffic on the network between image transmissions.

To speed up image transfers, data analysis and decision-making must take place outside the camera and is one of the reasons why there is a good market for third-party thermographic software. The other reason is that most machine vision systems are custom designed for specific production processes. Of course, IR camera manufacturers supply various types of software to support their products and facilitate application in these systems.

The goal of the GigE Vision technical standard is to provide a version of GigE that meets the requirements of the machine vision industry. One of the industry objectives is the ability to mix and match components from various manufacturers that meet the standard. Another is relatively inexpensive accessories, such as cabling, switches, and network interface cards (NICs) as well

as the ability to use relatively long cable runs where required.

The GigE Vision standard, which is based on UDP/IP, has four main elements:

- A mechanism that allows the application to detect and enumerate devices and defines how the devices obtain a valid IP address.
- GigE Vision Control Protocol (GVCP) that allows the configuration of detected devices and guarantees transmission reliability.
- GigE Vision Streaming Protocol (GVSP) that allows applications to receive information from devices.
- Bootstrap registers that describe the device itself (current IP address, serial number, manufacturer, etc.).

With GigE capabilities and appropriate software, an IR machine vision system does not require a separate frame grabber, which was typically the case with visible light cameras in the past. In effect, the GigE port on the PC is the frame grabber. Older visible light cameras that have only analog video outputs (NTSC and PAL) are limited to much lower frame rates and video monitor observations. By using GigE, an IR vision system not only has higher frame rates, but can be monitored remotely over much greater distances compared to local processing and transmitting data over USB, Firewire, CameraLink, etc. In addition, Ethernet components are inexpensive compared to frame-grabber cards and related hardware.

A GigE Vision camera typically uses an NIC, and multiple cameras can be connected on the network. However, the drivers supplied by NIC manufacturers

use the Windows or Linux IP stack, which may lead to unpredictable behavior, such as data transmission delays. By using more efficient dedicated drivers compatible with the GigE Vision standard, the IP stack can be bypassed and data streamed directly to memory at the kernel level of the PC system. In other words, Direct Memory Access (DMA) transfers are negotiated, which also eliminates most CPU intervention. Thus a near-real-time IR vision system is created in which almost all of the CPU time is dedicated to processing images.

To make sure a camera is GigE Vision compliant, look for the official stamp (shown in Figure 3) that can only be applied if the camera conforms to the standard.



Figure 3. Official trademark for GigE compliant products

GenICam compliance should also be considered for an IR camera. GenICam compliance makes it easier for developers to integrate cameras into their IR vision system. The goal of the GenICam standard is to provide a generic programming interface for all kinds of cameras. No matter what interface technology (GigE Vision, Camera Link, 1394, etc.) is used, or what camera features are being implemented, the application programming interface (API) should be the same. The GenICam standard consists of multiple modules and the main tasks each performs are:

- GenApi: configuring the camera
- Standard Feature Names: recommended names and types for common features
- GenTL: transport layer interface, grabbing images

The GenApi and Standard Feature Names modules are currently part of the standard module only. GenTL should be finished soon.

Common tasks associated with IR cameras in machine vision systems include configuration settings, command and control, processing the image, and appending temperature measurement results to the image data stream. In addition, the camera's digital I/O can be used to control other hardware, and there are triggering and synchronization functions associated with real-time data acquisition. GigE Vision makes hardware independence possible, while GenICam creates software independence. For example, in a system with IR cameras compliant in both and connected to a GigE network, virtually any application program can command a camera to send a 60Hz stream of images that can be easily captured without dropping frames and losing important data. This information can be processed for alarm functions, trend analysis and statistical process control.

Third Party Software Expands Applications

By adhering to the standards described above, IR camera manufacturers are making it easier for developers to integrate their cameras into vision systems with a broad array of functions

Combining Machine Vision and Temperature Measurement

Turnkey Solutions for:

- Process Control
- Process Monitoring
- Non-Destructive Testing
- Custom Systems

- Critical Vessel Monitoring
- Package Sealing
- Waste Bunker Monitoring
- Petrochemical Perimeter Security
- Plant Monitoring
- Solar Panel Inspection
- Composite Material Testing



movimed
Custom Imaging Solutions

(949) 699-6600 www.movimed.com

Figure 4. IR cameras can be used in a broad array of applications

(Figure 4). Camera manufacturers also supply a variety of software products to ease integration tasks. For example, the FLIR A325 comes with three packages that run on a PC controller:

- IP Configuration utility – finds cameras on the network and configures them
- IR Monitor – displays images and temperature data on up to nine cameras simultaneously
- AXXX Control and Image interface – low-level descriptions of how to communicate with the camera, including image formats and C-code examples

In addition, optional software developer toolkits are available (FLIR SDK, LabVIEW SDK, Active GigE SDK from A&B Software, etc.) for those creating source code for custom applications within programming environments such as Visual Basic, C++, Delphi, etc. However, the strength of a camera like the A325 is its ability to interface with third party software that eliminates or minimizes the need to write source code. For example, National Instrument's Vision Builder for Automated Inspection is a configurable package for building, benchmarking, and deploying machine vision applications (Figure 5). It does not require the user to write program code. A built-in deployment interface facilitates system installation

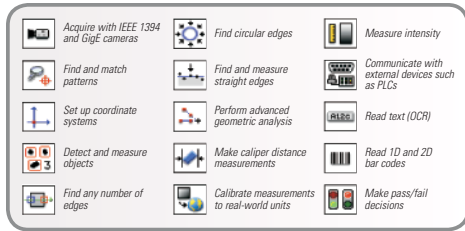

Figure 3. Examples of the many functions available in Vision Builder for automated inspection

and includes the ability to define complex pass/fail decisions, control digital I/O, and communicate with serial or Ethernet devices, such as PLCs, PCs, and HMIs. Similar features are available in Common Vision Blox, a Stemmer Imaging product that contains hardware- and language-independent tools and libraries for imaging professionals.

By using third party software to get much of the analytics, command, and control functions out of the camera and onto a PC, application possibilities are greatly expanded. One possibility is creating a mixed camera system. For instance, IR cameras could be used to supply thermal images and temperature data, while visible light cameras could provide “white light” color recognition.

The food processing industry is one in which higher level analytics are used with IR cameras for automated machine vision applications. A broad area of applications where IR vision systems excel is in 100% inspection of cooked food items coming out of a continuous conveyor oven. A primary concern is making sure the items have been thoroughly cooked, which can be determined by having the camera measure their temperature, which is illustrated in Figure 6 for

hamburger patties. This can be done by defining measurement spots or areas corresponding to the locations of burgers as they exit the oven. If the temperature of a burger is too low, the machine vision program logic not only provides an alarm, but also displays an image to the oven operator to show the specific burger that should be removed from the line. As in other applications, minimum, maximum, and average temperatures can be collected for specific burgers or the FOV as a whole and used for trending and SPC purposes.

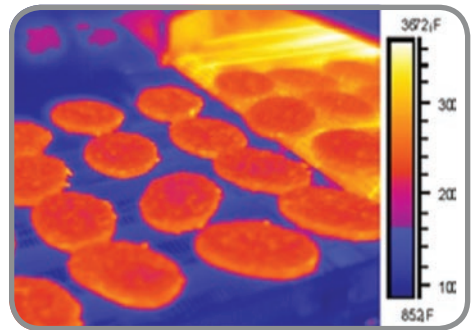

Figure 6. IR machine vision image for checking hamburger doneness by measuring temperature

In another example involving chicken tenders, temperature is again used to check for proper cooking. The pieces come out of the oven and drop onto another conveyor in more or less random locations (Figure 7). The operator can use the thermographic image to locate undercooked items within the randomly spaced parts and then remove them from the conveyor.

In the production of frozen entrées, IR machine vision can use pattern recognition software to check for proper filling of food tray compartments.

Combining Machine Vision and Temperature Measurement



Figure 7. An IR temperature measurement and thermographic image are used to locate undercooked chicken tenders and stop the line so bad parts can be removed.

Similarly, it can be used for 100% inspection of the heat-sealed cellophane cover over the finished entrée. An added function could be laser marking of a bad item so it can be removed at the inspection station.

Summary

IR machine vision and temperature measurements can be applied to an

infinite number of automated processes. In many cases, they provide images and information that are not available with visible light cameras, and they also complement white light images where the latter are required. IR cameras like the FLIR A325 provide a stream of digitized IR images at fast frame rates for relatively high-speed processes, which can be transmitted over GigE networks to remote locations. Compliance with GigE Vision and GenICam standards means that such cameras can be integrated with a wide variety of similarly compliant equipment and supported by a broad range of third party software. Trigger and synchronization capabilities allow them to control, or be controlled by, a host of other types of equipment. The availability of wireless and fiberoptic line adapters allow these cameras to be used almost anywhere, including over long distances.

Real-Time Control Issues

Background

Real-time control is an important issue in most IR machine vision systems used for automated temperature monitoring and inspection. Having said that, it should be noted that real time tends to be a relative term, the measure of which varies with the application and user requirements. In some applications, users would consider a response time of 100 milliseconds to meet their definition of real-time. On the other hand, many electronic events are extremely fast or short-lived, and a one-microsecond response might be needed. As mentioned in earlier chapters, process temperatures tend to change relatively slowly, so an IR machine vision system that can update images and temperatures every 10-100ms, or even less frequently, may be adequate.

Hardware and Software Platform Considerations

In most cases, a PC with a Microsoft Windows operating system (OS) isn't well suited for controlling fast, real-time applications. Windows is referred to as a non-deterministic OS because it typically cannot provide predictable response times in critical measurement and control situations. Therefore, the solution is to link the PC to a system that can operate autonomously and provide rapid, predictable responses to external stimuli.

Deterministic applications (those intended to be event driven) are controlled better with systems based on an embedded microprocessor and/or digital signal processor (DSP) that has a different type of OS – or perhaps a special version of Windows other than the ones typically found on a home or

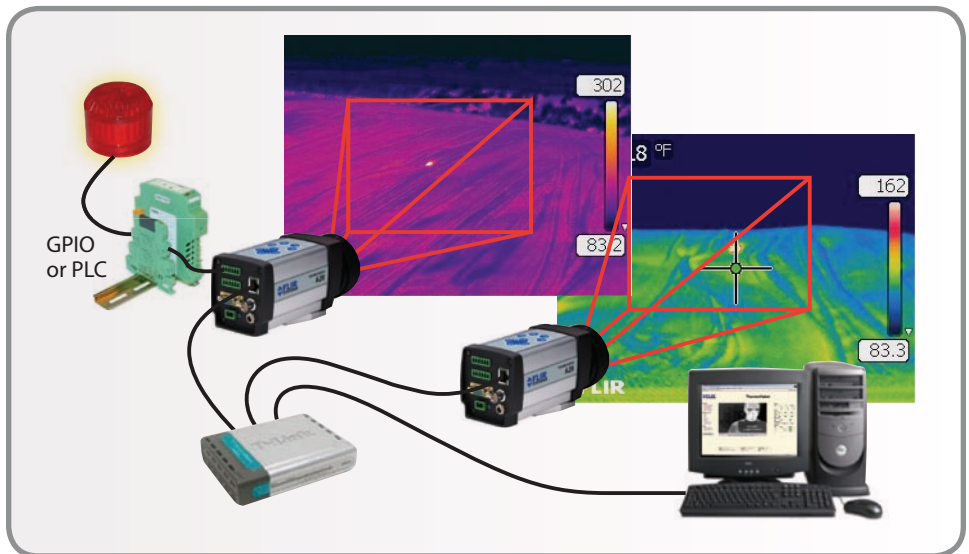

Figure 1. PLCs are a good choice for creating deterministic (event-driven) systems, supported by a PC that is used for data trending.

office PC. Often, a system based on a PLC with 115VAC control I/O is much more appropriate for real-time applications (Figure 1). PLC processors are designed to operate with deterministic control loops, and the 115VAC control signals are inherently immune to noisy industrial environments.

If the required response time is long enough, and there are other reasons to use one of the familiar Windows operating systems, keep in mind that special steps are needed to improve its data polling methodology. In a polled system, the PC checks many devices to see if they're ready to send or receive data. In the context of data acquisition from an Ethernet-based IR camera, this typically involves reading values from a data stream. In a Windows-based PC, the time between polled readings is scheduled by Windows, so it's non-deterministic. In other words, the time at which Windows will initiate an operation cannot be known precisely. Its operation depends on any number of system factors, such as computer speed, the OS, programming languages, and application code optimization.

Polling can be appropriate with slower, less time-sensitive operations. In contrast, event-driven programming schemes are less dependent on OS timing and tend to reduce latency problems. They can be used to create more deterministic systems that collect discrete data values that are closely related to the physical phenomena being represented.

Creating such a system within a Windows OS environment generally requires writing program code using Visual C/C++ , Visual Basic, etc. Using

these tools, a programmer can take advantage of Windows events and messaging functionality to create a more deterministic application that runs relatively fast and provides tight control. Rather than constantly polling to determine if data is ready for collection, such programs can use the PC's CPU for additional tasks, such as database or network access, until interrupted by the automation system hardware. As discussed in Chapter 4, there are software developer kits that take some of the work out of these tasks, and third party software packages can eliminate or minimize the need to write program code. An example is illustrated in Figure 2.

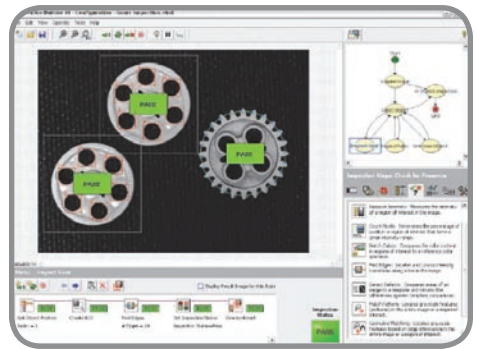
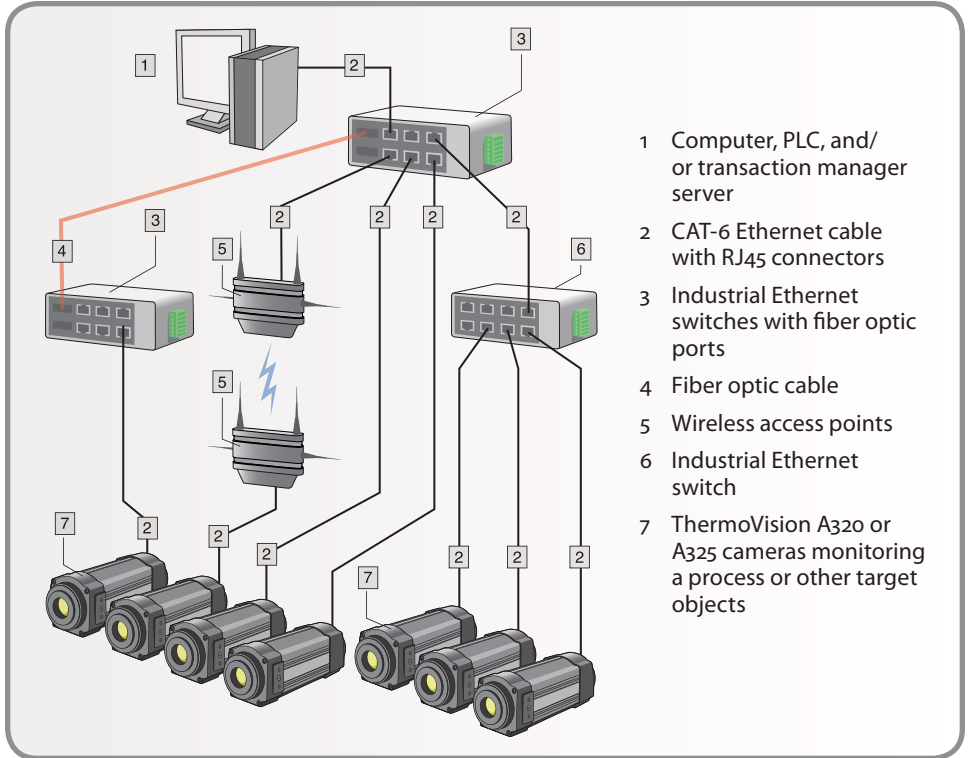

Figure 2. Third party software provides powerful control and analytic tools for IR machine vision systems without writing program code.

Data Communication Latencies

Hardware and data communications have significant effects on system response time. The Ethernet interfaces on many IR cameras allow communication distances of 4000 feet or more. Wireless and fiberoptic adapters and hubs can extend the scope of the network even more. Networked systems require the



- 1 Computer, PLC, and/or transaction manager server
- 2 CAT-6 Ethernet cable with RJ45 connectors
- 3 Industrial Ethernet switches with fiber optic ports
- 4 Fiber optic cable
- 5 Wireless access points
- 6 Industrial Ethernet switch
- 7 ThermoVision A320 or A325 cameras monitoring a process or other target objects

Figure 3. Generalized IR machine vision system and its communications network

installation of one or more NICs in the PC and configuring its OS for network support. These requirements are easily and economically met with Ethernet, TCP/IP, and Windows, as described in Chapter 3.

A functional drawback of Ethernet-based systems concerns real-time control. Like Windows, Ethernet is a non-deterministic system that in many applications precludes fast, real-time process control. This can become even more of an issue when the World Wide Web is involved. Again, there are work-arounds to minimize inherent weaknesses. As

mentioned in Chapter 4, drivers supplied by NIC manufacturers use the Windows or Linux IP stack, which may result in data transmission delays. By using dedicated drivers compatible with the GigE Vision standard, data can be streamed directly to memory using a DMA transfer.

Since older communication protocols (RS-232, 422, 485, etc.) are even slower, Ethernet is still the protocol of choice in most IR machine vision systems. The digitized streaming video from FLIR's A325 camera allows near-real-time data acquisition of thermal images and temperature data – provided the

PC has the appropriate NIC driver and application program. Network adapters for fiberoptic and wireless connectivity can extend Ethernet's scope (Figure 3). Other hardware timing issues can be minimized by using direct-wired digital I/O and triggering between individual cameras, PLCs, etc. Analog video (NTSC and PAL) for conventional image monitoring is probably most applicable to qualitative applications where timing is not critical.

IR Camera Hardware and Firmware Issues

Thermal Time Constants for Cooled and Uncooled IR Cameras. In general, time constant refers to the time it takes for a sensing element to respond to within 63.2% of a step change in the state of a target that is being sensed (Figure 4). In IR sensing and thermography, the thermal time constant of an IR camera's detector is a limiting factor in instrument performance as it relates to response time.

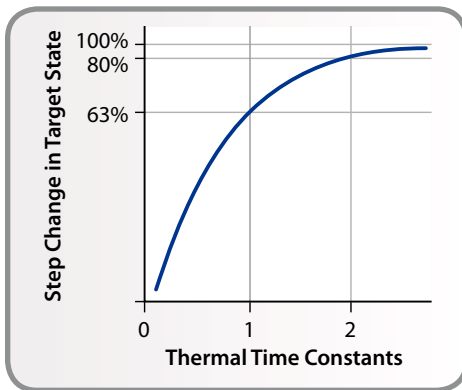

Figure 4. Thermal time constant concept showing an integral number of time constants on the X-axis.

Older IR cameras have response times similar to the human eye, so they are unsuitable for capturing thermal images of fast moving objects or those with rapidly changing temperatures. Newer IR cameras have detectors and digital electronics with response times in the sub-millisecond region. Cooled quantum detectors are very sensitive and very fast (sub-microsecond response times), but their bulkiness and cost tends to rule them out of many automation applications. In addition, quantum detectors have response curves with detectivity that varies strongly with IR wavelength. FLIR has made recent improvements to its uncooled broadband microbolometer detectors and associated A/D converters so they can continuously output images with embedded temperature data at a 60Hz rate. This is satisfactory for most temperature monitoring and IR machine vision applications.

Temperature Measurement Range.

The overall temperature range of an IR camera is primarily a function of its detector and calibration. Camera electronics, which include calibration functions, can handle wide variations in absolute detector sensitivities. For example, the FLIR A325's overall measurement range is divided into user-selectable temperature scales that have a measurement accuracy of $\pm 2^{\circ}\text{C}$ ($\pm 3.6^{\circ}\text{F}$) or $\pm 2\%$ of reading:

- -20°C to $+120^{\circ}\text{C}$ (-4°F to $+248^{\circ}\text{F}$)
- 0°C to $+350^{\circ}\text{C}$ (32°F to $+662^{\circ}\text{F}$)
- Optionally, 250°C to $+1200^{\circ}\text{C}$ (482°F to 2192°F)

This is a valuable feature when a scene has a temperature range narrower than

a camera's overall range. Selecting a narrower scale allows better resolution of the images and higher accuracy in the measured temperatures. Therefore, the images will better illustrate smaller temperature differences. On the other hand, a broader scale and/or higher maximum temperature range may be needed to prevent saturation of the portion of the image at the highest temperature.

It's important to understand how the camera's calibration and temperature measurement processes affect its response time. IR cameras measure irradiance, not temperature, but the two are related. When an IR camera is thermographically calibrated, it can measure temperatures based on standard blackbody radiances at specific temperatures. As will be discussed later, the emissivity of the target object being measured is vital to achieving accurate temperature readings. (Emissivity or emittance is the radiative properties of an object relative to a perfect blackbody.)

When an IR camera is calibrated at the factory, calibration factors are stored internally as a table of values based on the camera's A/D counts from the temperature/radiance measurements of a standard blackbody. When the system makes a measurement in an application, it takes the digital value of the signal at a given moment, goes into the appropriate calibration table, and calculates temperature. Before the final result is presented, due consideration is given to other factors, like emissivity of the target objects, atmospheric attenuation, reflected ambient temperature, and the camera's ambient temperature drift.

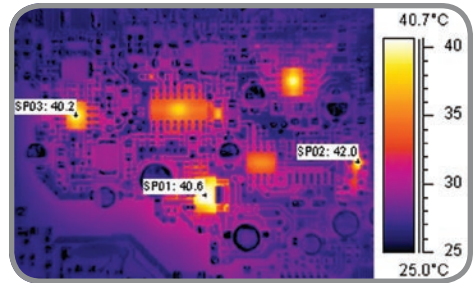

Figure 5. Creating a temperature scale narrower than the camera's full range improves image resolution and may improve defect detection.

As an adjunct to major temperature scale selections, most IR cameras allow a user to set up a color scale or gray scale for a temperature range that's even narrower (Figure 5). This should be done where practical, not only because of improved image resolution, but also because of response time considerations. A narrower temperature range can reduce the A/D converter's processing load and overall response time of the system.

Another complexity is the fact that each individual pixel in the camera's focal plane array has a slightly different gain and zero offset. To create a useful thermographic image, the different gains and offsets must be corrected to a normalized value. This multi-step calibration process is performed by the camera firmware (Figure 6). The non-uniformity correction (NUC) factors are also stored in a table.

IR cameras also have different measurement modes: spotmeter and area measurements in the case of the FLIR A320 Series. The spotmeter finds the temperature at a particular point whereas the area function isolates a selected area of an object or scene. In the latter case,

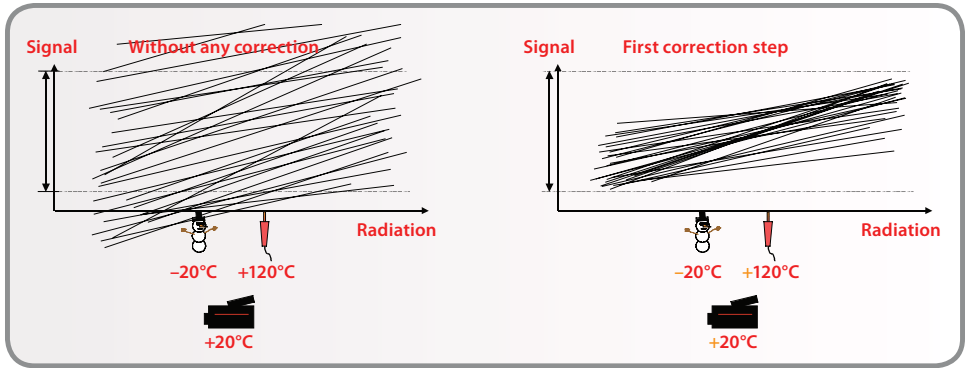

Figure 6a. First step in detector non-uniformity correction (NUC) performed by IR camera firmware

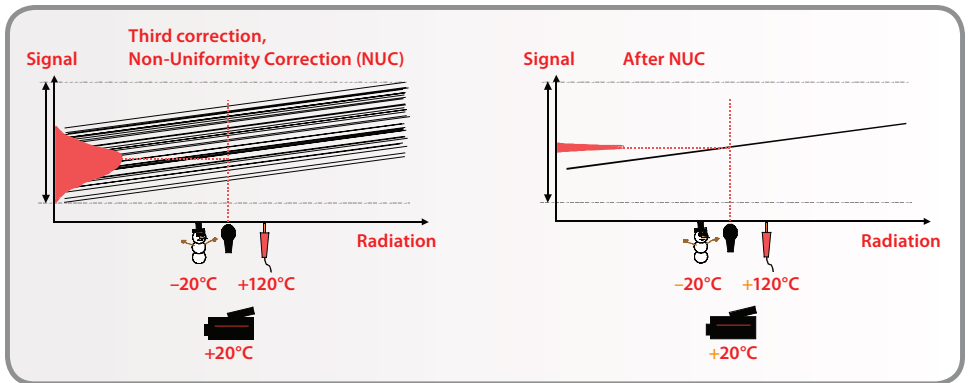

Figure 6b. Final steps in IR camera's NUC process

camera firmware finds the minimum and maximum temperatures and calculates the average temperature inside the area selected. Clearly, more processing time is required for area measurements, particularly if multiple areas are selected. This also means that more data is being transmitted over a machine vision system's communications network, along with more latency.

Emissivity Calibration. Earlier, it was pointed out that accurate temperature measurements on a specific object

require the emissivity value for that object. In effect, this adjusts the factory calibration that is based on a perfect blackbody having an emissivity value of 1.0. This adjustment consumes processor time. To avoid this, the FLIR A325 uses a global emissivity value (input by the user) for the camera's entire FOV. Normally, this isn't a problem for machine vision applications and it avoids the time required to apply non-global emissivity values on the fly. Instead, the application program is set up to make decisions

based on the temperature value of a target area compared to a standard value or compared to the target's surroundings. While this may not be accurate in an absolute sense, it is the relative difference that is most important.

If the system developer wants accurate temperature measurements on different objects with different emissivities (e.g., for PC board inspections), then he/she must create an emissivity map for the camera's FOV. This cannot be done with the data coming out of a camera using a global emissivity value. To create an emissivity map, the developer will need to write some program code, typically by using the FLIR Software Developers Kit. The routine that's developed sets up the system to read the FLIR proprietary stream of data coming out of the A/D converter and applies emissivity values to it. This creates an emissivity map that covers selected areas or spots within the FOV.

Important Thermographic Principles

As alluded to above, there must be a temperature difference between a target object and its surroundings in order to create a useful thermographic image. In most situations, the user also needs a measurement of this relative temperature difference for decision making, either automatically or by a machine operator. However, there are a few ambient conditions that may obscure the temperature difference.

In addition to emitting radiation, an object reacts to incident radiation from its surroundings by absorbing and reflecting a portion of it or by allowing some of it to pass through (as through a

lens). Therefore, the maximum radiation that impinges on an IR camera lens aimed at an object comes from three sources: (1) the object's inherent temperature without influence from its surroundings, (2) radiation from its surroundings that was reflected onto the object's surface, and (3) radiation that passed through the object from behind. This is known as the Total Radiation Law (see below). However, all these radiation components become attenuated as they pass through the atmosphere on their way to the camera lens. Since the atmosphere absorbs part of the radiation, it also radiates some itself.

Total Radiation Law

$$1 = \alpha + \rho + \tau.$$

The coefficients α , ρ , and τ describe an object's incident energy absorption (α), reflection (ρ), and transmission (τ).

Figure 7. Total Radiation Law

The role of emissivity in distinguishing an object's temperature from its surroundings was discussed above. As alluded to earlier, it's wise to take precautions that prevent reflected energy from impinging on the target. Corrections for atmospheric attenuation are normally built into the camera firmware. Still, other gases and hot steam between the target and the camera lens can make measurements impossible, or at least inaccurate. Similarly, an object that is transparent to IR wavelengths may result in the camera measuring the background behind it or some combination of the object and the background.

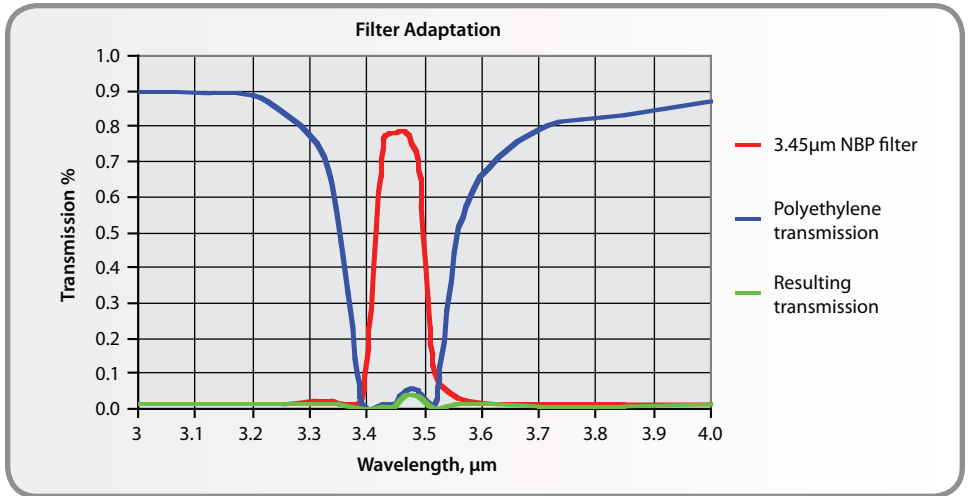

Figure 8. Application of a narrow bandpass (NBP) filter to achieve nearly complete absorption and high emittance (green curve) from polyethylene film, allowing its temperature measurement.

In the last two cases, spectral filters that are selective at specific wavelengths can help. Certain filters can make an otherwise opaque gas appear transparent or a transparent object appear opaque over the appropriate IR band (Figure 8).

Summary

IR cameras used in machine vision and other automation systems are analogous to visible light cameras in similar systems. White light cameras have optical issues that must be managed, whereas IR cameras have thermographic issues to resolve. In both cases, achieving real-time

(or near-real-time) response requires thoughtful selection of the controller and careful design of the application program. Third party software can provide out-of-the-box program development tools that eliminate or minimize the need to write program code. Generally, there are no perfect solutions – developing an automated machine vision system, whether based on visible light or IR, usually involves compromises of one sort or another. The camera manufacturer can be a great source of help in developing these systems.

Glossary

absorption (absorption factor). The amount of radiation absorbed by an object relative to the received radiation. A number between 0 and 1.

ambient. Objects and gases that emit radiation towards the object being measured.

atmosphere. The gases between the object being measured and the camera, normally air.

autoadjust. A function making a camera perform an internal image correction.

autopalette. The IR image is shown with an uneven spread of colors, displaying cold objects as well as hot ones at the same time.

blackbody. Totally non-reflective object. All its radiation is due to its own temperature.

blackbody radiator. An IR radiating device with blackbody properties used to calibrate IR cameras.

calculated atmospheric transmission. A transmission value computed from the temperature, the relative humidity of the air, and the distance to the object.

cavity radiator. A bottle shaped radiator with an absorbing inside, viewed through the bottleneck.

color temperature. The temperature for which the color of a blackbody matches a specific color.

conduction. The process that makes heat spread into a material.

continuous adjust. A function that adjusts the image. The function works

all the time, continuously adjusting brightness and contrast according to the image content.

convection. The process that makes hot air or liquid rise.

difference temperature. A value that is the result of a subtraction between two temperature values.

dual isotherm. An isotherm with two color bands instead of one.

emissivity (emissivity factor). The amount of radiation coming from an object compared to that of a blackbody. A number between 0 and 1.

emittance. Amount of energy emitted from an object per unit of time and area (W/m^2).

estimated atmospheric transmission. A transmission value, supplied by a user, replacing a calculated one.

external optics. Extra lenses, filters, heat shields etc. that can be put between the camera and the object being measured.

filter. A material transparent only to some of the infrared wavelengths.

FOV. Field of view: The horizontal angle that can be viewed through an IR lens.

FPA. Focal plane array: A type of IR detector.

graybody. An object that emits a fixed fraction of the amount of energy of a blackbody for each wavelength.

IFOV. Instantaneous Field Of View: A measure of the geometrical resolution of an IR camera.

image correction (internal or external). A way of compensating for sensitivity differences in various parts of live images and also of stabilizing the camera.

infrared. Non-visible radiation, with a wavelength from about 2–13 μm .

IR. Infrared.

isotherm. A function highlighting those parts of an image that fall above, below, or between one or more temperature intervals.

isothermal cavity. A bottle-shaped radiator with a uniform temperature viewed through the bottleneck.

Laser LocatIR. An electrically powered light source on the camera that emits laser radiation in a thin, concentrated beam to point at certain parts of the object in front of the camera.

laser pointer. An electrically powered light source on the camera that emits laser radiation in a thin, concentrated beam to point at certain parts of the object in front of the camera.

level. The center value of the temperature scale, usually expressed as a signal value.

manual adjust. A way to adjust the image by manually changing certain parameters.

NETD. Noise equivalent temperature difference: A measure of the image noise level of an IR camera.

noise. Undesired small disturbance in the infrared image.

object parameters. A set of values describing the circumstances under

which the measurement of an object was made and the object itself (such as emissivity, ambient temperature, distance, etc.)

object signal. A non-calibrated value related to the amount of radiation received by the camera from the object.

palette. The set of colors used to display an IR image.

pixel. A picture element. One single spot in an image.

radiance. Amount of energy emitted from an object per unit of time, area, and angle ($\text{W}/\text{m}^2/\text{sr}$).

radiant power. Amount of energy emitted from an object per unit of time (W).

radiation. The process by which electromagnetic energy is emitted by an object or a gas.

radiator. A piece of IR radiating equipment.

range. The current overall temperature measurement limitation of an IR camera. Cameras can have several ranges, which are expressed as two blackbody temperatures that limit the current calibration.

reference temperature. A temperature which the ordinary measured values can be compared with.

reflection. The amount of radiation reflected by an object relative to the received radiation. A number between 0 and 1.

relative humidity. Percentage of water in the air relative to what is physically possible. Air temperature dependent.

saturation color. The areas that contain temperatures outside the present level/span settings are colored with the saturation colors. The saturation colors contain an “overflow” color and an “underflow” color. There is also a third red saturation color that marks everything saturated by the detector indicating that the range should probably be changed.

span. The interval of the temperature scale, usually expressed as a signal value.

spectral (radiant) emittance. Amount of energy emitted from an object per unit of time, area, and wavelength ($W/m^2/\mu m$).

temperature range. The current overall temperature measurement limitation of an IR camera. Cameras can have several ranges. They are expressed as two

blackbody temperatures that limit the current calibration.

temperature scale. The way in which an IR image currently is displayed. Expressed as two temperature values limiting the colors.

thermogram. Infrared image.

transmission (or transmittance) factor. Gases and materials can be more or less transparent. Transmission is the amount of IR radiation passing through them. A number between 0 and 1.

transparent isotherm. An isotherm showing a linear spread of color, instead of covering the highlighted parts of the image.

visual. Refers to the video mode of an IR camera as opposed to the normal, thermographic mode. When a camera is in video mode it captures ordinary video images, while thermographic images are captured when the camera is in IR mode.

Thermographic Measurement Techniques

Introduction

An infrared camera measures and images the emitted infrared radiation from an object. The fact that radiation is a function of object surface temperature makes it possible for the camera to calculate and display this temperature.

However, the radiation measured by the camera does not only depend on the temperature of the object but is also a function of the emissivity. Radiation also originates from the surroundings and is reflected in the object. The radiation from the object and the reflected radiation will also be influenced by the absorption of the atmosphere.

To measure temperature accurately, it is therefore necessary to compensate for the effects of a number of different radiation sources. This is done on-line automatically by the camera. The following object parameters must, however, be supplied for the camera:

- The reflected temperature
- The distance between the object and the camera
- The relative humidity
- The emissivity of the object

The most important object parameter to set correctly is the emissivity which, in short, is a measure of how much radiation is emitted from the object, compared to that from a perfect blackbody.

Normally, object materials and surface treatments exhibit emissivity ranging from approximately 0.1 to 0.95. A highly

polished (mirror) surface falls below 0.1, while an oxidized or painted surface has much higher emissivity. Oil-based paint, regardless of color in the visible spectrum, has an emissivity of over 0.9 in the infrared. Human skin exhibits an emissivity close to 1.

Non-oxidized metals represent an extreme case of almost perfect opacity and high spectral reflexivity, which does not vary greatly with wavelength. Consequently, the emissivity of metals is low – only increasing with temperature. For non-metals, emissivity tends to be high and decreases with temperature.

Finding the Emissivity of an Object Using a Thermocouple

Select a reference point and measure its temperature using a thermocouple. Alter the emissivity until the temperature measured by the camera agrees with the thermocouple reading. This is the emissivity value of the reference object. However, the temperature of the reference object must not be too close to the ambient temperature for this to work.

Finding the Emissivity of an Object Using Reference Emissivity

A tape or paint of a known emissivity should be put onto the object. Measure the temperature of the tape/paint using the camera, setting emissivity to the correct value. Note the temperature. Alter the emissivity until the area with the unknown emissivity adjacent to the tape/paint has the same temperature reading. The emissivity value can now be read. The temperature of the reference object must not be too close to the ambient temperature for this to work either.

Reflected Temperature Parameter

This parameter is used to compensate for the radiation reflected in the object and the radiation emitted from the atmosphere between the camera and the object.

If the emissivity is low, the distance very long, and the object temperature relatively close to that of the reflected object, it is important to set and compensate for the reflected temperature correctly.

Distance Parameter

This is the distance between the object and the front lens of the camera.

This parameter is used to compensate for the fact that radiation is being absorbed between the object and the camera and the fact that transmittance drops with distance.

Relative Humidity Parameter

The camera can also compensate for the fact that transmittance is somewhat dependent on the relative humidity of the atmosphere. To do this, set the relative humidity to the correct value. For short distances and normal humidity, the relative humidity can normally be left at a default value of 50%.

Other Parameters

In addition, some cameras and analysis programs from FLIR Systems allow you to compensate for the following parameters:

- Atmospheric temperature – the temperature of the atmosphere between the camera and the target
- External optics temperature – the temperature of any external lenses or windows used in front of the camera
- External optics transmission – the transmission of any external lenses or windows used in front of the camera

History and Theory of Infrared Technology

Less than 200 years ago the existence of the infrared portion of the electromagnetic spectrum wasn't even suspected. The original significance of the infrared spectrum, or simply "the infrared" as it is often called, as a form of heat radiation is perhaps less obvious today than it was at the time of its discovery by Sir William Herschel in 1800 (Figure 1).



Figure 1. Sir William Herschel (1738–1822)

The discovery was made accidentally during the search for a new optical material. Sir William Herschel – Royal Astronomer to King George III of England, and already famous for his discovery of the planet Uranus – was searching for an optical filter material to reduce the brightness of the sun's image in telescopes during solar observations. While testing different samples of colored glass which gave similar reductions in brightness, he was intrigued to find that some of the samples passed very little of the sun's heat, while others passed so much heat that he risked eye damage after only a few seconds' observation.

Herschel was soon convinced of the necessity of setting up a systematic

experiment with the objective of finding a single material that would give the desired reduction in brightness as well as the maximum reduction in heat. He began the experiment by actually repeating Newton's prism experiment, but looking for the heating effect rather than the visual distribution of intensity in the spectrum. He first blackened the bulb of a sensitive mercury-in-glass thermometer with ink, and with this as his radiation detector he proceeded to test the heating effect of the various colors of the spectrum formed on the top of a table by passing sunlight through a glass prism. Other thermometers, placed outside the sun's rays, served as controls.

As the blackened thermometer was moved slowly along the colors of the spectrum, the temperature readings showed a steady increase from the violet end to the red end. This was not entirely unexpected, since the Italian researcher, Landriani (Figure 2), in a similar experiment in 1777, had observed much the same effect. It was Herschel, however, who was the first to recognize that there must be a point where the heating effect reaches a maximum, and that measurements confined to the visible portion of the spectrum failed to locate this point.



Figure 2. Marsilio Landriani (1746–1815)

Moving the thermometer into the dark region beyond the red end of the spectrum, Herschel confirmed that the heating continued to increase. The maximum point, when he found it, lay well beyond the red end – in what is known today as the infrared wavelengths.

When Herschel revealed his discovery, he referred to this new portion of the electromagnetic spectrum as the thermometrical spectrum. The radiation itself he sometimes referred to as dark heat, or simply the invisible rays. Ironically, and contrary to popular opinion, it wasn't Herschel who originated the term infrared. The word only began to appear in print around 75 years later and it is still unclear who should receive credit as the originator.

Herschel's use of glass in the prism of his original experiment led to some early controversies with his contemporaries about the actual existence of the infrared wavelengths. Different investigators, in attempting to confirm his work, used various types of glass indiscriminately, having different transparencies in the infrared. Through his later experiments, Herschel was aware of the limited transparency of glass to the newly-discovered thermal radiation, and he was forced to conclude that optics for the infrared would probably be doomed to the use of reflective elements exclusively (plane and curved mirrors). Fortunately, this proved to be true only until 1830, when the Italian investigator Melloni (Figure 3) made his great discovery that naturally occurring rock salt (NaCl) – which was available in large enough natural crystals to be made into lenses and prisms – is remarkably transparent

to the infrared. The result was that rock salt became the principal infrared optical material and remained so for the next hundred years until the art of synthetic crystal growing was mastered in the 1930s.



Figure 3. Macedonio Melloni (1798–1854)

Thermometers, as radiation detectors, remained unchallenged until 1829, the year Nobili invented the thermocouple. (Herschel's own thermometer could be read to 0.2°C (0.036°F), and later models were able to be read to 0.05°C (0.09°F .) Then a breakthrough occurred; Melloni connected a number of thermocouples in series to form the first thermopile. The new device was at least 40 times as sensitive as the best thermometer of the day for detecting heat radiation – capable of detecting the heat from a person standing three meters away.

The first so-called heat-picture became possible in 1840, the result of work by Sir John Herschel, son of the discoverer of infrared and a famous astronomer in his own right. Based upon the differential evaporation of a thin film of oil when exposed to a heat pattern focused upon it, the thermal image could be seen by reflected light where the interference effects of the oil film made the image

visible to the eye. Sir John also managed to obtain a primitive record of the thermal image on paper, which he called a thermograph.

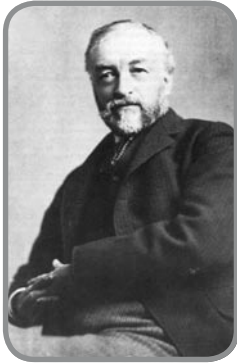

Figure 4. Samuel P. Langley (1834–1906)

The improvement of infrared-detector sensitivity progressed slowly. Another major breakthrough, made by Langley (Figure 4) in 1880, was the invention of the bolometer. This consisted of a thin blackened strip of platinum connected in one arm of a Wheatstone bridge circuit upon which the infrared radiation was focused and to which a sensitive galvanometer responded. This instrument is said to have been able to detect the heat from a cow at a distance of 400 meters.

An English scientist, Sir James Dewar, first introduced the use of liquefied gases as cooling agents (such as liquid nitrogen with a temperature of -196°C (-320.8°F)) in low temperature research. In 1892 he invented a unique vacuum insulating container in which it is possible to store liquefied gases for entire days. The common thermos bottle, used for storing hot and cold drinks, is based upon his invention.

Between the years 1900 and 1920, the inventors of the world “discovered” infrared. Many patents were issued for devices to detect personnel, artillery, aircraft, ships – and even icebergs. The first operating systems, in the modern sense, began to be developed during World War I, when both sides had research programs devoted to the military exploitation of the infrared. These programs included experimental systems for enemy intrusion/detection, remote temperature sensing, secure communications, and “flying torpedo” guidance. An infrared search system tested during this period was able to detect an approaching airplane at a distance of 1.5 km (0.94 miles) or a person more than 300 meters (984 ft.) away.

The most sensitive systems up to this time were all based upon variations of the bolometer idea, but the period between the two world wars saw the development of two revolutionary new infrared detectors: the image converter and the photon detector. At first, the image converter received the greatest attention by the military, because it enabled an observer for the first time in history to literally see in the dark. However, the sensitivity of the image converter was limited to the near infrared wavelengths, and the most interesting military targets (enemy soldiers) had to be illuminated by infrared search beams. Since this involved the risk of giving away the observer’s position to a similarly-equipped enemy observer, it is understandable that military interest in the image converter eventually faded.

The tactical military disadvantages of so-called active (search beam

equipped) thermal imaging systems provided impetus following World War II for extensive secret military infrared-research programs into the possibilities of developing passive (no search beam) systems around the extremely sensitive photon detector. During this period, military secrecy regulations completely prevented disclosure of the status of infrared-imaging technology. This secrecy only began to be lifted in the middle of the 1950s and from that time adequate thermal-imaging devices finally began to be available to civilian science and industry.

Theory of Thermography

Introduction

The subjects of infrared radiation and the related technique of thermography are still new to many who will use an infrared camera. In this section, the theory behind thermography will be given.

The Electromagnetic Spectrum

The electromagnetic spectrum (Figure 5) is divided arbitrarily into a number of wavelength regions, called bands, distinguished by the methods used to produce and detect the radiation. There is no fundamental difference between radiation in the different bands of the electromagnetic spectrum. They are all governed by the same laws and the only differences are those due to differences in wavelength.

Thermography makes use of the infrared spectral band. At the short-wavelength end of the spectrum the boundary lies at the limit of visual perception, in the deep red. At the long-wavelength end of the spectrum it merges with the microwave radio wavelengths in the millimeter range.

The infrared band is often further subdivided into four smaller bands, the boundaries of which are also arbitrarily

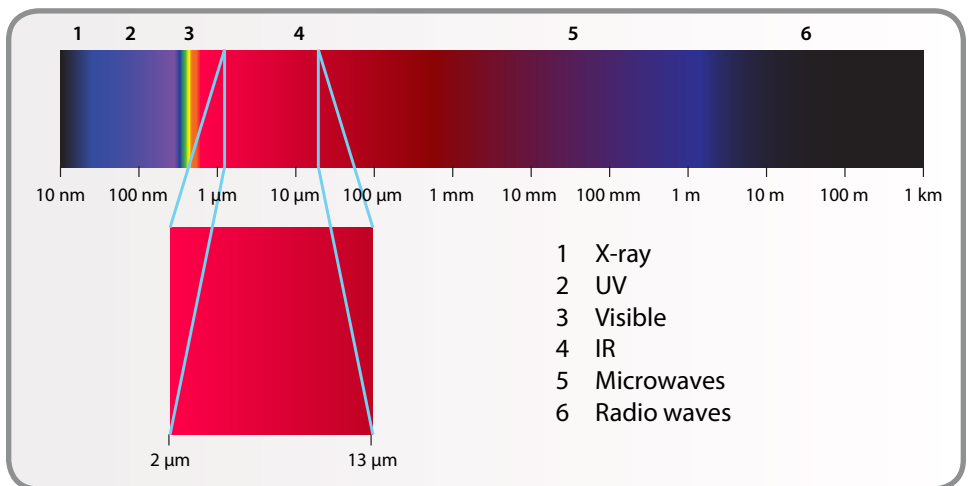

Figure 5. The electromagnetic spectrum

chosen. They include: the near infrared (0.75–3 μm), the middle infrared (3–6 μm), the far infrared (6–15 μm), and the extreme infrared (15–100 μm). Although the wavelengths are given in μm (micrometers), other units are often used to measure wavelength in this spectral region, for example, nanometer (nm) and Ångström (Å).

The relationships between the different wavelength measurements is:

$$10,000 \text{ \AA} = 1,000 \text{ nm} = 1 \mu\text{m}$$

Blackbody Radiation

A blackbody is defined as an object that absorbs all radiation that impinges on it at any wavelength. The apparent misnomer *black* relating to an object emitting radiation is explained by Kirchhoff's Law (after Gustav Robert Kirchhoff, shown in Figure 6), which states that a body capable of absorbing all radiation at any wavelength is equally capable in the emission of radiation.



Figure 6. Gustav Robert Kirchhoff (1824–1887)

The construction of a blackbody source is, in principle, very simple. The radiation characteristics of an aperture in an isothermal cavity made of an opaque absorbing material represents almost

exactly the properties of a blackbody. A practical application of the principle to the construction of a perfect absorber of radiation consists of a box that is light tight except for an aperture in one of the sides. Any radiation that then enters the hole is scattered and absorbed by repeated reflections, so only an infinitesimal fraction can possibly escape. The blackness which is obtained at the aperture is nearly equal to a blackbody and almost perfect for all wavelengths.

By providing such an isothermal cavity with a suitable heater, it becomes what is termed a cavity radiator. An isothermal cavity heated to a uniform temperature generates blackbody radiation, the characteristics of which are determined solely by the temperature of the cavity. Such cavity radiators are commonly used as sources of radiation in temperature reference standards in the laboratory for calibrating thermographic instruments, such as a FLIR Systems camera, for example.

If the temperature of blackbody radiation increases to more than 525°C (977°F), the source begins to be visible so that it no longer appears black to the eye. This is the incipient red heat temperature of the radiator, which then becomes orange or yellow as the temperature increases further. In fact, the definition of the so-called color temperature of an object is the temperature to which a blackbody would have to be heated to have the same appearance.

Now consider three expressions that describe the radiation emitted from a blackbody.

Planck's Law



Figure 7. Max Planck (1858–1947)

Max Planck (Figure 7) was able to describe the spectral distribution of the radiation from a blackbody by means of the following formula:

$$W_{\lambda_b} = \frac{2\pi hc^3}{\lambda^5(e^{hc/\lambda kT} - 1)} \times 10^{-6} \text{ [Watt/m}^2\mu\text{m]}$$

where:

W_{λ_b} Blackbody spectral radiant emittance at wavelength λ_b

c Velocity of light = 3×10^8 m/s

h Planck's constant = 6.6×10^{-34} Joule sec

k Boltzmann's constant = 1.4×10^{-23} Joule/K

T Absolute temperature (K) of a blackbody

λ Wavelength (μm)

The factor 10^{-6} is used since spectral emittance in the curves is expressed in Watt/m²m. If the factor is excluded, the dimension will be Watt/m² μm .

Planck's formula, when plotted graphically for various temperatures, produces a family of curves. Following

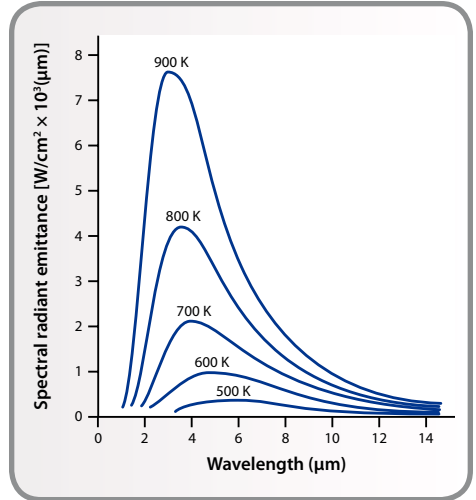

Figure 8. Blackbody spectral radiant emittance according to Planck's law, plotted for various absolute temperatures.

any particular Planck curve, the spectral emittance is zero at $\lambda = 0$, then increases rapidly to a maximum at a wavelength μ_{max} and after passing it approaches zero again at very long wavelengths. The higher the temperature, the shorter the wavelength at which maximum occurs. See Figure 8.

Wien's Displacement Law

By differentiating Planck's formula with respect to λ and finding the maximum, we have:

$$\lambda_{\text{max}} = \frac{2898}{T} \text{ } [\mu\text{m}]$$

This is Wien's formula (after Wilhelm Wien, shown in Figure 9), which expresses mathematically the common observation that colors vary from red to orange or yellow as the temperature of a thermal radiator increases (Figure 10). The wavelength of the color is the same as

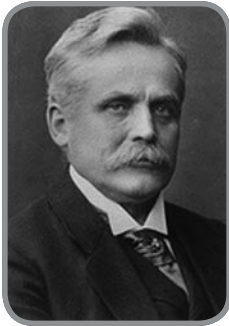

Figure 9. Wilhelm Wien (1864–1928)

the wavelength calculated for λ_{\max} . A good approximation of the value of μm for a given blackbody temperature is obtained by applying the rule-of-thumb $3,000/T \mu\text{m}$. Thus, a very hot star such as Sirius (11,000 K), emitting bluish-white

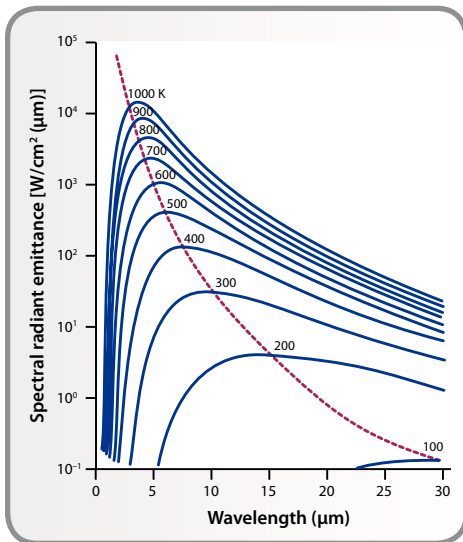

Figure 10. Planckian curves plotted on semi-log scales from 100 K to 1000 K. The dotted line represents the locus of maximum radiant emittance at each temperature as described by Wien's displacement law.

light, radiates with the peak of spectral radiant emittance occurring within the invisible ultraviolet spectrum at wavelength $0.27 \mu\text{m}$.

The sun (approx. 6,000 K) emits yellow light, peaking at about $0.5 \mu\text{m}$ in the middle of the visible light spectrum.

At room temperature (300 K) the peak of radiant emittance lies at $9.7 \mu\text{m}$ in the far infrared, while at the temperature of liquid nitrogen (77 K) the maximum of the almost insignificant amount of radiant emittance occurs at $38 \mu\text{m}$ in the extreme infrared wavelengths.

By integrating Planck's formula from $\lambda = 0$ to $\lambda = \infty$, we obtain the total radiant emittance (W_b) of a blackbody:

$$W_b = \sigma T^4 \text{ [Watt/m}^2\text{]}$$

This is the Stefan-Boltzmann formula (after Josef Stefan and Ludwig Boltzmann, shown in Figure 11), which states that the total emissive power of a blackbody is proportional to the fourth power of its absolute temperature. Graphically, W_b represents the area below the Planck curve for a particular temperature. It can show that the radiant emittance in the interval $\lambda = 0$ to λ_{\max} is only 25% of the total, which represents



Figure 11. Josef Stefan (1835–1893) and Ludwig Boltzmann (1844–1906)

approximately the amount of the sun's radiation that lies inside the visible light spectrum.

Using the Stefan-Boltzmann formula to calculate the power radiated by the human body, at a temperature of 300 K and an external surface area of approx. 2 m², we obtain 1 kW. This power loss could not be sustained if it were not for the compensating absorption of radiation from surrounding surfaces at room temperatures, which do not vary too drastically from the temperature of the body – or, of course, the addition of clothing.

Non-blackbody Emitters

So far, only blackbody radiators and blackbody radiation have been discussed. However, real objects almost never comply with these laws over an extended wavelength region – although they may approach the blackbody behavior in certain spectral intervals. For example, a certain type of white paint may appear perfectly white in the visible light spectrum, but becomes distinctly *gray* at about 2 μm, and beyond 3 μm it is almost *black*.

There are three processes that can prevent a real object from acting like a blackbody: a fraction of the incident radiation α may be absorbed, a fraction ρ may be reflected, and a fraction τ may be transmitted. Since all of these factors are more or less wavelength dependent, the subscript λ is used to imply the spectral dependence of their definitions. Thus:

- The spectral absorptance α_λ = the ratio of the spectral radiant power absorbed by an object to that incident upon it.

- The spectral reflectance ρ_λ = the ratio of the spectral radiant power reflected by an object to that incident upon it.
- The spectral transmittance τ_λ = the ratio of the spectral radiant power transmitted through an object to that incident upon it.

The sum of these three factors must always add up to the whole at any wavelength, so we have the relation:

$$\alpha_\lambda + \rho_\lambda + \tau_\lambda = 1$$

For opaque materials $\tau_\lambda = 0$ and the relation simplifies to:

$$\alpha_\lambda + \rho_\lambda = 1$$

Another factor, called the emissivity, is required to describe the fraction ϵ of the radiant emittance of a blackbody produced by an object at a specific temperature. Thus, we have the definition: spectral emissivity ϵ_λ = the ratio of the spectral radiant power from an object to that from a blackbody at the same temperature and wavelength.

Expressed mathematically, this can be written as the ratio of the spectral emittance of the object to that of a blackbody as follows:

$$\epsilon_\lambda = \frac{W_{\lambda o}}{W_{\lambda b}}$$

Generally speaking, there are three types of radiation sources, distinguished by the ways in which the spectral emittance of each varies with wavelength (Figures 12 and 13).

- A blackbody, for which $\epsilon_\lambda = \epsilon = 1$
- A graybody, for which $\epsilon_\lambda = \epsilon = \text{constant}$ less than 1
- A selective radiator, for which ϵ varies with wavelength

According to Kirchoff's law, for any material the spectral emissivity and spectral absorptance of a body are equal at any specified temperature and wavelength. That is:

$$\epsilon_{\lambda} = \alpha_{\lambda}$$

From this we obtain, for an opaque material (since $\alpha_{\lambda} + \rho_{\lambda} = 1$):

$$\epsilon_{\lambda} + \rho_{\lambda} = 1$$

For highly polished materials ϵ_{λ} approaches zero, so for a perfectly reflecting material (for example, a perfect mirror) we have:

$$\rho_{\lambda} = 1$$

For a graybody radiator, the Stefan-Boltzmann formula becomes:

$$W = \epsilon \sigma T^4 \text{ [Watt/m}^2\text{]}$$

This states that the total emissive power of a graybody is the same as a blackbody at the same temperature reduced in proportion to the value of ϵ from the graybody.

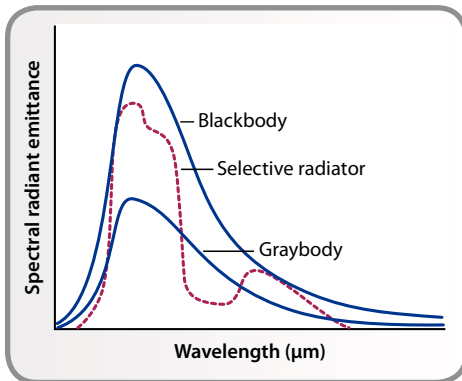

Figure 12. Spectral radiant emittance of three types of radiators.

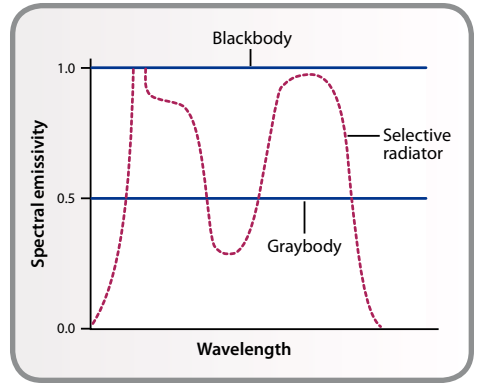

Figure 13. Spectral emissivity of three types of radiators.

Infrared Semi-transparent Materials

Consider a non-metallic, semi-transparent body in the form of a thick flat plate of plastic material. When the plate is heated, radiation generated within its volume must work its way toward the surfaces through the material in which it is partially absorbed. Moreover, when it arrives at the surface, some of it is reflected back into the interior. The back-reflected radiation is again partially absorbed, but some of it arrives at the other surface, through which most of it escapes, but part of it is reflected back again. Although the progressive reflections become weaker and weaker, they must all be added up when the total emittance of the plate is sought. When the resulting geometrical series is summed, the effective emissivity of a semi-transparent plate is obtained as:

$$\epsilon_{\lambda} = \frac{(1 - \rho_{\lambda})(1 - \tau_{\lambda})}{1 - \rho_{\lambda}\tau_{\lambda}}$$

When the plate becomes opaque this formula is reduced to the single formula:

$$\epsilon_{\lambda} = 1 - \rho_{\lambda}$$

This last relation is a particularly convenient one, because it is often easier to measure reflectance than to measure emissivity directly.

The Measurement Formula

As already mentioned, when viewing an object, the camera receives radiation not only from the object itself, it also collects radiation from the surroundings reflected via the object surface. Both these radiation contributions become attenuated to some extent by the atmosphere in the measurement path. To this comes a third radiation contribution from the atmosphere itself.

This description of the measurement situation, as illustrated in Figure 14, is so far a fairly true description of the real conditions. What has been neglected could for instance be sun light scattering in the atmosphere or stray radiation from intense radiation sources outside the field of view. Such disturbances are difficult to quantify. However, in most cases they are fortunately small enough to be

neglected. In case they are not negligible, the measurement configuration is likely to be such that the risk for disturbance is obvious, at least to a trained operator. It is then his responsibility to modify the measurement situation to avoid the disturbance (by changing the viewing direction, shielding off intense radiation sources, etc.).

Accepting the description above, we can use Figure 14 to derive a formula for the calculation of the object temperature from the calibrated camera output.

Assume that the received radiation power W from a blackbody source of temperature T_{source} on short distances generates a camera output signal U_{source} that is proportional to the power input (power linear camera). We can then write (Equation 1):

$$U_{\text{source}} = CW (T_{\text{source}})$$

or, with simplified notation:

$$U_{\text{source}} = CW_{\text{source}}$$

where C is a constant.

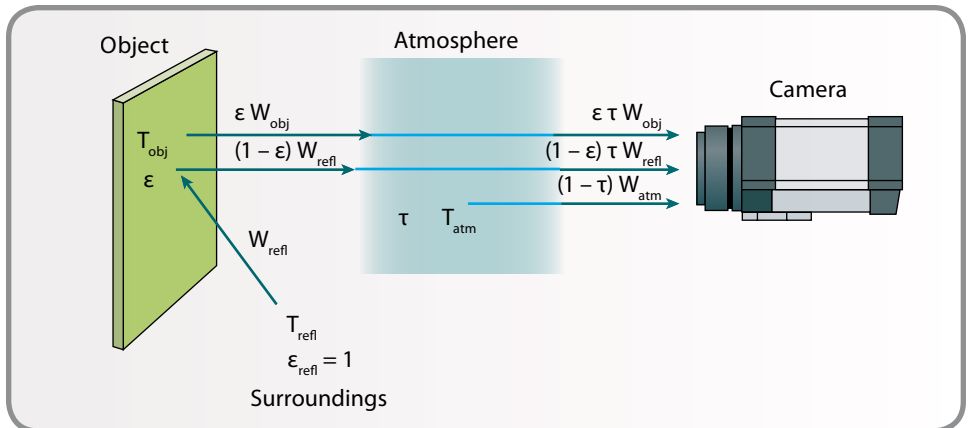

Figure 14. A schematic representation of the general thermographic measurement situation.

Should the source be a graybody with emittance ϵ , the received radiation would consequently be $\epsilon W_{\text{source}}$.

We are now ready to write the three collected radiation power terms:

1. *Emission from the object* = $\epsilon\tau W_{\text{obj}}$ where ϵ is the emittance of the object and τ is the transmittance of the atmosphere. The object temperature is T_{obj} .
2. *Reflected emission from ambient sources* = $(1 - \epsilon)\tau W_{\text{refl}}$, where $(1 - \epsilon)$ is the reflectance of the object. The ambient sources have the temperature T_{refl} .

It has here been assumed that the temperature T_{refl} is the same for all emitting surfaces within the half-sphere seen from a point on the object surface. This is of course sometimes a simplification of the true situation. It is, however, a necessary simplification in order to derive a workable formula, and T_{refl} can – at least theoretically – be given a value that represents an efficient temperature of a complex surrounding.

Note also that we have assumed that the emittance for the surroundings = 1. This is correct in accordance with Kirchhoff's law: All radiation impinging on the surrounding surfaces will eventually be absorbed by the same surfaces. Thus the emittance = 1. (Note, though, that the latest discussion requires the complete sphere around the object to be considered.)

3. *Emission from the atmosphere* = $(1 - \tau)\tau W_{\text{atm}}$, where $(1 - \tau)$ is the emittance of the atmosphere. The temperature of the atmosphere is T_{atm} .

The total received radiation power can now be written (Equation 2):

$$W_{\text{tot}} = \epsilon\tau W_{\text{obj}} + (1 - \epsilon)\tau W_{\text{refl}} + (1 - \tau)W_{\text{atm}}$$

We multiply each term by the constant C of Equation 1 and replace the CW products by the corresponding U according to the same equation, and get (Equation 3):

$$U_{\text{tot}} = \epsilon\tau U_{\text{obj}} + (1 - \epsilon)\tau U_{\text{refl}} + (1 - \tau)U_{\text{atm}}$$

Solve Equation 3 for U_{obj} (Equation 4):

$$U_{\text{obj}} = \frac{1}{\epsilon\tau} U_{\text{tot}} - \frac{1 - \epsilon}{\epsilon} U_{\text{refl}} - \frac{1 - \tau}{\epsilon\tau} U_{\text{atm}}$$

This is the general measurement formula used in all the FLIR Systems thermographic equipment. The voltages of the formula are given in Table 1.

Table 1. Voltages

U_{obj}	Calculated camera output voltage for a blackbody of temperature T_{obj} , which is a voltage that can be directly converted into true requested object temperature.
U_{tot}	Measured camera output voltage for the actual case.
U_{refl}	Theoretical camera output voltage for a blackbody of temperature T_{refl} according to the calibration.
U_{atm}	Theoretical camera output voltage for a blackbody of temperature T_{atm} according to the calibration.

The operator has to supply a number of parameter values for the calculation:

- object emittance ϵ
- relative humidity
- T_{atm}
- object distance (D_{obj})
- (effective) temperature of the object surroundings or the reflected ambient temperature T_{refl}
- the temperature of the atmosphere T_{atm}

This task can sometimes be a heavy burden for the operator since there are normally no easy ways to find accurate values of emittance and atmospheric transmittance for the actual case. The two temperatures are normally less of a problem provided the surroundings do not contain large and intense radiation sources.

A natural question in this connection is: How important is it to know the right values of these parameters? It could be of interest to get a feeling for this problem by looking into some different measurement cases and compare the relative magnitudes of the three radiation terms. This will give indications about when it is important to use correct values for which parameters.

Figures 15 and 16 illustrate the relative magnitudes of the three radiation contributions for three different object temperatures, two emittances, and two spectral ranges: SW and LW. Remaining parameters have the following fixed values:

- $\tau = 0.88$
- $T_{\text{refl}} = +20^{\circ}\text{C} (+68^{\circ}\text{F})$
- $T_{\text{atm}} = +20^{\circ}\text{C} (+68^{\circ}\text{F})$

It is obvious that measurement of low object temperatures is more critical than measuring high temperatures since the “disturbing” radiation sources are relatively much stronger in the first case. Should the object emittance be low, the situation would be more difficult.

We have finally to answer a question about the importance of being allowed to use the calibration curve above the highest calibration point, what we call extrapolation. Imagine that we in a

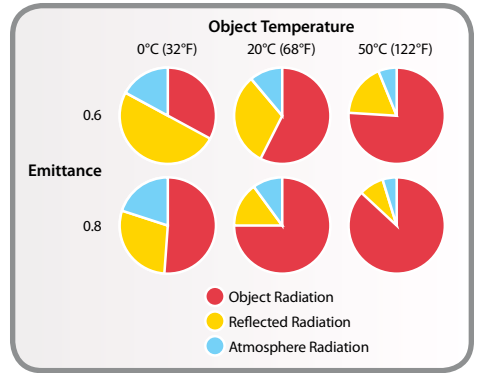

Figure 15. Relative magnitudes of radiation sources under varying measurement conditions (SW camera). Fixed parameters: $\tau = 0.88$; $T_{\text{refl}} = 20^{\circ}\text{C} (+68^{\circ}\text{F})$; $T_{\text{atm}} = 20^{\circ}\text{C} (+68^{\circ}\text{F})$.

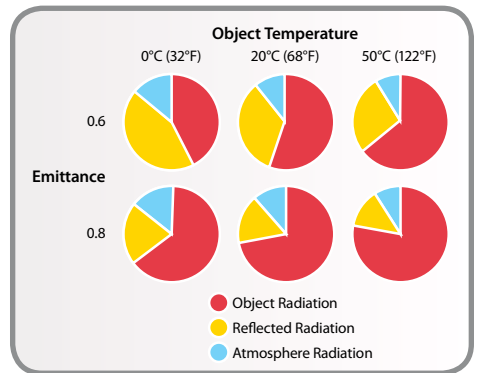

Figure 16. Relative magnitudes of radiation sources under varying measurement conditions (LW camera). Fixed parameters: $\tau = 0.88$; $T_{\text{refl}} = 20^{\circ}\text{C} (+68^{\circ}\text{F})$; $T_{\text{atm}} = 20^{\circ}\text{C} (+68^{\circ}\text{F})$.

certain case measure $U_{\text{tot}} = 4.5$ volts. The highest calibration point for the camera was in the order of 4.1 volts, a value unknown to the operator. Thus, even if the object happened to be a blackbody ($U_{\text{obj}} = U_{\text{tot}}$), we are actually performing extrapolation of the calibration curve when converting 4.5 volts into temperature.

Let us now assume that the object is not black, it has an emittance of 0.75 and the transmittance is 0.92. We also assume that the two second terms of Equation 4 amount to 0.5 volts together. Computation of U_{obj} by means of Equation 4 then results in $U_{obj} = 4.5 / 0.75 / 0.92 - 0.5 = 6.0$. This is a rather extreme extrapolation, particularly when considering that the video amplifier might limit the output to 5 volts. Note, though, that the application

of the calibration curve is a theoretical procedure where no electronic or other limitations exist. We trust that if there had been no signal limitations in the camera, and if it had been calibrated far beyond 5 volts, the resulting curve would have been very much the same as our real curve extrapolated beyond 4.1 volts, provided the calibration algorithm is based on radiation physics, like the FLIR Systems algorithm. Of course there must be a limit to such extrapolations.

Command Syntax Examples for A320 Resource Socket Services

Physical Interface

From the camera, there is only one physical interface for data transfer, Ethernet. Analog video also exists, but is not considered a data transfer interface.

Low Level Protocols

For Ethernet, only TCP/IP is supported. The camera should seamlessly work on any LAN, provided that a proper IP address, netmask, and possibly gateway is set in the camera.

No FLIR specific device drivers are required, so any type of computer and operating systems supporting TCP/IP should work.

Functionality

The two main ways of controlling the camera are through the command control interface and through the resource control interface. Image streaming, file transfer, and other functionality is provided through the IP services interface.

Command Control

Commands can be given to the "commandshell" in the camera. Some commands are "standardcommands" like "dir" and "cd" that operate directly on the camera themselves. Others rely on camera resources (see below), for example the "level" command.

It is possible to run independent instances of the command shell with the

"telnet" service on established TCP/IP connections.

Resource Control

Most, but not all, software functionality is exposed through software resources. Those that are familiar with the Microsoft Windows registry will recognize this concept. However, in the camera a resource node can also represent a software function that, upon read or write, actively interacts with the camera software.

The following lists some introductory details about software resources and resource nodes.

- Resources are organized in a hierarchy (like in a tree).
- Resource nodes can be data holders (of for example, calibration data).
- Resource nodes can be connected to hardware (for example, to internal temperature sensor values).
- Resource nodes can be connected to software (for example, to spotmeter values)
- Resource nodes have a type (double, int32, ascii, etc.) and certain attributes (readonly, read/write).
- Resources can be reached through commands like "rls" and "rset," and through the IP FLIR Resource socket service.

IP Services

It is possible to access the system independent of physical interface using TCP/IP with exposed services such as telnet, ftp, http, CIFS, FLIR resource socket, and FLIR RTP. More than one service and possibly more than one

instance of the service can be run simultaneously.

telnet

Command control, mainly for manual typing. Typical clients are the standard telnet command on a PC or teraterm.

FTP

File transfer to/from the camera using FTP client software on a PC. Typical clients are the standard FTP command on a PC or WS_FTP.

http

Web server. Typical clients are Microsoft Internet Explorer and Firefox.

CIFS

PC network file access service. This service makes it possible to map a drive on the PC to the camera file system. The intended client software is built into all relevant Windows versions. By default, only the image folders are accessible in this way. To access the whole flash file system, mount the xxx.xxx.xxx.xxx/roots drive.

FLIR Resource Socket

It is possible to directly read and write nodes of the software resource tree from a PC. Standard sockets are used, but there are no standard client programs available.

Image Streaming

Set-up

The available streams are described and presented using SDP (Session Description Language, RFC 2327). The SDP content is accessed using RTSP (Real Time Streaming Protocol, RFC 2326).

The RTSP/DESCRIBE command lists the available streams.

Table 1

MPEG4	Compressed video in three sizes (640x480, 320x240, 160x128)
FCAM	FLIR usage only.
Raw	IR-signal or temperature linear IR-image (two types) in two sizes (320x240, 160x120). The pixels are transferred in network byte order (big endian).

The RTSP/SETUP command establishes an RTP-based transport session using one of the formats.

The RTSP/GET_PARAMETER command gets the current framerate and format.

The RTSP/SET_PARAMETER command sets the current framerate and format.

The RTSP/PLAY and RTSP/PAUSE commands control the image stream.

The RTSP/TEARDOWN command closes the transport session.

MPEG4

The MPEG4 streams use RTP/UDP/IP for transport (RTP = Real time Transport Protocol, RFC 1889). The MPEG bit stream is packetized according to RFC 3016.

On the receiver side, FLIR supplies a DirectShow component (Win32, PC platform) which is able to receive the MPEG4 bit stream. The component is able to receive the MPEG4 bit stream according to RFC 3016. The bit stream is reassembled and forwarded as video samples of FOURCC type MP4V. Several MPEG4 decoders can be used, for example from 3ivx (\$7 per license) or a free decoder (ffdshow). The DirectShow component can be used by any application that wishes to display the MPEG4 video stream.

IR Streams

The raw IR streams use RTP/UDP/IP for transport. The transport format is according to RFC 4175 (RTP Payload Format for Uncompressed Video).

The raw image frame rates are up to about 7.8 Hz.

These raw formats are provided:

Table 2.

0	16-bit uncompressed IR image linear in signal
1	16-bit uncompressed IR image linear in temperature, resolution 0.1 K (range 0–6553 K)
2	16-bit uncompressed IR image linear in temperature, resolution 0.01 K (range 0–655 K)

On the client side, FLIR supplies a DirectShow component (Win32, PC platform) which is able to setup and receive the IR streams. The IR stream is reassembled and forwarded as samples of FOURCC type Y160 (this FOURCC type is only preliminary at this stage). The DirectShow component can be used by any application that wishes to display the IR stream or want to grab samples from the stream.

DHCP

The camera supports the client part of the Dynamic Host Configuration Protocol (DHCP).

Remote Detection

Multicast DNS (Bonjour)

To query Bonjour for local FLIR IR cameras, use:

- Service name: flir-ircam
- Protocol type: _tcp
- Domain: local

Table 3: TXT records

Name	Value	Explanation
Model	S	
ID	A320	Camera ID
GID	Gen_A	Generic ID
SI	FFF_RTSP	Streaming Interface
SIV	1.0.0	Streaming interface version
CI	RTREE	Command interface
CIV	1.0.0	Command interface version

For more information, see www.dns-sd.org.

For complete information, see FLIR's A320 ICD manual.



	Photon	A320	A325
Sensor Type	μbolometer	μbolometer	μbolometer
Pixel Resolution	324×256	320×240	320×240
Pixel Pitch	38μm	25μm	25μm
Spectral Ranges	7.5μm – 13.5μm	7.5μm – 13.0μm	7.5μm – 13.0μm
Dynamic Range	14-bit	14-bit, Signal + Temp Linear	14-bit, GiGE Vision + Gen<i>Cam
Internal Temperature Calibration		•	•
Ambient Drift Compensation	•	•	•
Temperature Calibration	Imager Only	•	•
Full Frame Rate	30 fps	30 fps	60 fps
Digital Data Output	GiGE (optional) or Serial	Ethernet	GiGE
Analog Video	RS-170	RS-170	
Command and Control	RS-232 or GiGE (optional)	Ethernet	GiGE
On-Board Analytics		•	
Motorized Focus		•	•
Auto Focus		•	•
Digital I/O		•	•
Triggering Options	•	•	•
Remote Camera Control	Proprietary	Web, TCP/IP (Open Protocol)	GeniCam
PoE Compatible		•	
Messaging		FTP, SMTP	
SDK Support	•	•	•
LabVIEW Compatibility	•	•	•
Aperture	f/1.3, f/1.4, f/1.4, f/1.7 lens dependent	f/1.3	f/1.3
Filtering Options			
Available Optics	14.25mm 19mm 35mm 50mm	18mm 30mm 10mm	18mm 30mm 10mm



Published by FLIR Systems Incorporated
www.goinfrared.com