

The theoretical extension force is calculated as follows: [Filling Pressure] x [Cross Section of the Piston Rod].
 By changing these two factors, it is possible for Bansbach® to supply gas springs with any requested extension force.
 Our standard specifications are available from 10N to 5000N. The extension force is always mentioned with the specifications and is recognized as the value F1 measured at 20°C ± 2°C with the piston rod showing downwards.

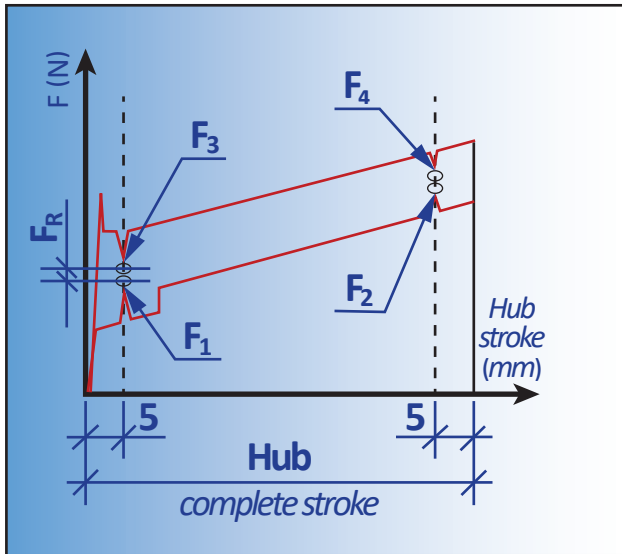

FORCE DIAGRAM

- F1** = extension force with extended piston rod
- F2** = extension force with compressed piston rod
- F3** = pull-in force with extended piston rod
- F4** = pull-in force with compressed piston rod
- FR** = friction force

These values can be influenced by factors such as gas volume and oil quality. One of the special characteristics of Bansbach® gas springs is the low friction force. Through different combinations of nozzle orifices and oil quality, it is possible to control the push-out and push-in speed as required.

CALCULATION PRINCIPLE F1

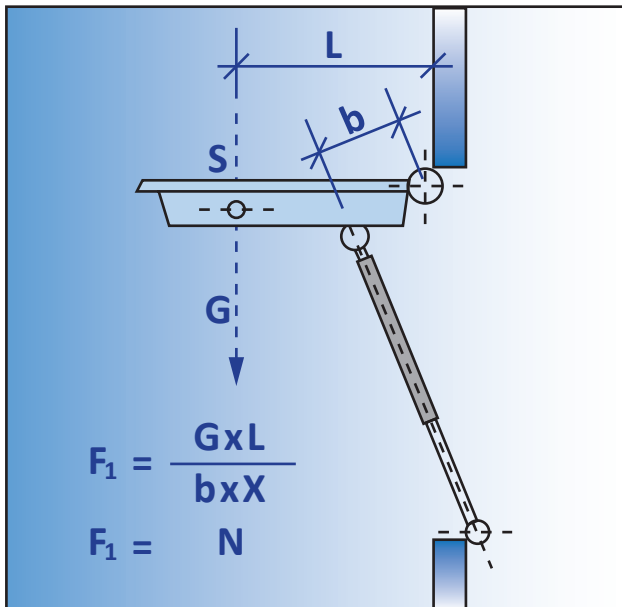

EXTENDED FORCE

- S** = Center of gravity
- G** = Weight of the flap in N (ca. Kp x 10)
- b** = Power arm
(corresponds to about 85% of the required stroke)
- X** = Number of the springs
(in general 2 pieces, one for each side of the flap)

Our general extension force tolerance is +40N/-20N or ± 5-7%
 Physically, the actual force of a gas spring depends on the temperature. For each 10°C, the force changes by approx 3.3%.
 Size and extension force can be made according to your requirements. We would be pleased to help you design a gas spring for your application.